

CATALOGUE

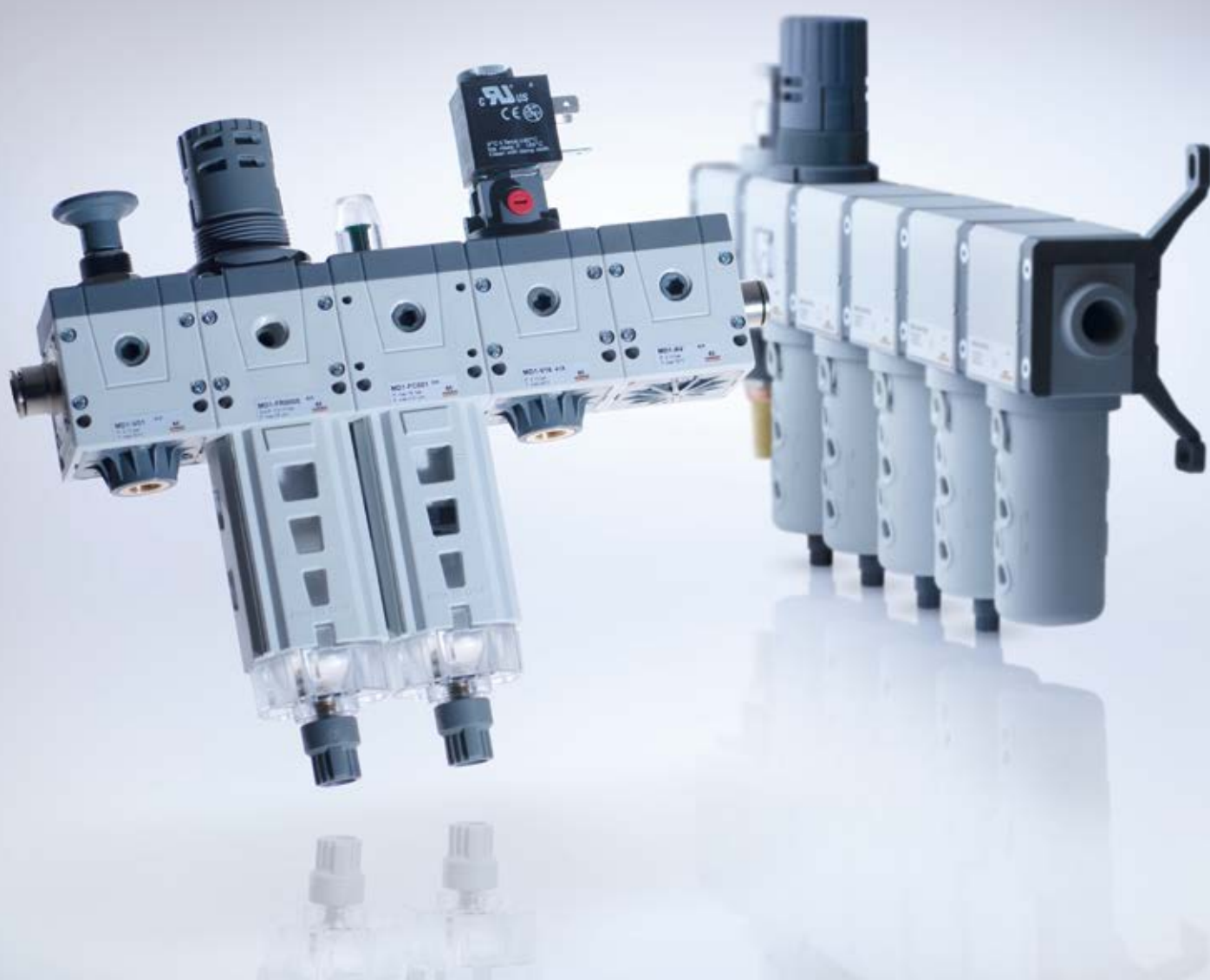

AIR TREATMENT



WELCOME TO CAMOZZI AUTOMATION

Camozzi Automation is a global leader in the design and production of motion and fluid control components, systems and technologies for Industrial automation, Transportation and Life science industries.



Contacts

Camozzi Automation S.p.A.
Società Unipersonale
Via Eritrea, 20/I
25126 Brescia
Italy
Tel. +39 030 37921
www.camozzi.com

Customer Service
Tel. +39 030 3792790
service@camozzi.com

Export Department
Tel. +39 030 3792253
sales@camozzi.com

Our catalogues

1 Pneumatic actuation



- 1 International standard cylinders
- 2 Compact cylinders
- 3 Stainless steel cylinders
- 4 Guided cylinders
- 5 Cylinders not according standards
- 6 Rotary cylinders
- 7 Rodless cylinders
- 8 Proximity switches
- 9 Hydrochecks, Rod lock, Shock absorbers

2 Electric actuation



- 1 Electromechanical cylinders
- 2 Electromechanical axes
- 3 Drives
- 4 Motors and gearboxes

3 Handling



- 1 Grippers

4 Vacuum components



- 1 Suction pads
- 2 Ejectors
- 3 Vacuum accessories
- 4 Vacuum filters

5 Valves and solenoid valves



- 1 Direct and indirect acting 2/2, 3/2 solenoid valves
- 2 Solenoid, pneumatic and manifold valves
- 3 Mechanical and manual valves
- 4 Logic valves
- 5 Automatic valves
- 6 Flow control valves
- 7 Silencers

6 Fieldbus and multipole systems



- 1 Valve islands
- 2 Multi-serial modules

7 Proportional technology



- 1 Proportional valves
- 2 Proportional regulators

8 Air treatment



- 1 Series MX Modular FRL Units
- 2 Series MC Modular FRL Units
- 3 Series MD Modular FRL Units
- 4 Series N FRL Units
- 5 Pressure regulators
- 6 Pressure switches and vacuum switches
- 7 Accessories for air treatment

9 Fittings, connectors, tubing and accessories















- 1 Super-rapid fittings
- 2 Rapid fittings
- 3 Universal fittings
- 4 Fittings accessories
- 5 Quick-release couplings
- 6 Tubing, spirals and accessories
- 7 Fittings and accessories for applications of medical gases
- 8 Mini ball valves

General index











1 Series MX Modular FRL Units

		Section	Page
	Series MX Filters	1.05	1
	Series MX Coalescing filters	1.10	5
	Series MX Activated carbon filters	1.15	9
	Series MX Pressure regulators	1.20	13
	Series MX Pneumatic pilot operated pressure regulators	1.21	18
	Series MX Lubricators	1.25	22
	Series MX Filter-regulators	1.30	25
	Series MX Lockable isolation 3/2-way valves	1.35	29
	Series MX SAFEMAX 3/2-way quick exhaust safety valves	1.XX	35
	Series MX SAFEMAX 3/2-way quick exhaust safety valves with soft start	1.XX	40
	Series MX Soft start valves	1.40	45
	Series MX Take-off blocks	1.45	49
	Series MX Accessories	1.49	52
	Series MX Assembled FRL	1.50	57





2 Series MC Modular FRL Units

		Section	Page
	Series MC Filters	2.05	68
	Series MC Coalescing filters	2.10	71
	Series MC Activated carbon filters	2.12	74
	Series MC Pressure regulators	2.15	77
	Series MC Lubricators	2.20	81
	Series MC Filter-regulators	2.25	84
	Series MC Lockable isolation 3/2-way valves	2.30	87
	Series MC Soft start valves	2.35	91
	Series MC Take-off blocks	2.40	94
	Series MC Accessories	2.44	96
	Series MC Assembled FRL	2.45	101
	Series MC Manifold pressure regulators	2.50	110







3 Series MD Modular FRL Units

	Section	Page
	Series MD Filters new automatic drain	3.05 114
	Series MD Coalescing filters	3.10 119
	Series MD Activated carbon filters	3.15 124
	Series MD Pressure regulators	3.20 128
	Series MD Lubricators	3.25 134
	Series MD Pressure filter-regulators new automatic drain	3.30 138
	Series MD Lockable isolation 3/2-way valves	3.35 142
	Series MD Soft start valves	3.40 148
	Series MD Take-off blocks	3.45 151
	Series MD Accessories	3.49 155
	Series MD Assembled FRL	3.50 159





4 Series N FRL Units

	Section	Page
	Series N Filters, coalescing filters and activated carbon filters	4.05 162
	Series N Pressure regulators	4.10 165
	Series N Lubricators	4.15 168
	Series N Filter-regulators	4.20 171
	Series N Accessories	4.25 174



5 Pressure regulators

	Section	Page
	Series CLR Micro pressure regulators	5.03 177
	Series TC Pressure microregulators	5.04 181
	Series M Pressure microregulators	5.05 186
	Series T Pressure microregulators	5.10 189
	Series M, T Accessories	5.12 191
	Series PR Precision regulators with manual override	5.15 193

6 Pressure switches and vacuum switches

	Section	Page
	Series PM, TRP, 2950 Pressure switches, Transducers, Pressure indicators	6.05 200
	New Series SWMN, SWMS Compact electronic pressure switches/vacuum switches	6.10 203
	Series SWDN Electronic vacuum/pressure switches	6.22 208
	Series SWCN Electronic vacuum/pressure switches	6.27 212

7 Air treatment accessories

	Section	Page
	Pressure gauges	7.05 218
	Series PG Digital pressure gauges	7.06 221
	Condensate drains filtering elements	7.10 225

Series MX filters

MX2 ports: G3/8, G1/2, G3/4 - MX3 ports: G3/4, G1
Modular
Bowl with technopolymer cover and bayonet-type mounting



- » Removal of impurities and condensate
- » High flow with minimum pressure decreases
- » Quality of delivered air according to ISO 8573-1:2010, Classes 7.8.4 and 6.8.4
- » Manual, automatic or depressuring drain
- » Polymer bowl locking system reducing the risk of accidents
- » Visual blockage indicator

The Series MX air treatment components are characterized by a modern, linear and compact design, offering high performances. The perfect integration between metal alloys and technopolymers has allowed the realization of a reliable product, light and strong at the same time. Thanks to a new concept of modularity, moreover, the mounting of components has become easier.

The Series MX has been realized to offer a multi-sector solution that guarantees saving in terms of installation time, space and costs.

A special configurator, available on Camozzi website at <http://catalogue.camozzi.com> (Configurators section), allows the customer to choose the most suitable solution for his application, selecting single components or by configuring assembled FRLs.

GENERAL DATA

Construction	modular, compact with filtering element in HDPE
Materials	see TABLE OF MATERIALS on the following page
Ports	MX2: G3/8 - G1/2 - G3/4 MX3: G3/4 - G1
Condensate capacity	MX2: 55 cm ³ MX3: 85 cm ³
Mounting	vertical in-line wall-mounting (by means of clamps)
Operating temperature	-5°C ÷ 50°C up to 16 bar (with the dew point of the fluid lower than 2°C at the min. working temperature) -5°C ÷ 60°C up to 10 bar (with the dew point of the fluid lower than 2°C at the min. working temperature)
Quality of delivered air according to ISO 8573-1:2010	Class 6.8.4 with 5 µm filtering element Class 7.8.4 with 25 µm filtering element
Operating pressure	0.3 ÷ 16 bar (with automatic drain 1.5 ÷ 12 bar)
Nominal flow	see FLOW DIAGRAMS on the following pages
Fluid	compressed air
Draining of condensate	semiautomatic-manual (standard), automatic, depressuring drain protected, direct exhaust G1/8

CODING EXAMPLE

MX	2	-	1/2	-	F	0	0	1	-	LH
-----------	----------	----------	------------	----------	----------	----------	----------	----------	----------	-----------

MX	SERIES
2	SIZE: 2 = G3/8 - G1/2 - G3/4 3 = G3/4 - G1
1/2	PORT: 3/8 = G3/8 1/2 = G1/2 3/4 = G3/4 1 = G1
F	FILTER
0	FILTERING ELEMENT: 0 = 25 µm (standard) 1 = 5 µm
0	DRAINING OF CONDENSATE (further details in the dedicated section): 0 = semiautomatic-manual drain (standard - only for polymer bowl) 3 = automatic drain 5 = depressuring drain, protected (only for polymer bowl) 8 = without drain, with port G1/8
1	VISUAL BLOCKAGE INDICATOR: = not present 1 = present
LH	FLOW DIRECTION: = from left to right (standard) LH = from right to left

For the assembly of a single component with fixing flanges or wall-mounting, see the section "FRL Series MX Assembled"

Filters Series MX - materials

A = Filter

B = Filter with visual blockage indicator

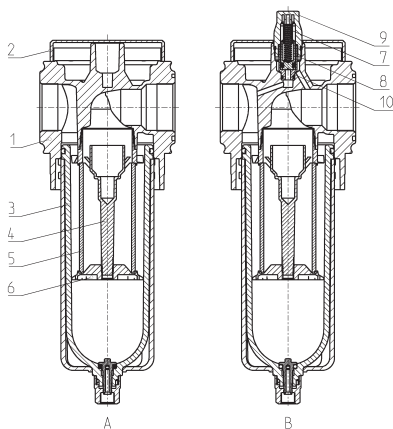

PARTS	MATERIALS
1 = Body	Aluminium
2 = Covering	Polyacetal
3 = Bowl / bowl cover	Polycarbonate/Polyamide
4 = Valve-guide	Polyacetal
5 = Filtering element	Polyethylene
6 = Separation deflector	Polyacetal
7 = Upper spring	Stainless steel
8 = Piston	Anodized aluminium
9 = Visual blockage indicator	Polycarbonate
10 = Indicator body	Brass
Seals	NBR

MX2 FILTERS FLOW DIAGRAMS

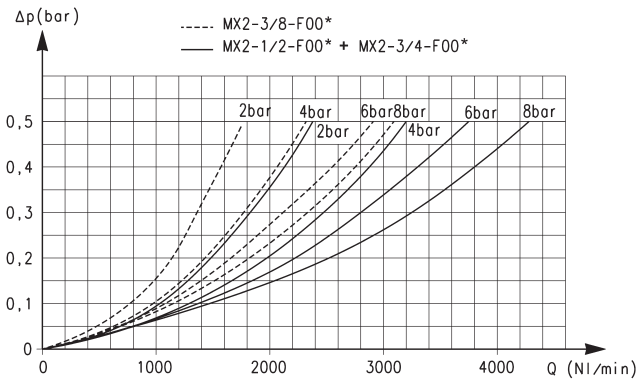

* Reference diagram for models with filtering element = 25 µm

Δp = Pressure drop (bar)
Q = Flow (NI/min)

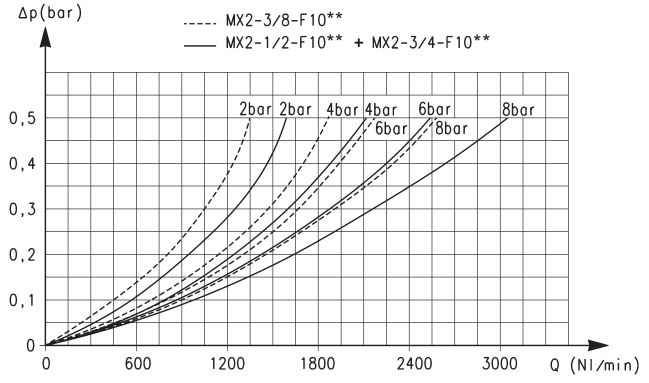

** Reference diagram for models with filtering element = 5 µm

Δp = Pressure drop (bar)
Q = Flow (NI/min)

MX3 FILTERS FLOW DIAGRAMS

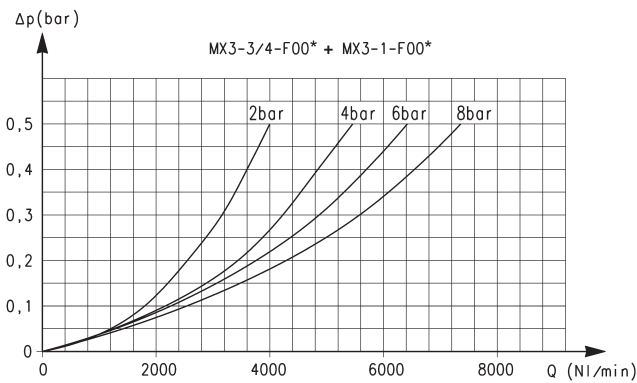

* Reference diagram for models with filtering element = 25 µm

Δp = Pressure drop (bar)
Q = Flow (NI/min)

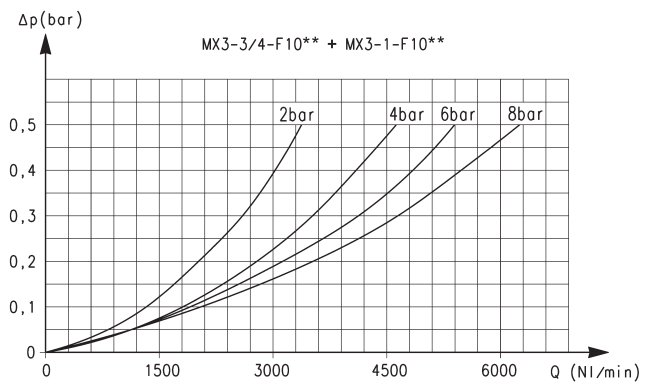

** Reference diagram for models with filtering element = 5 µm

Δp = Pressure drop (bar)
Q = Flow (NI/min)

Filters Series MX - dimensions

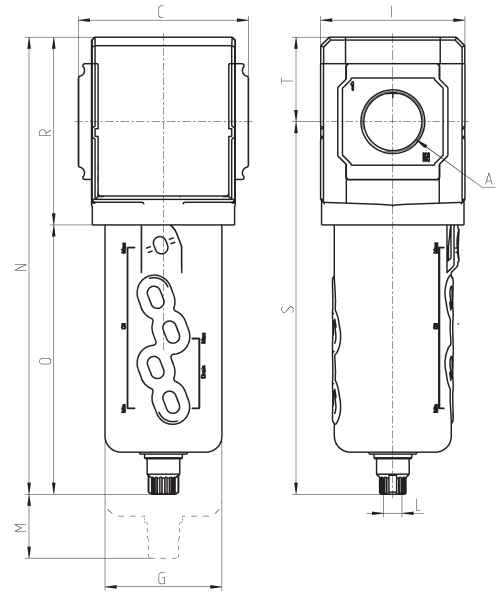

Mod.	A	C	G	I	L	M	N	O	R	S	T	Weight (Kg)
MX2-3/8-F00	G3/8	70	55.3	68	G1/8	57.5	212	127	85	174.5	37.5	0.5
MX2-1/2-F00	G1/2	70	55.3	68	G1/8	57.5	212	127	85	174.5	37.5	0.5
MX2-3/4-F00	G3/4	70	55.3	68	G1/8	57.5	212	127	85	174.5	37.5	0.5
MX3-3/4-F00	G3/4	89.5	61.5	76	G1/8	75	241	142	99	196.5	44.5	0.8
MX3-1-F00	G1	89.5	61.5	76	G1/8	75	241	142	99	196.5	44.5	0.8

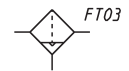
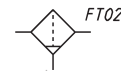

FT01 = filter with direct G1/8 exhaust

FT02 = filter with semi-automatic manual drain

FT03 = filter with automatic/ depressuring drain

Filters Series MX - dimensions

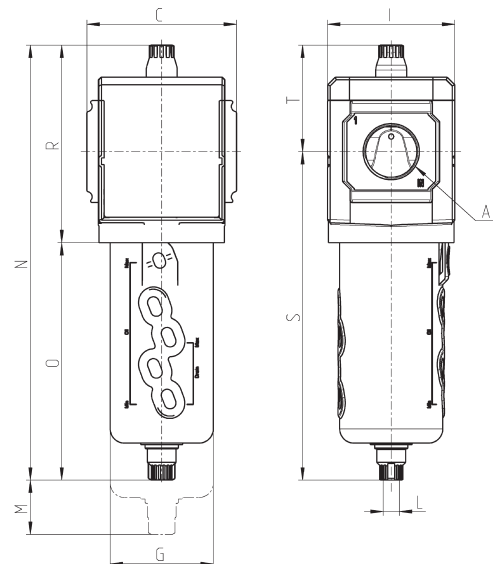

Mod.	A	C	G	I	L	M	N	O	R	S	T	Weight (Kg)
MX2-3/8-F001	G3/8	70	55.3	68	G1/8	57.5	231	127	104	174.5	56.5	0.5
MX2-1/2-F001	G1/2	70	55.3	68	G1/8	57.5	231	127	104	174.5	56.5	0.5
MX2-3/4-F001	G3/4	70	55.3	68	G1/8	57.5	231	127	104	174.5	56.5	0.5
MX3-3/4-F001	G3/4	89.5	61.5	76	G1/8	75	260	142	118	196.5	63.5	0.8
MX3-1-F001	G1	89.5	61.5	76	G1/8	75	260	142	118	196.5	63.5	0.8



FT05 = filter with direct G1/8 exhaust and visual blockage indicator

FT06 = filter with semi-automatic manual drain and visual blockage indicator

FT07 = filter with automatic/ depressuring drain and visual blockage indicator

Series MX coalescing filters

MX2 ports: G3/8, G1/2, G3/4 - MX3 ports: G3/4, G1
Modular

Bowl with technopolymer cover and bayonet-type mounting



- » High performance and compressed air quality (according to ISO 8573-1)
- » Quality of delivered air according to ISO 8573-1:2010, Classes 1.8.1 and 2.8.2
- » Manual, automatic or depressing drain
- » Polymer bowl locking system
- » Visual blockage indicator

The Series MX air treatment components are characterized by a modern, linear and compact design, offering high performances. The perfect integration between metal alloys and technopolymers has allowed the realization of a reliable product, light and strong at the same time. Thanks to a new concept of modularity, moreover, the mounting of components has become easier.

The Series MX has been realized to offer a multi-sector solution that guarantees saving in terms of installation time, space and costs.

A special configurator, available on Camozzi website at <http://catalogue.camozzi.com> (sec. Configurators), allows the customer to choose the most suitable solution for his application, selecting single components or by configuring assembled FRLs.

GENERAL DATA

Construction	modular, compact
Materials	see TABLE OF MATERIALS on the following page
Ports	MX2: G3/8, G1/2, G3/4 - MX3: G3/4, G1
Condensate capacity	MX2: 55 cm ³ - MX3: 85 cm ³
Mounting	vertical in-line or wall-mounting (by means of clamps)
Operating temperature	-5°C ÷ 50°C up to 16 bar (with the dew point of the fluid lower than 2°C at the min. working temp.) -5°C ÷ 60°C up to 10 bar (with the dew point of the fluid lower than 2°C at the min. working temp.)
Draining of condensate	manual-semi automatic (standard), automatic, depressurization protected, direct G1/8 exhaust
Operating pressure	0.3 ÷ 16 bar (with automatic drain 1.5 ÷ 12 bar)
Nominal flow	see FLOW DIAGRAMS on the following pages
Quality of delivered air according to ISO 8573-1:2010	Class 2.8.2 with 1 µm filtering element; Class 1.8.1 with 0.01 µm filtering element
Residual oil content with inlet at 3 mg/m ³	< 0.01mg/m ³ < 0.1mg/m ³
Oil retain efficiency	99.80% 97%
Particles retain efficiency	99.99999% 99.999%
Fluid	compressed air
Pre-filtering with filtering element of 1µm	it is recommended to use a filter of 5µm
Pre-filtering with filtering element of 0.01µm	it is recommended to use a filter of 1µm

CODING EXAMPLE

MX	2	-	1/2	-	FC	0	0	1	-	LH
-----------	----------	----------	------------	----------	-----------	----------	----------	----------	----------	-----------

MX	SERIES
2	SIZE: 2 = G3/8 - G1/2 - G3/4 3 = G3/4 - G1
1/2	PORTS: 3/8 = G3/8 1/2 = G1/2 3/4 = G3/4 1 = G1
FC	COALESCING FILTER
0	FILTERING ELEMENT: 0 = 0,01 µm (standard) 1 = 1 µm
0	DRAINING OF CONDENSATE (further details in the dedicated section): 0 = semiautomatic-manual drain (standard - only for polymer bowl) 3 = automatic drain 5 = depressuring drain, protected (only for polymer bowl) 8 = without drain, with port G1/8
1	VISUAL BLOCKAGE INDICATOR: = not present 1 = present
LH	FLOW DIRECTION: = from left to right (standard) LH = from right to left

For the assembly of a single component with fixing flanges or wall-mounting, see the section "FRL Series MX Assembled"

Coalescing filters Series MX - materials

A = Filter

B = Filter with visual blockage indicator

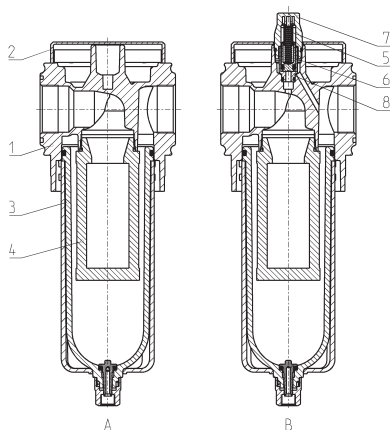

PARTS	MATERIALS
1 = Body	Aluminium
2 = Covering	Polyacetal
3 = Bowl / bowl cover	Polycarbonate/Polyamide
4 = Filtering element	Borosilicate
5 = Upper spring	Stainless steel
6 = Piston	Anodized aluminium
7 = Visual blockage indicator	Polycarbonate
8 = Indicator body	Brass
Seals	NBR

MX2 COALESCING FILTERS FLOW DIAGRAMS

SERIES MX COALESCING FILTERS

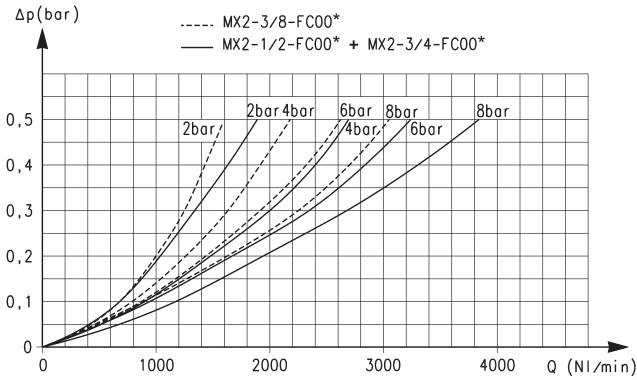

* Reference diagram for models with filtering element = 0.01 µm

Δp = Pressure drop (bar)
Q = Flow (NL/min)

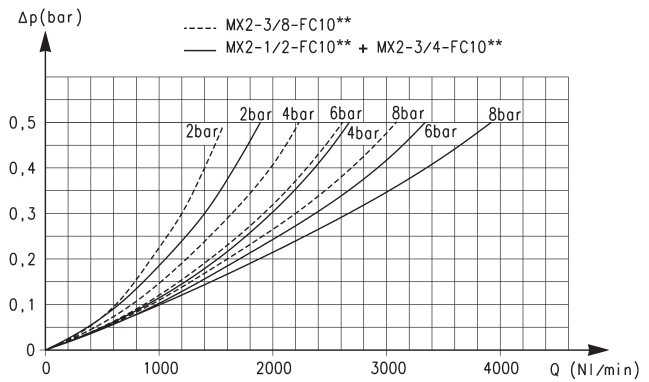

** Reference diagram for models with filtering element = 1 µm

Δp = Pressure drop (bar)
Q = Flow (NL/min)

MX3 COALESCING FILTERS FLOW DIAGRAMS

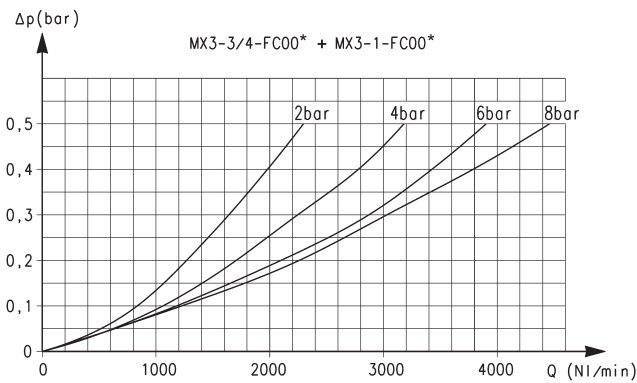

* Reference diagram for models with filtering element = 0.01 µm

Δp = Pressure drop (bar)
Q = Flow (NL/min)

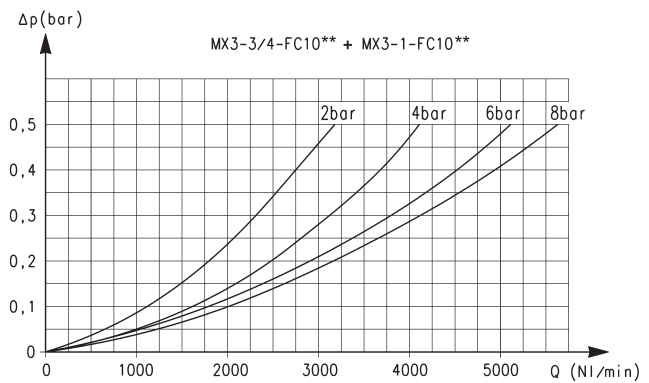

** Reference diagram for models with filtering element = 1 µm

Δp = Pressure drop (bar)
Q = Flow (NL/min)

Coalescing filters Series MX - dimensions

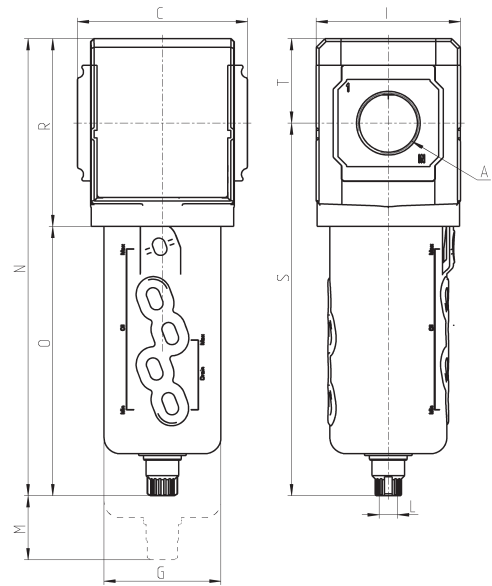

Mod.	A	C	G	I	L	M	N	O	R	S	T	Weight (Kg)
MX2-3/8-FC00	G3/8	70	55.3	68	G1/8	52	212	127	85	174.5	37.5	0.5
MX2-1/2-FC00	G1/2	70	55.3	68	G1/8	52	212	127	85	174.5	37.5	0.5
MX2-3/4-FC00	G3/4	70	55.3	68	G1/8	52	212	127	85	174.5	37.5	0.5
MX3-3/4-FC00	G3/4	89.5	61.5	76	G1/8	75	241	142	99	196.5	44.5	0.8
MX3-1-FC00	G1	89.5	61.5	76	G1/8	75	241	142	99	196.5	44.5	0.8

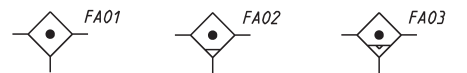

FA01 = coalescing filter without drain with port G1/8
 FA02 = coalescing filter with semi-automatic manual drain
 FA03 = coalescing filter with automatic or depressuring drain

Coalescing filters with visual blockage indicator Series MX - dimensions

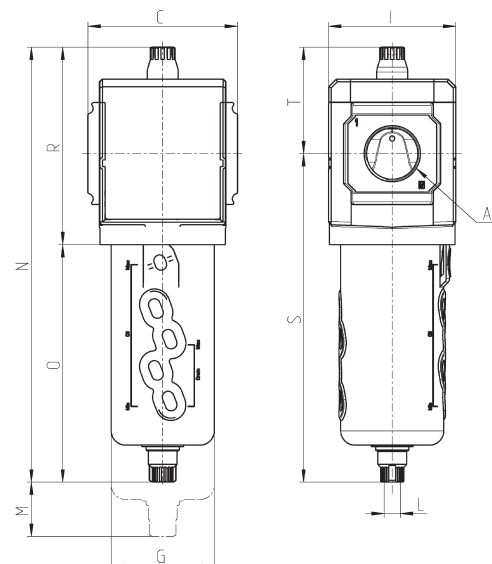

Mod.	A	C	G	I	L	M	N	O	R	S	T	Weight (Kg)
MX2-3/8-FC001	G3/8	70	55.3	68	G1/8	52	231	127	104	174.5	56.5	0.5
MX2-1/2-FC001	G1/2	70	55.3	68	G1/8	52	231	127	104	174.5	56.5	0.5
MX2-3/4-FC001	G3/4	70	55.3	68	G1/8	52	231	127	104	174.5	56.5	0.5
MX3-3/4-FC001	G3/4	89.5	61.5	76	G1/8	75	260	142	118	196.5	63.5	0.8
MX3-1-FC001	G1	89.5	61.5	76	G1/8	75	260	142	118	196.5	63.5	0.8

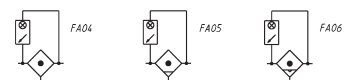

FA04 = coalescing filter without drain, with port G1/8 and visual blockage indicator
 FA05 = coalescing filter with semi-automatic manual drain and visual blockage indicator
 FA06 = coalescing filter with automatic or depressuring drain and visual blockage indicator

Series MX activated carbon filters

New versions

MX2 ports: G3/8, G1/2, G3/4 - MX3 ports: G3/4, G1
Modular
Bowl with technopolymer cover and bayonet-type mounting



- » Removal of compressed air oil, liquid, and gas components through the activated carbon
- » Quality of delivered air according to ISO 8573-1:2010, Class 1.7.1
- » Bowl locking system reducing the risk of accidents
- » Visual blockage indicator

MX is the new series of air treatment components realized by Camozzi, characterized by a modern, linear and compact design, offering high performances. The perfect integration between metal alloys and technopolymers has allowed the realization of a reliable product, light and strong at the same time. Thanks to a new concept of modularity, moreover, the mounting of components has become easier.

The Series MX has been realized to offer a multi-sector solution that guarantees saving in terms of installation time, space and costs.

A special configurator, available on Camozzi website at <http://catalogue.camozzi.com> (sec. Configurators), allows the customer to choose the most suitable solution for his application, selecting single components or by configuring assembled FRLs.

GENERAL DATA

Construction	modular, compact with activated carbon filtering element
Materials	see TABLE OF MATERIALS on the following page
Ports	MX2: G3/8 - G1/2 - G3/4 MX3: G3/4 - G1
Mounting	vertical in-line wall-mounting (by means of clamps)
Operating temperature	10°C ÷ 40°C (t max = 60°C)
Quality of delivered air according to ISO 8573-1:2010	Class 1.7.1
Draining of condensate	No draining
Operating pressure	0.3 ÷ 16 bar
Nominal flow	see FLOW DIAGRAMS on the following pages
Filtering element	activated carbon
Residual oil content	< 0,003 mg/m ³
Fluid	compressed air
Pre-filtering	it is recommended to use a filter with residual oil of 0,01mg/m ³

CODING EXAMPLE

MX	2	-	1/2	-	FCA	1	-	LH
-----------	----------	----------	------------	----------	------------	----------	----------	-----------

MX	SERIES
2	SIZE: 2 = G3/8 - G1/2 - G3/4 3 = G3/4 - G1
1/2	PORT: 1/2 = G1/2 3/4 = G3/4 1 = G1
FCA	ACTIVATED CARBON FILTER
1	VISUAL BLOCKAGE INDICATOR: = not present 1 = present
LH	FLOW DIRECTION: = from left to right (standard) LH = from right to left

SERIES MX ACTIVATED CARBON FILTERS

For the assembly of a single component with fixing flanges or wall-mounting, see the section "FRL Series MX Assembled"

Activated carbon filters Series MX - materials

A = filter
B = filter with visual blockage indicator

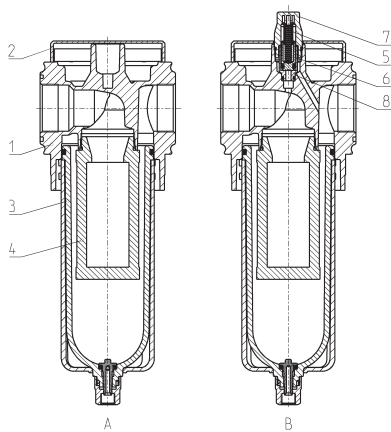

PARTS	MATERIALS
1 = Body	Aluminium
2 = Covering	Polyacetal
3 = Bowl / bowl cover	Polycarbonate/Polyamide
4 = Filtering element	Activated carbon
5 = Upper spring	Stainless steel
6 = Piston	Anodized aluminium
7 = Viewer	Polycarbonate
8 = Indicator body	Brass
Seals	NBR

FLOW DIAGRAMS

SERIES MX ACTIVATED CARBON FILTERS

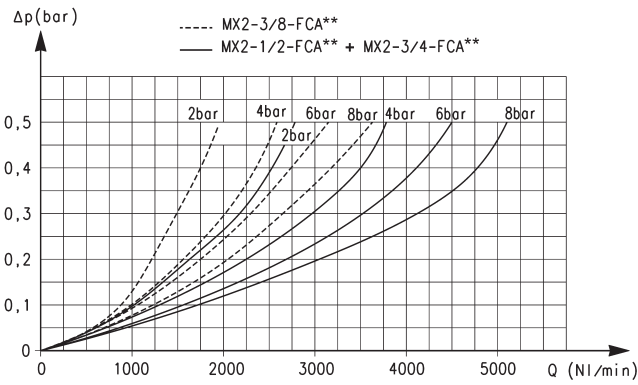

* Reference diagram for MX2

Δp = Pressure drop (bar)
 Q = Flow (NL/min)

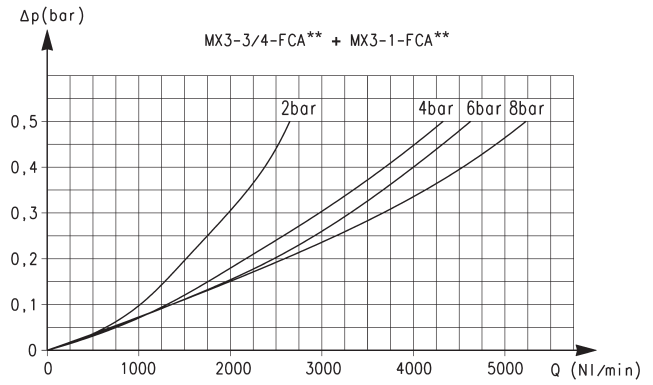

** Reference diagram for MX3

Δp = Pressure drop (bar)
 Q = Flow (NL/min)

Activated carbon filters Series MX - dimensions



FC01 = activated carbon filter

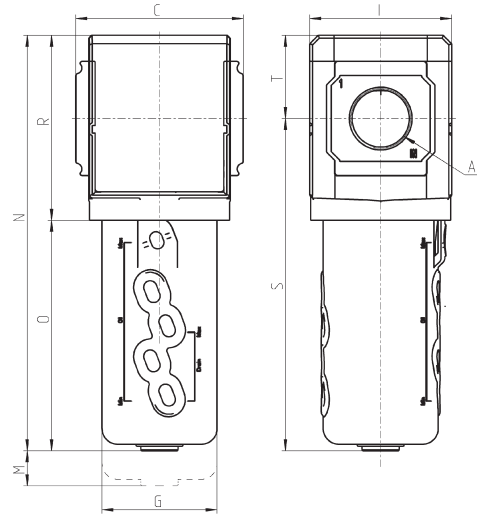
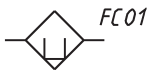

Mod.	A	C	G	I	M	N	O	R	S	T	Weight (Kg)
MX2-3/8-FCA	G3/8	70	55.3	68	89.5	189.5	104.5	85	152	37.5	0.5
MX2-1/2-FCA	G1/2	70	55.3	68	89.5	189.5	104.5	85	152	37.5	0.5
MX2-3/4-FCA	G3/4	70	55.3	68	89.5	189.5	104.5	85	152	37.5	0.5
MX3-3/4-FCA	G3/4	89.5	61.5	76	107	222	123	99	177.5	44.5	0.8
MX3-1-FCA	G1	89.5	61.5	76	107	222	123	99	177.5	44.5	0.8

Activated carbon filters Series MX - dimensions



FC02 = activated carbon filter with visual blockage indicator

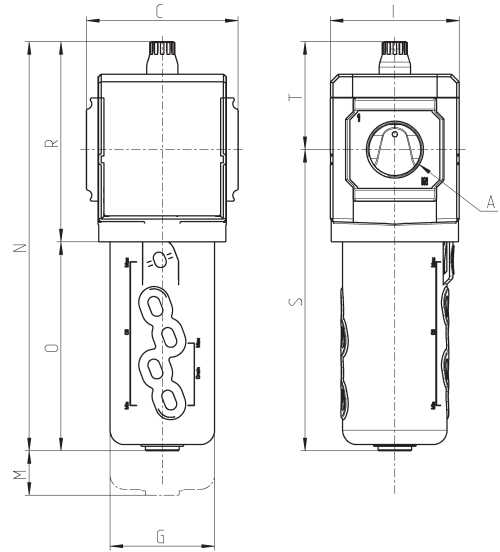
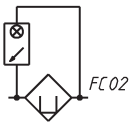

Mod.	A	C	G	I	M	N	O	R	S	T	Weight (Kg)
MX2-3/8-FCA1	G3/8	70	55.3	68	89.5	208.5	104.5	104	152	56.5	0.5
MX2-1/2-FCA1	G1/2	70	55.3	68	89.5	208.5	104.5	104	152	56.5	0.5
MX2-3/4-FCA1	G3/4	70	55.3	68	89.5	208.5	104.5	104	152	56.5	0.5
MX3-3/4-FCA1	G3/4	89.5	61.5	76	107	241	123	118	177.5	63.5	0.8
MX3-1-FCA1	G1	89.5	61.5	76	107	241	123	118	177.5	63.5	0.8

Series MX pressure regulators

MX2 ports: G3/8, G1/2, G3/4 - MX3 ports: G3/4, G1

Manifold ports: G1/2 (MX2 only)

Modular - Available with built-in pressure gauges or ports for gauges

SERIES MX PRESSURE REGULATORS



- » Minimal pressure decreases
- » Knob with closure
- » Tamper-proof system (lockable regulator)
- » Integral return exhaust (relieving)
- » Available versions: Manifold, with by-pass valve

The availability of constant values of the secondary pressure ensures performance optimization and energy saving. The tamper-proof system allows to adjust pressure safely with primary pressure compensation. All reducers are equipped with an integrated locking system and built-in pressure gauges for a more compact product. The regulators Series MX are suitable also for panel mountings.

The Series MX has been realized to offer a multi-sector solution that guarantees saving in terms of installation time, space and costs.

A special configurator, available on Camozzi website at <http://catalogue.camozzi.com> (sec. Configurators), allows the customer to choose the most suitable solution for his application, selecting single components or by configuring assembled FRLs.

GENERAL DATA

Construction	modular, compact, diaphragm type
Materials	see TABLE OF MATERIALS on the following page
Ports	MX2: G3/8 - G1/2 - G3/4 - MX3: G3/4 - G1 Manifold regulator: G1/2 (MX2 only)
Mounting	vertical in-line, wall-mounting (by means of clamps), panel mounting
Operating temperature	-5°C ÷ 50°C up to 16 bar (with the dew point of the fluid lower than 2°C at the min. working temperature) -5°C ÷ 60°C up to 10 bar (with the dew point of the fluid lower than 2°C at the min. working temperature)
Inlet pressure	0 ÷ 16 bar
Outlet pressure	0.5 ÷ 10 bar (standard) 0.5 ÷ 4 bar 0.5 ÷ 7 bar (MX2 only)
Overpressure exhaust	with relieving (standard) or without relieving
Nominal flow	see FLOW DIAGRAMS on the following pages
Fluid	compressed air
Pressure gauge	built-in pressure gauge (standard) with G1/4 port (MX3 only) or G1/8 port (MX2 only)

CODING EXAMPLE

MX	2	-	3/8	-	R	0	0	4	-	LH
-----------	----------	----------	------------	----------	----------	----------	----------	----------	----------	-----------

MX	SERIES
2	SIZE: 2 = G3/8 - G1/2 - G3/4 3 = G3/4 - G1
3/8	PORTS: 3/8 = G3/8 1/2 = G1/2 3/4 = G3/4 1 = G1
R	TYPER OF REGULATOR: R = pressure regulator M = Manifold pressure regulator (MX2 - G1/2 only)
0	OPERATING PRESSURE (1 bar = 14,5 psi): 0 = 0.5 ÷ 10 bar (standard) 4 = 0.5 ÷ 4 bar 7 = 0.5 ÷ 7 bar (MX2 only)
0	DESIGN TYPE: 0 = relieving (standard) 1 = without relieving 2 = relieving, with by-pass valve (only regulator) 3 = without relieving, with by-pass valve (only regulator)
4	PRESSURE GAUGE: 0 = without pressure gauge (with threaded port for gauges) 2 = with built-in pressure gauge 0-6 and working pressure 0.5 ÷ 4 bar 3 = with built-in pressure gauge 0-10 and working pressure 0.5 ÷ 7 bar (MX2 only) 4 = with built-in pressure gauge 0-12 and working pressure 0.5 ÷ 10 bar (standard)
LH	FLOW DIRECTION: = from left to right (standard) LH = from right to left

SERIES MX PRESSURE REGULATORS

For the assembly of a single component with fixing flanges or wall-mounting, see the section "FRL Series MX Assembled"

Pressure regulators Series MX - materials

R = pressure regulator
M = Manifold pressure regulator

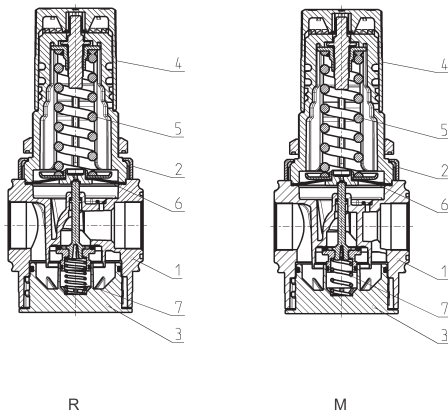

PARTS	MATERIALS
1 = Body	Aluminium
2 = Covering	Polyacetal
3 = Valve holder plug	Polyacetal
4 = Regulator knob	Polyamide
5 = Upper spring	Zinc-plated steel
6 = Diaphragm	NBR
7 = Lower spring	Stainless steel
Seals	NBR

MX2 PRESSURE REGULATORS FLOW DIAGRAMS

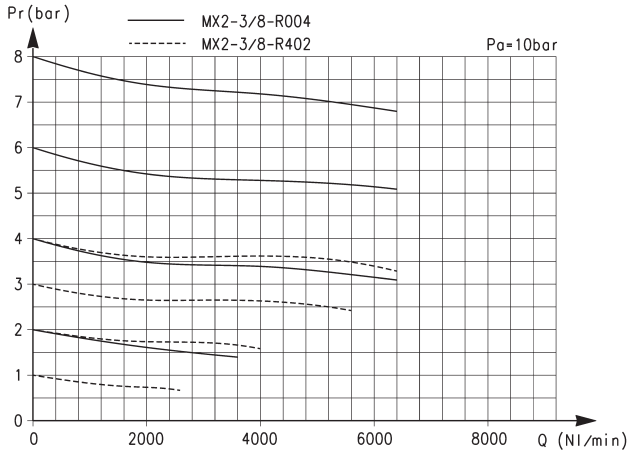

Pr = Regulated pressure (bar)
Q = Flow (NI/min)

Pa = Inlet pressure (bar)

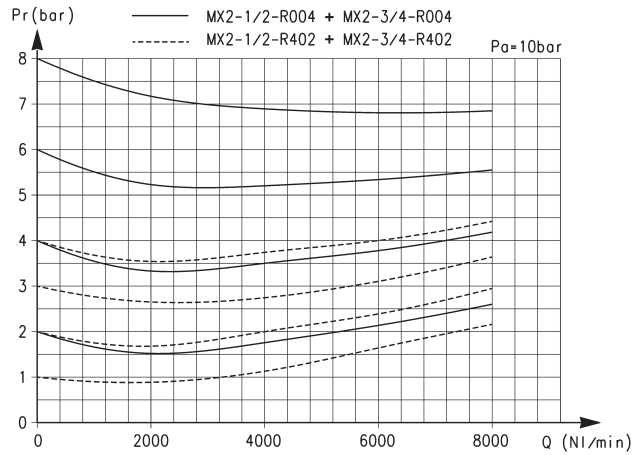

Pr = Regulated pressure (bar)
Q = Flow (NI/min)

Pa = Inlet pressure (bar)

MX3 PRESSURE REGULATORS FLOW DIAGRAM AND PNEUMATIC SYMBOLS

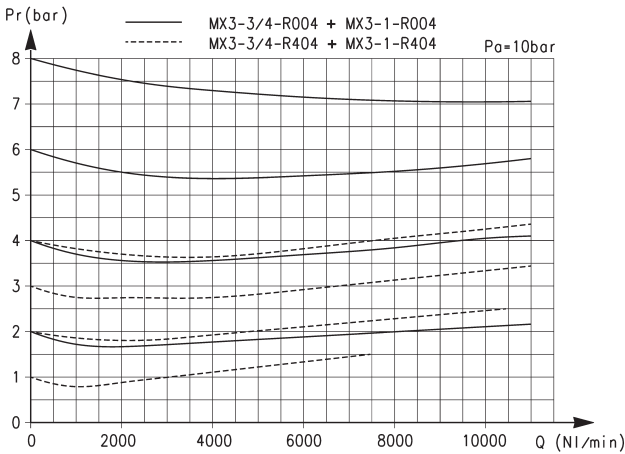

Pr = Regulated pressure (bar)
Q = Flow (NI/min)

Pa = Inlet pressure (bar)

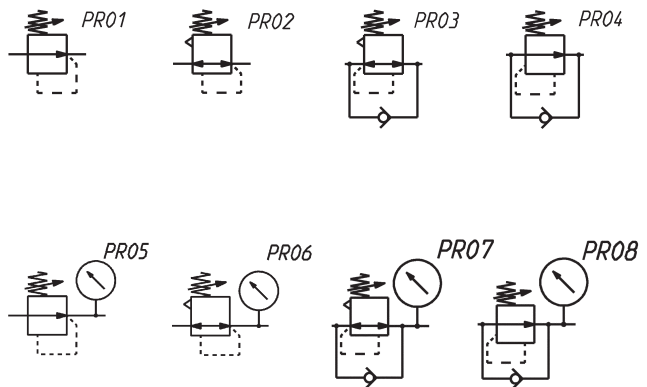

- PR01 = regulator without relieving
- PR02 = regulator with relieving
- PR03 = regulator with relieving and by-pass valve
- PR04 = regulator without relieving with by-pass valve
- PR05 = regulator without relieving and with pressure gauge
- PR06 = regulator with relieving and pressure gauge
- PR07 = regulator with relieving, by-pass valve and pressure gauge
- PR08 = reg. without reliev. with by-pass valve and pressure gauge

Pressure regulators Series MX - dimensions

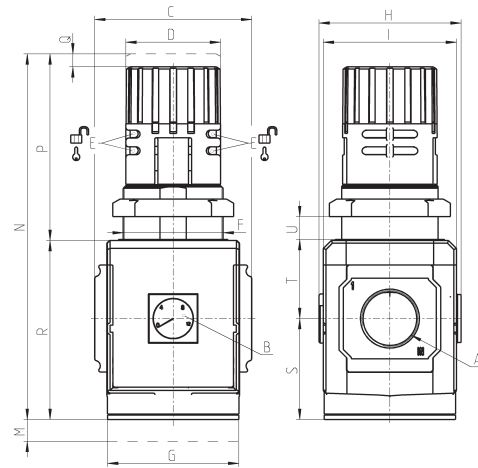

Mod.	A	B (bar)	C	D	E	F	G	H	I	M	N	P	Q	R	S	T	U	Weight (Kg)
MX2-3/8-R004	G3/8	0 ÷ 12	70	45	∅ 4	M47x1,5	70	74,5	68	45	166	78	5	88	50,5	37,5	0 ÷ 13	0.6
MX2-1/2-R004	G1/2	0 ÷ 12	70	45	∅ 4	M47x1,5	70	74,5	68	45	166	78	5	88	50,5	37,5	0 ÷ 13	0.6
MX2-3/4-R004	G3/4	0 ÷ 12	70	45	∅ 4	M47x1,5	70	74,5	68	45	166	78	5	88	50,5	37,5	0 ÷ 13	0.6
MX3-3/4-R004	G3/4	0 ÷ 12	89,5	54	∅ 4	M57x1,5	75	81	76	45	206	104	5	102	57,5	44,5	0 ÷ 20	1
MX3-1-R004	G1	0 ÷ 12	89,5	54	∅ 4	M57x1,5	75	81	76	45	206	104	5	102	57,5	44,5	0 ÷ 20	1

MANIFOLD REGULATOR - FLOW DIAGRAM and PNEUMATIC SYMBOLS

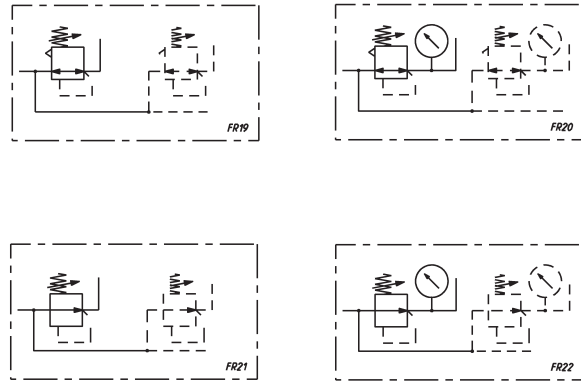
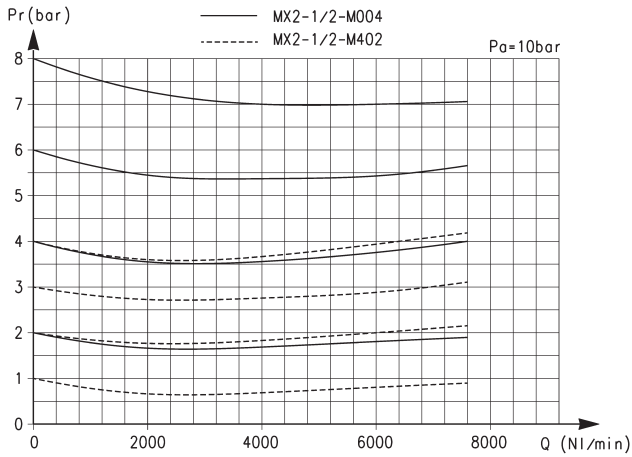

Pr = Regulated pressure (bar)
Q = Flow (NI/min)

Pa = Inlet pressure (bar)

FR19 = Manifold reg. with relieving and without pressure gauge
FR20 = Manifold reg. with relieving and pressure gauge
FR21 = Manifold reg. without relieving or pressure gauge
FR22 = Manifold reg. without relieving and with pressure gauge

SERIES MX PRESSURE REGULATORS

MANIFOLD pressure regulator Series MX - dimensions



The picture on the left side shows that it is possible to assembly a certain number of regulators with the same inlet pressure using proper mounting kits, with or without terminals.
The regulation of the outlet pressure (OUT port) of each regulator can be set up rotating the knob clockwise or anticlockwise until the desired pressure is reached.
This regulation has no effect on pressures of previous or following regulators.

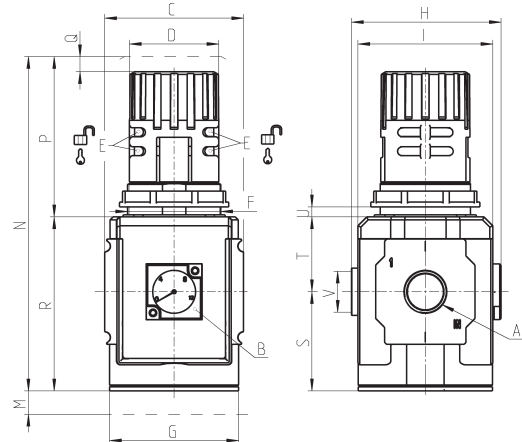

Mod.	A	B (bar)	C	D	E	F	G	H	I	M	N	P	Q	R	S	T	U	V (OUT)	Weight (Kg)
MX2-1/2-M004	G1/2	0 ÷ 12	70	45	Ø 4	M47x1,5	70	75,5	68	45	166	78	5	88	50,5	37,5	0 ÷ 13	G1/2	0,6

Series MX pneumatic pilot operated pressure regulators



Ports: G3/8, G1/2, G3/4

Modular - Available with built-in pressure gauges or ports for gauges



- » Pneumatically operated regulation
- » Minimal pressure decreases
- » Integral return exhaust (relieving)

The availability of constant values of the secondary pressure ensures performance optimization and energy saving. All regulators are equipped with an integrated locking system and built-in pressure gauges for a more compact product.

The Series MX has been realized to offer a multi-sector solution that guarantees saving in terms of installation time, space and costs.

A special configurator, available on Camozzi website at <http://catalogue.camozzi.com> (sec. Configurators), allows the customer to choose the most suitable solution for his application, selecting single components or by configuring assembled FRLs.

GENERAL DATA

Construction	modular, compact, diaphragm type
Materials	see TABLE OF MATERIALS on the following page
Ports	G3/8 - G1/2 - G3/4
Mounting	vertical in-line wall-mounting (by means of clamps)
Operating temperature	-5°C ÷ 50°C up to 16 bar (with the dew point of the fluid lower than 2°C at the min. working temperature) -5°C ÷ 60°C up to 10 bar (with the dew point of the fluid lower than 2°C at the min. working temperature)
Inlet pressure	0 ÷ 16 bar
Outlet pressure	10 bar
Overpressure exhaust	with relieving (standard) without relieving
Nominal flow	see FLOW DIAGRAMS on the following pages
Fluid	compressed air
Pressure gauge	built-in pressure gauge (standard) with G1/8 port

CODING EXAMPLE

MX	2	-	1/2	-	R	CP	0	0	4	-	LH
-----------	----------	----------	------------	----------	----------	-----------	----------	----------	----------	----------	-----------

MX	SERIES
2	SIZE: 2 = G3/8 - G1/2 - G3/4
1/2	PORTS: 3/8 = G3/8 1/2 = G1/2 3/4 = G3/4
R	TYPER OF REGULATOR: R = pressure regulator
CP	TYPE OF COMMAND/PILOT SUPPLY: CP = pneumatic pilot supply
0	OPERATING PRESSURE: 0 = 0.5 ÷ 10 bar
0	DESIGN TYPE: 0 = relieving (standard) 1 = without relieving
4	PRESSURE GAUGE: 0 = without pressure gauge (with threaded port for gauges) 4 = with built-in pressure gauge 0-12 and working pressure 0.5 ÷ 10 bar (standard)
LH	FLOW DIRECTION: = from left to right (standard) LH = from right to left

SERIES MX PNEUMATIC PILOT OPERATED PRESSURE REGULATORS

For the assembly of a single component with fixing flanges or wall-mounting, see the section "FRL Series MX Assembled"

Pneumatic pilot operated pressure regulators Series MX - materials

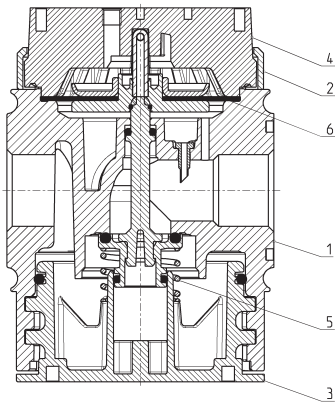

PARTS	MATERIALS
1 = Body	Aluminium
2 = Covering	Polyacetal
3 = Valve holder plug	Polyacetal
4 = Upper base	Polyamide
5 = Lower spring	Stainless steel
6 = Diaphragm	NBR
Seals	NBR

DIAGRAMS OF PNEUMATIC PILOT OPERATED PRESSURE REGULATORS

MX2-3/8-RCP000

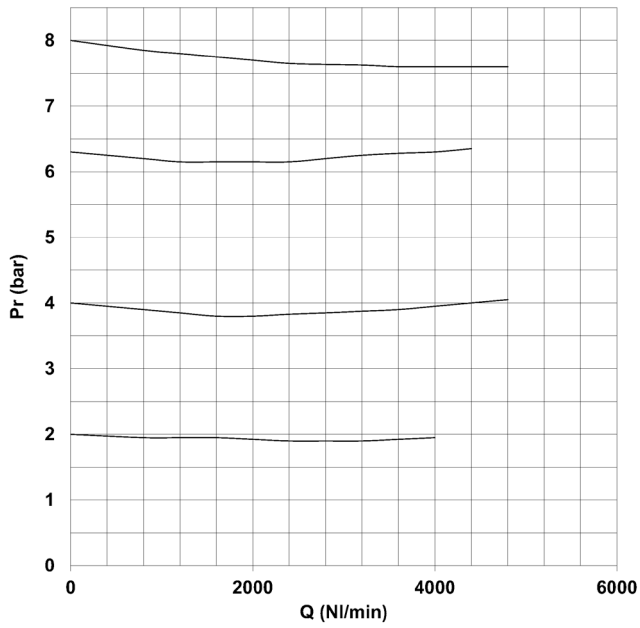

Pr = Regulated pressure (bar)
Q = Flow (NL/min)

Inlet pressure = 10bar

MX2-1/2-RCP000

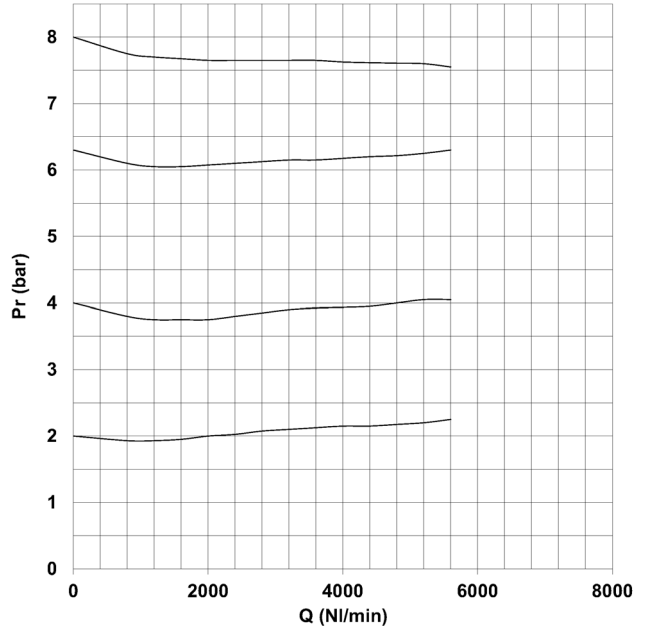

Pr = Regulated pressure (bar)
Q = Flow (NL/min)

Inlet pressure = 10bar

MX2-3/4-RCP000

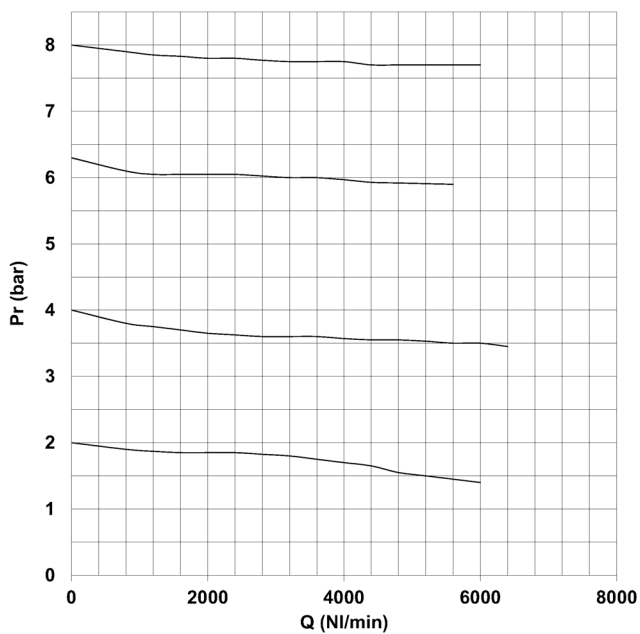

Pr = Regulated pressure (bar)
Q = Flow (NL/min)

Inlet pressure = 10bar

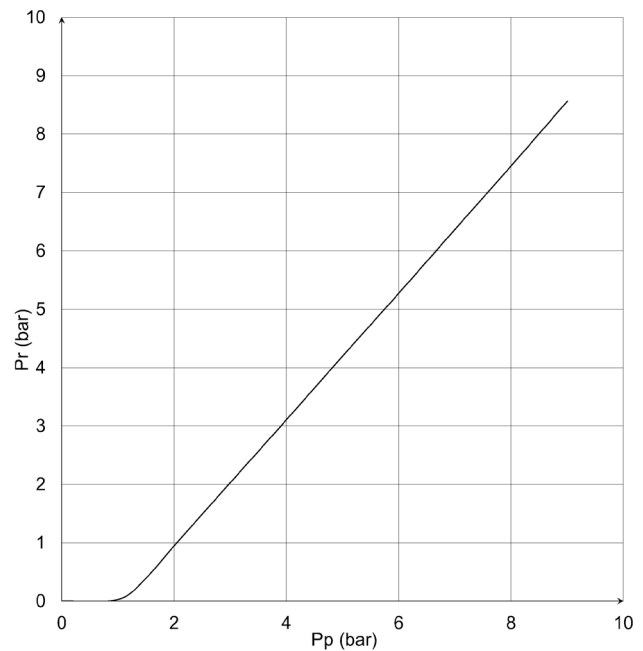

ADJUSTMENT CURVE

Pr = regulated pressure (bar)
Pp = pilot pressure (bar)

Inlet pressure = 10bar

SERIES MX PNEUMATIC PILOT OPERATED PRESSURE REGULATORS

Pneumatic pilot operated pressure regulators Series MX - dimensions



PR09 = reg. with relieving
 PR10 = regulator with relieving and pressure gauge
 PR11 = regulator without relieving
 PR12 = regulator without relieving and with pressure gauge

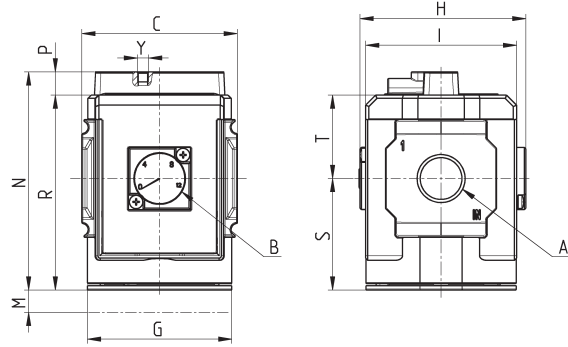
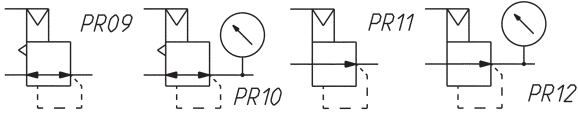

Mod.	A	B (bar)	C	G	H	I	M	Y (Pilot supply)	N	P	R	S	T	Weight (Kg)
MX2-3/8-RCP004	G3/8	0 ÷ 12	70	65	74.5	68	45	M5	98	10	88	50.5	37.5	0.5
MX2-1/2-RCP004	G1/2	0 ÷ 12	70	65	74.5	68	45	M5	98	10	88	50.5	37.5	0.5
MX2-3/4-RCP004	G3/4	0 ÷ 12	70	65	74.5	68	45	M5	98	10	88	50.5	37.5	0.5

SERIES MX PNEUMATIC PILOT OPERATED PRESSURE REGULATORS

Series MX lubricators



MX2 ports: G3/8, G1/2, G3/4 - MX3 ports: G3/4, G1
Modular
Bowl with technopolymer cover and bayonet-type mounting



- » Regulation screw
- » Ability to refill the oil even with system under pressure
- » High flow
- » Check of the oil level through plastic cover openings
- » Bowl locking system reducing the risk of accidents

MX is the new series of air treatment components realized by Camozzi, characterized by a modern, linear and compact design, offering high performances. The perfect integration between metal alloys and technopolymers has allowed the realization of a reliable product, light and strong at the same time. Thanks to a new concept of modularity, moreover, the mounting of components has become easier. These proportional lubricators enable a precision metering.

The Series MX has been realized to offer a multi-sector solution that guarantees saving in terms of installation time, space and costs.

A special configurator, available on Camozzi website at <http://catalogue.camozzi.com> (sec. Configurators), allows the customer to choose the most suitable solution for his application, selecting single components or by configuring assembled FRLs.

GENERAL DATA

Construction	modular, compact
Materials	see TABLE OF MATERIALS on the following page
Ports	MX2: G3/8 - G1/2 - G3/4 MX3: G3/4 - G1
Oil capacity	MX2: 170 cm ³ MX3: 230 cm ³
Oil refilling	even during use
Mounting	vertical in-line wall-mounting (by means of clamps)
Operating temperature	-5°C ÷ 50°C up to 16 bar (with the dew point of the fluid lower than 2°C at the min. working temperature) -5°C ÷ 60°C up to 10 bar (with the dew point of the fluid lower than 2°C at the min. working temperature)
Oil for lubrication	use ISO VG32 oils. Once applied, the lubrication should never be interrupted.
Operating pressure	0 ÷ 16 bar
Min. air consumption for lubrication at 1 bar	MX2: 17 l/min MX3: 50 l/min
Min. air consumption for lubrication at 6 bar	MX2: 38 l/min MX3: 90 l/min
Nominal flow	see FLOW DIAGRAMS on the following pages

CODING EXAMPLE

MX	2	-	1/2	-	L	00	-	LH
-----------	----------	----------	------------	----------	----------	-----------	----------	-----------

MX	SERIES
2	SIZE: 2 = G3/8 - G1/2 - G3/4 3 = G3/4 - G1
1/2	PORT: 1/2 = G1/2 3/4 = G3/4 1 = G1
L	LUBRICATOR
00	DESIGN TYPE: 00 = atomized oil
LH	FLOW DIRECTION: = from left to right (standard) LH = from right to left

SERIES MX LUBRICATORS

For the assembly of a single component with fixing flanges or wall-mounting, see the section "FRL Series MX Assembled"

Lubricators Series MX - materials

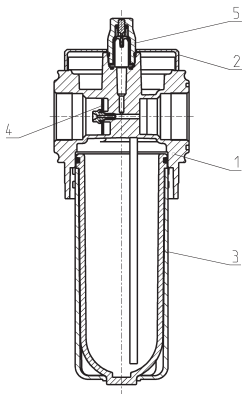

PARTS	MATERIALS
1 = Body	Aluminium
2 = Covering	Polyacetal
3 = Bowl / bowl cover	Polycarbonate/Polyamide
4 = Diaphragm	NBR
5 = Visual indicator	Polyamide
Seals	NBR

FLOW DIAGRAMS

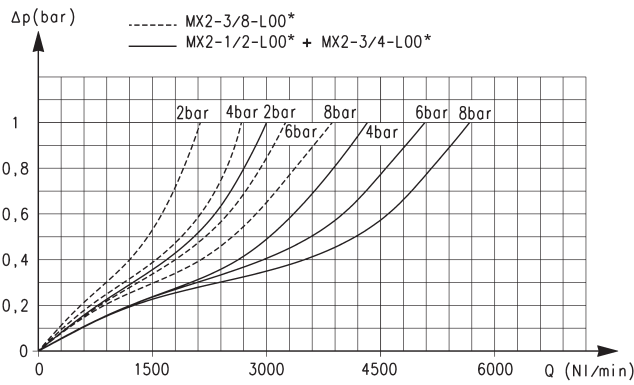

Reference diagram for MX2

Δp = Pressure drop (bar)
 Q = Flow (NI/min)

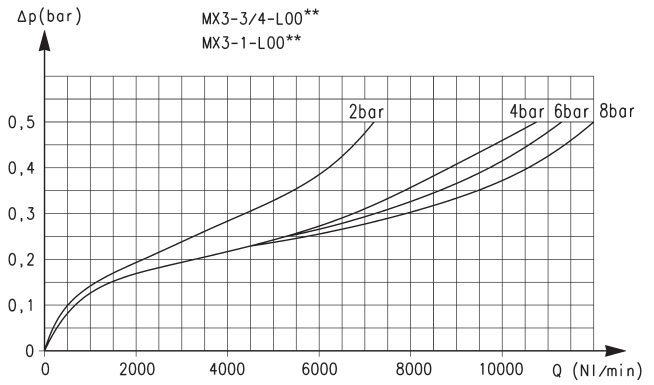

Reference diagram for MX3

Δp = Pressure drop (bar)
 Q = Flow (NI/min)

SERIES MX LUBRICATORS

Lubricators Series MX - dimensions



LU0 = lubricator

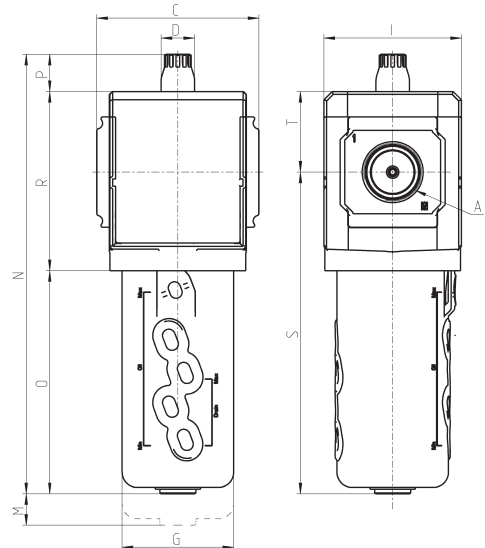
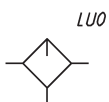

Mod.	A	C	D	G	I	M	N	O	P	R	S	T	Weight (Kg)
MX2-3/8-L00	G3/8	70	18.5	55.5	68	84.5	210	104.5	20.5	85	152	37.5	0.5
MX2-1/2-L00	G1/2	70	18.5	55.5	68	84.5	210	104.5	20.5	85	152	37.5	0.5
MX2-3/4-L00	G3/4	70	18.5	55.5	68	84.5	210	104.5	20.5	85	152	37.5	0.5
MX3-3/4-L00	G3/4	89.5	18.5	61.5	76	100	243	123	21	99	178	44.5	0.8
MX3-1-L00	G1	89.5	18.5	61.5	76	100	243	123	21	99	178	44.5	0.8

Series MX filter-regulators

MX2 ports: G3/8, G1/2, G3/4 - MX3 ports: G3/4, G1
Modular

Bowl with technopolymer cover and bayonet-type mounting



- » Quality of delivered air according to ISO 8573-1:2010, Classes 7.8.4 and 6.8.4
- » With built-in pressure gauge or with ports for pressure gauge
- » Lockable knob
- » Polymer bowl locking system reducing the risk of accidents

Series MX filter-regulators integrate filter and pressure reducer in one unit. They are, therefore, compact and suitable for pre-filtering functions.

Available with or without draining (relieving), they are equipped with a valve diaphragm for a direct pressure regulation and with an integrated condensate drainer, manual or automatic. Moreover, they are equipped with a built-in pressure gauge.

The Series MX has been realized to offer a multi-sector solution that guarantees saving in terms of installation time, space and costs.

A special configurator, available on Camozzi website at <http://catalogue.camozzi.com> (sec. Configurators), allows the customer to choose the most suitable solution for his application, selecting single components or by configuring assembled FRLs.

GENERAL DATA

Construction	modular, compact with filtering element in HDPE
Materials	see TABLE OF MATERIALS on the following page
Ports	MX2: G3/8 - G1/2 - G3/4 - MX3: G3/4 - G1
Condensate capacity	MX2: 55 cc - MX3: 85 cc
Mounting	vertical in-line, wall-mounting (by means of clamps), panel mounting
Operating temperature	-5°C ÷ 50°C up to 16 bar (with the dew point of the fluid lower than 2°C at the min. working temperature) -5°C ÷ 60°C up to 10 bar (with the dew point of the fluid lower than 2°C at the min. working temperature)
Quality of delivered air according to ISO 8573-1:2010	Class 6.8.4 with 5 µm filtering element Class 7.8.4 with 25 µm filtering element
Draining of condensate	MX2: manual-semi automatic (standard), automatic, depressurization protected, direct G1/8 exhaust MX3: manual-semi automatic (standard), automatic, direct G1/8 exhaust
Inlet pressure	0.3 ÷ 16 bar (with automatic drain 1.5 ÷ 12)
exit pressure	0.5 ÷ 10 bar (standard), 0.5 ÷ 4 bar and 0.5 ÷ 7 bar
Nominal flow	see FLOW DIAGRAMS on the following pages
Fluid	compressed air
Pressure gauge	built-in pressure gauge (standard) with G1/4 port (MX3 only) or G1/8 port (MX2 only)

CODING EXAMPLE

MX	2	-	1/2	-	FR	0	0	0	4	-	LH
-----------	----------	----------	------------	----------	-----------	----------	----------	----------	----------	----------	-----------

MX	SERIES
2	SIZE: 2 = G3/8 - G1/2 - G3/4 3 = G3/4 - G1
1/2	PORT: 3/8 = G3/8 1/2 = G1/2 3/4 = G3/4 1 = G1
FR	FILTER-REGULATOR
0	FILTERING ELEMENT WITH DESIGN TYPE: 0 = 25 µm with relieving (standard) 1 = 5 µm with relieving 2 = 25 µm without relieving (with semiautomatic-manual drain only) 3 = 5 µm without relieving (with semiautomatic-manual drain only) 4 = 25 µm with relieving and by-pass valve 5 = 5 µm with relieving and by-pass valve 6 = 25 µm without relieving, with by-pass valve 7 = 5 µm without relieving, with by-pass valve
0	DRAINING OF CONDENSATE (further details in the dedicated section): 0 = semiautomatic-manual drain (standard - only for polymer bowl) 3 = automatic drain 5 = depressuring drain, protected (only for polymer bowl) 8 = without drain, with port G1/8
0	OPERATING PRESSURE: 0 = 0.5 ÷ 10 bar (standard) 4 = 0.5 ÷ 4 bar 7 = 0.5 ÷ 7 bar (MX2 only)
4	PRESSURE GAUGE: 0 = without pressure gauge (with threaded port) 2 = with built-in pressure gauge 0-6 and working pressure 0.5 ÷ 4 bar 3 = with built-in pressure gauge 0-10 and working pressure 0.5 ÷ 7 bar (MX2 only) 4 = with built-in pressure gauge 0-12 and working pressure 0.5 ÷ 10 bar (standard)
LH	FLOW DIRECTION: = from left to right (standard) LH = from right to left

For the assembly of a single component with fixing flanges or wall-mounting, see the section "FRL Series MX Assembled"

Filter-regulators Series MX - materials

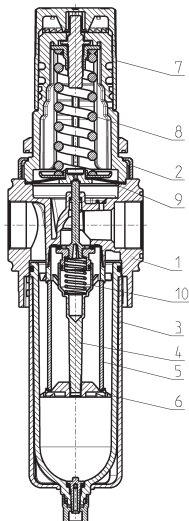

PARTS	MATERIALS
1 = Body	Aluminium
2 = Covering	Polyacetal
3 = Bowl / bowl cover	Polycarbonate/Polyamide
4 = Valve guide	Polyacetal
5 = Filtering element	Polyethylene
6 = Separation deflector	Polyacetal
7 = Knob	Polyamide
8 = Upper spring	Zinc-plated steel
9 = Diaphragm	NBR
10 = Lower spring	Stainless steel
Seals	NBR

MX2 FILTER REGULATORS FLOW DIAGRAMS

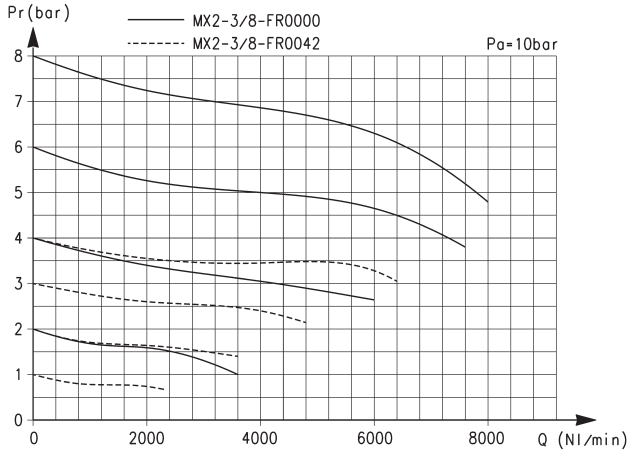

Pr = Regulated pressure
Q = Flow

Pa = Inlet pressure

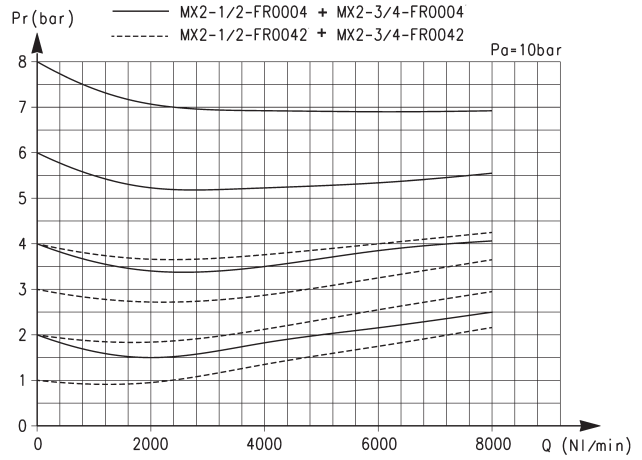

Pr = Regulated pressure
Q = Flow

Pa = Inlet pressure

MX3 FILTER-REGULATORS FLOW DIAGRAM

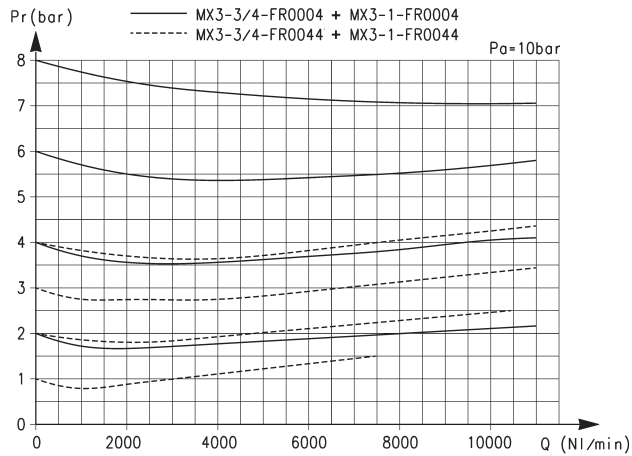

Pr = Regulated pressure
Q = Flow

Pa = Inlet pressure

PNEUMATIC SYMBOLS

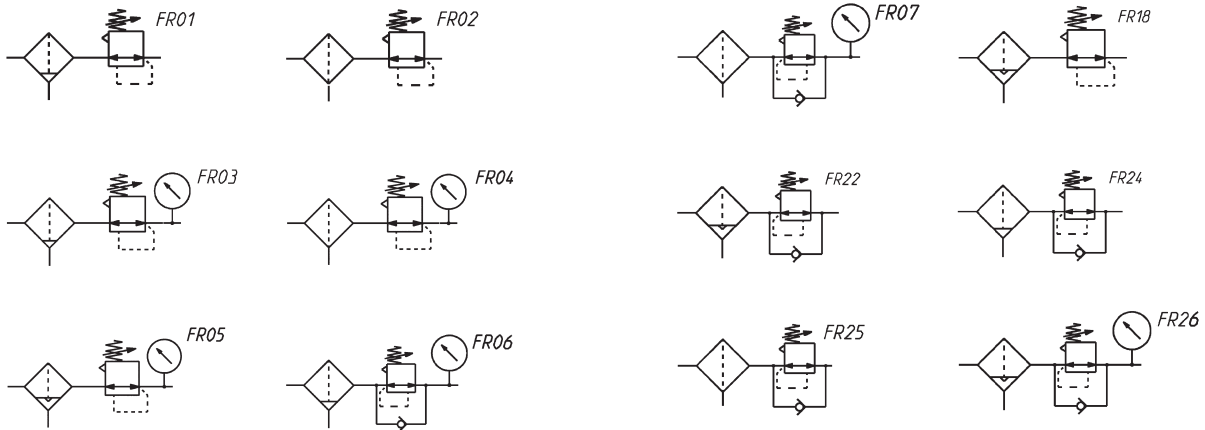

FR01 = filter-reg. with relieving and manual/semiautomatic drain
 FR02 = filter-reg. with relieving and direct exhaust
 FR03 = filter-reg. with relieving, pressure gauge and manual/semiautomatic drain
 FR04 = filter-reg. with relieving, pressure gauge and direct exhaust
 FR05 = filter-reg. with relieving, pressure gauge and automatic drain
 FR06 = filter-reg. with relieving, pressure gauge, manual/semiautomatic drain and by-pass valve

FR07 = filter-reg. with rel., pres. gauge, dir. exh. and by-pass valve
 FR18 = filter-reg. with relieving and automatic drain
 FR22 = filter-reg. without relieving, with pressure gauge, automatic-depressurisation drain and by-pass valve
 FR24 = filter-reg. with rel. and man/semiaut drain and bypass valve
 FR25 = filter-reg. with relieving, direct exhaust and by-pass valve
 FR26 = filter-reg. without relieving, automatic-depressurisation drain and by-pass valve

SERIES MX FILTER-REGULATORS

Filter-regulators Series MX - dimensions

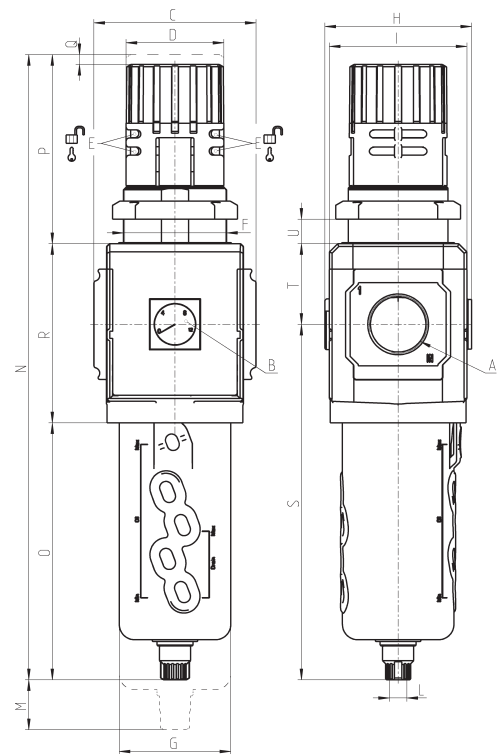

Mod.	A	B (bar)	C	D	E	F	G	H	I	L	M	N	O	P	Q	R	S	T	U	Weight (Kg)
MX2-3/8-FR0004	G3/8	0 ÷ 12	70	45	∅ 4.7	M47x1.5	55.5	74.5	68	G1/8	66	290	127	78	5	85	174.5	37.5	0 ÷ 16	0.8
MX2-1/2-FR0004	G1/2	0 ÷ 12	70	45	∅ 4.7	M47x1.5	55.5	74.5	68	G1/8	66	290	127	78	5	85	174.5	37.5	0 ÷ 16	0.8
MX2-3/4-FR0004	G3/4	0 ÷ 12	70	45	∅ 4.7	M47x1.5	55.5	74.5	68	G1/8	66	290	127	78	5	85	174.5	37.5	0 ÷ 16	0.8
MX3-3/4-FR0004	G3/4	0 ÷ 12	89.5	54	∅ 4	M57x1.5	61.5	81	76	G1/8	75	345	142	104	5	99	196.5	44.5	0 ÷ 20	1.3
MX3-1-FR0004	G1	0 ÷ 12	89.5	54	∅ 4	M57x1.5	61.5	81	76	G1/8	75	345	142	104	5	99	196.5	44.5	0 ÷ 20	1.3

Series MX lockable isolation 3/2-way valves

MX2 ports: G3/8, G1/2, G3/4 - MX3 ports: G3/4, G1
Modular

Manual, electro-pneumatic, servo-pilot and pneumatic control

SERIES MX 3/2-WAY ISOLATION VALVES



- » Standard tamperproof lock-out (manual valve)
- » One/more locks for the lock-out feature (manual valve)
- » Actuation at 24 V, 110 V or 230 V
- » Exhaust in atmosphere

Manual isolation valves are ideal to allow an easy access to the FRL group. The system is depressurized with the de-activation of the valve.

Electropneumatic isolation valves: ideal where manual access is difficult, they allow a maximum positioning flexibility and are designed to pressurize or depressurize pneumatic systems. The built-in manual override guarantees security in case of an emergency.

The Series MX has been realized to offer a multi-sector solution that guarantees saving in terms of installation time, space and costs.

A special configurator, available on Camozzi website at <http://catalogue.camozzi.com> (sec. Configurators), allows the customer to choose the most suitable solution for his application, selecting single components or by configuring assembled FRLs.

GENERAL DATA

Construction	modular, compact, spool-type
Materials	see TABLE OF MATERIALS on the following page
Ports	MX2: G3/8 - G1/2 - G3/4 MX3: G3/4 - G1
Mounting	in-line wall-mounting (by means of clamps)
Operating temperature	-5°C ÷ 50°C up to 16 bar (with the dew point of the fluid lower than 2°C at the min. working temperature) -5°C ÷ 60°C up to 10 bar (with the dew point of the fluid lower than 2°C at the min. working temperature)
Operating pressure	Manual valve: -0,8 bar ÷ 10 bar Electro-pneumatic valve: 2 bar ÷ 10 bar Servopilot or pneumatic valve: -0,8 bar ÷ 10 bar (with pilot 3.5 ÷ 10 bar)
Nominal flow	see FLOW DIAGRAMS on the following pages
Nominal exhaust flow at 6 bar with $\Delta p = 1$ bar	MX2: 6000 NL/min MX3: 9200 NL/min
Fluid	compressed air

CODING EXAMPLE

MX	2	-	3/8	-	V	01	-	LH
MX	SERIES							
2	SIZE: 2 = G3/8 - G1/2 - G3/4 3 = G3/4 - G1							
3/8	PORT: 3/8 = G3/8 1/2 = G1/2 3/4 = G3/4 1 = G1							
V	3/2-WAY VALVE							
01	DESIGN TYPE: 01 = lockable manual control 16 = electro-pneumatic control 17 = servo-pilot control 36 = pneumatic control							
LH	FLOW DIRECTION: = from left to right (standard) LH = from right to left							

For the assembly of a single component with fixing flanges or wall-mounting, see the section "FRL Series MX Assembled"

Lockable isolation 3/2-way valves Series MX - materials

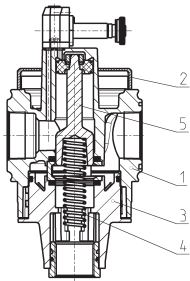

PARTS	MATERIALS
1 = Body	Aluminium
2 = Covering	Polyacetal
3 = Valve holder plug	Polyacetal
4 = Lower spring	Zinc-plated steel
5 = Spool	Stainless steel (MX...V16 - V17 - V36) Aluminium (MX...V01)
Seals	NBR

NOMINAL FLOW DIAGRAM FOR VALVES Mod. MX...V01

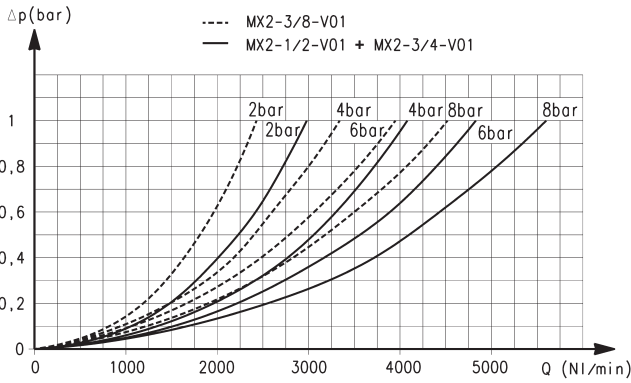

Diagram for lockable manual control valves MX2

Δp = Pressure drop (bar)
Q = Flow (NI/min)

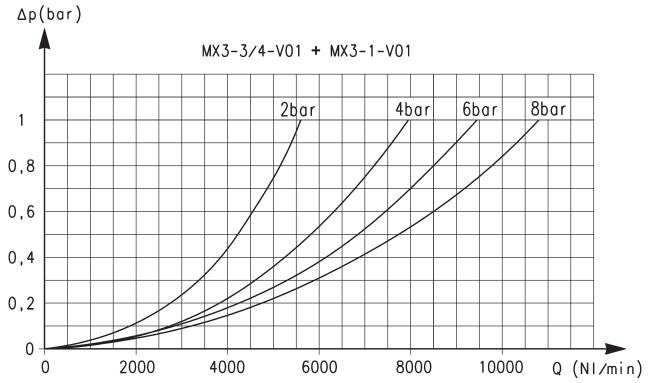

Diagram for lockable manual control valves MX3

Δp = Pressure drop
Q = Flow

Lockable manual valves Series MX - dimensions

Fig. 1 = closed valve
Fig. 2 = open valve



VN27 = Lockable bistable manual valve 3/2

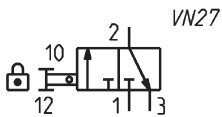
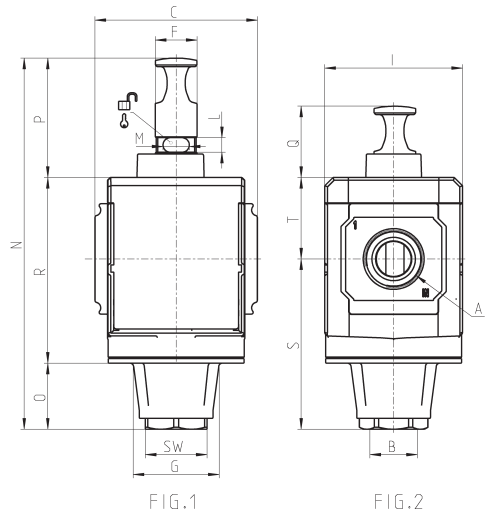

Mod.	A	B	C	F	G	I	L	M	N	O	P	Q	R	S	SW	T	Weight (Kg)
MX2-3/8-V01	G3/8	G 1/2	70	18	34,5	68	9	8	152	13	51	31	88	63,5	27	37,5	0.5
MX2-1/2-V01	G 1/2	G 1/2	70	18	34,5	68	9	8	152	13	51	31	88	63,5	27	37,5	0.5
MX2-3/4-V01	G3/4	G 1/2	70	18	34,5	68	9	8	152	13	51	31	88	63,5	27	37,5	0.5
MX3-3/4-V01	G3/4	G3/4	89,5	23	48	76	8	14,5	205,5	37	66,5	40	102	94,5	34	44,5	0.9
MX3-1-V01	G1	G3/4	89,5	23	48	76	8	14,5	205,5	37	66,5	40	102	94,5	34	44,5	0.9

NOMINAL FLOW DIAGRAMS FOR VALVES Mod. MX...V16

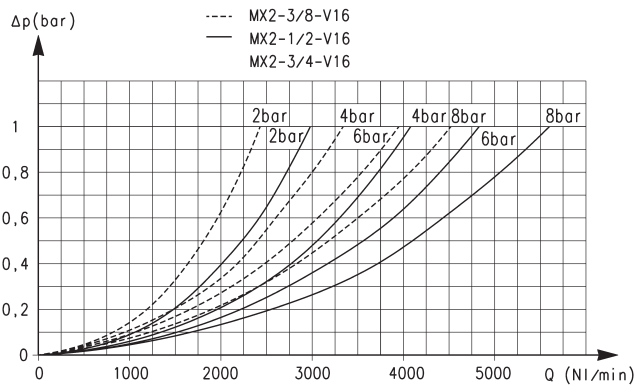

Diagram for electro-pneumatic control valves MX2

Δp = Pressure drop (bar)
 Q = Flow (NI/min)

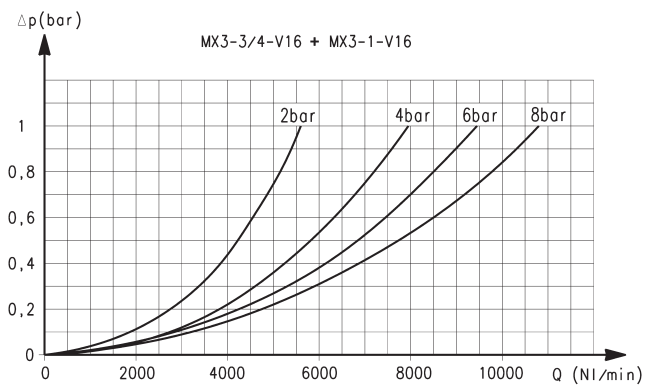

Diagram for electro-pneumatic control valves MX3

Δp = Pressure drop (bar)
 Q = Flow (NI/min)

SERIES MX 3/2-WAY ISOLATION VALVES

Series MX electro-pneumatically operated valves - dimensions



EV10 = solenoid valve, 3/2 NC, monostable, with bistable manual override

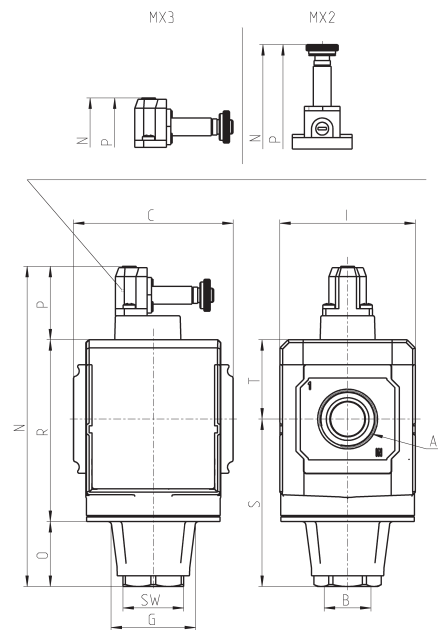
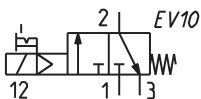

Mod.	A	B	C	G	I	N	O	P	R	S	SW	T	Weight (Kg)
MX2-3/8-V16	G3/8	G1/2	70	34.5	68	171	13	70	88	63.5	34	37.5	0.5
MX2-1/2-V16	G1/2	G1/2	70	34.5	68	171	13	70	88	63.5	34	37.5	0.5
MX2-3/4-V16	G3/4	G1/2	70	34.5	68	171	13	70	88	63.5	34	37.5	0.5
MX3-3/4-V16	G3/4	G3/4	89.5	48	76	180.5	37	41.5	102	94.5	34	44.5	0.9
MX3-1-V16	G1	G3/4	89.5	48	76	180.5	37	41.5	102	94.5	34	44.5	0.9

Series MX pneumatically operated valves - dimensions



YES1 = pneumatically operated valve, 3/2, monostable, mechanical spring

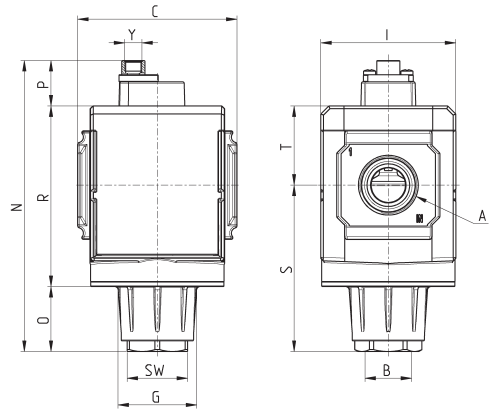
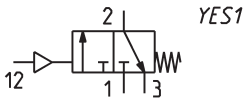

Mod.	A	B	C	G	I	N	O	P	R	S	SW	T	Y (pilot supply)	Weight (Kg)
MX2-3/8-V36	G3/8	G1/2	70	34.5	68	122	13	21	88	63.5	34	37.5	G1/8	0.5
MX2-1/2-V36	G1/2	G1/2	70	34.5	68	122	13	21	88	63.5	34	37.5	G1/8	0.5
MX2-3/4-V36	G3/4	G1/2	70	34.5	68	122	13	21	88	63.5	34	37.5	G1/8	0.5
MX3-3/4-V36	G3/4	G3/4	89.5	48	76	164	37	25.5	102	94.5	34	44.5	G1/8	0.9
MX3-1-V36	G1	G3/4	89.5	48	76	164	37	25.5	102	94.5	34	44.5	G1/8	0.9

SERIES MX 3/2-WAY ISOLATION VALVES

FLOW DIAGRAM for valves Mod. MX...V17

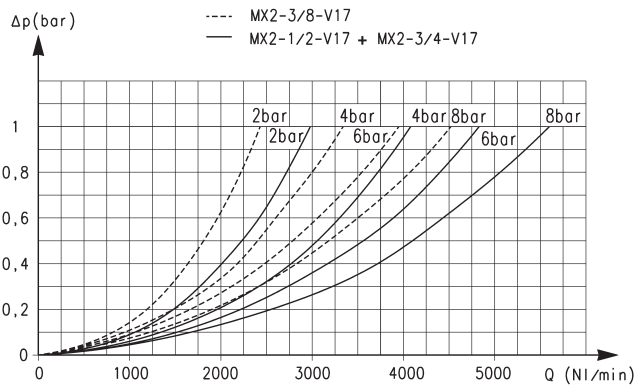

Diagram for servo-pilot control valves MX2

Δp = Pressure drop (bar)
 Q = Flow (NL/min)

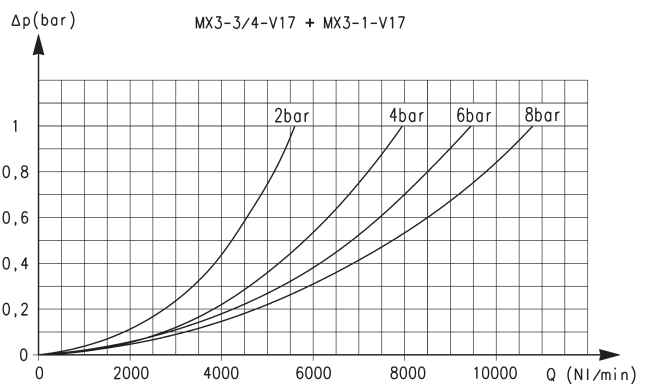

Diagram for servo-pilot control valves MX3

Δp = Pressure drop (bar)
 Q = Flow (NL/min)

SERIES MX 3/2-WAY ISOLATION VALVES

Series MX servo-pilot valves - dimensions



EV53 = solenoid valve, 3/2, monostable, solenoid pilot with separate air supply and bistable manual override

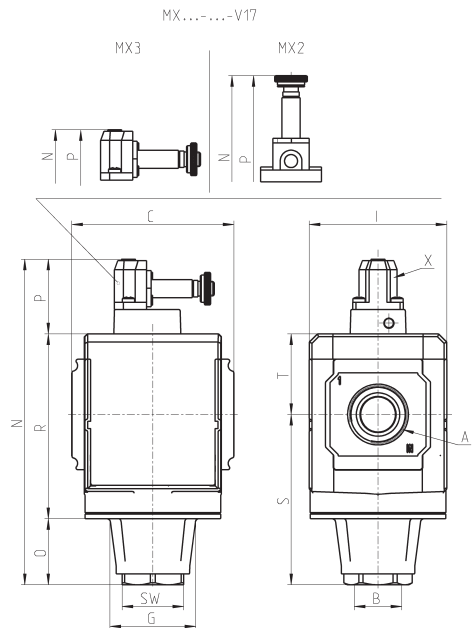
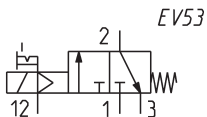

Mod.	A	B	C	G	I	N	O	P	R	S	SW	T	X	Weight (Kg)
MX2-3/8-V17	G3/8	G1/2	70	34,5	68	171	13	70	88	63,5	34	37,5	M5	0.5
MX2-1/2-V17	G1/2	G1/2	70	34,5	68	171	13	70	88	63,5	34	37,5	M5	0.5
MX2-3/4-V17	G3/4	G1/2	70	34,5	68	171	13	70	88	63,5	34	37,5	M5	0.5
MX3-3/4-V17	G3/4	G3/4	89,5	48	76	180,5	37	41,5	102	94,5	34	44,5	M5	0.9
MX3-1-V17	G1	G3/4	89,5	48	76	180,5	37	41,5	102	94,5	34	44,5	M5	0.9

New

Series MX SAFEMAX 3/2-way quick exhaust safety valves

Ports: G1/2

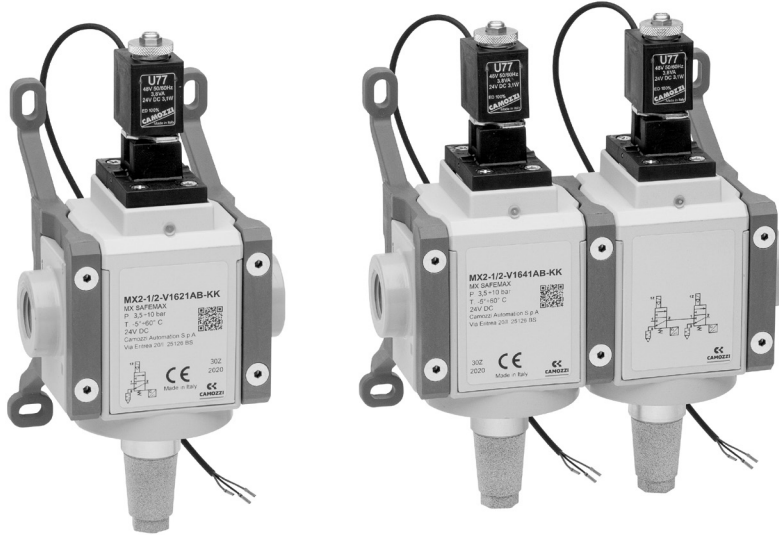

- » According to Machinery Directive 2006/42 / CE
- » Easy integration with Series MX FRLunits
- » Solutions to reach Performance Level E

The Machinery Directive (MD) 2006/42 / EC establishes the safety requirements that a machine must respect in order to protect the health of people during its use. Series MX SAFEMAX solenoid valves comply with ISO 13849-1, regarding the safe design of control systems that perform safety functions.

Series MX SAFEMAX solenoid valves are equipped with an integrated sensor that detects the position of the spool and enables to quickly exhaust the system in case of emergency. The single channel valve is classified in category 2 and can reach Performance level D. The double channel valve is classified in category 4 and can reach Performance level E. Please note: the safety valve is not sufficient, alone, to guarantee the safety function. Its setup requires the use of a monitoring device.

GENERAL DATA

Construction	modular, compact, spool-type
Materials	see TABLE OF MATERIALS on the following page
Ports	G1/2
Mounting	in-line, wall-mounting (by means of clamps)
Operating temperature	-5 ÷ +60 °C
Operating pressure	with internal servo-pilot: 3,5 bar ÷ 10 bar with external servo-pilot: 0,5 bar ÷ 10 bar (pilot 3,5 bar ÷ 10 bar, greater or equal to operating P)
Flow rate (6 bar)	single version: 1→2 = 5600 NL/min (ΔP 1) 2→3 = 5000 NL/min (free flow) double version: 1→2 = 4100 NL/min (ΔP 1) 2→3 = 5000 NL/min (free flow)
Medium	Filtered air in class 7.4.4 according to ISO 8573-1. In case lubricated air is used, we recommend ISOVG32 oil and to never interrupt lubrication.

COIL SPECIFICATIONS

Connection	DIN EN 175 301-803-B
Voltage	24V DC (±10%) 3,1W (ED 100%)

SENSOR SPECIFICATIONS

Connection	with wires, M8
Voltage	10-28V DC
Operation	Magneto-resistive
Type of contact	N.O. PNP
Max. current	EX version: 200 mA 0,65 W UL version: 100 mA 3 W CE version: 200 mA 5,5W

COMPLIANCE WITH EN ISO 13849-1 STANDARD

Performance level reachable (PL)	single version: category 2, PLd double version: category 4, PLe
B10d	2.000.000 cycles

CODING EXAMPLE SINGLE VALVE

MX	2	-	1/2	-	V	16	2	0	A	B	-	KK	-	LH
-----------	----------	----------	------------	----------	----------	-----------	----------	----------	----------	----------	----------	-----------	----------	-----------

MX	SERIES													
2	SIZE													
1/2	PORT 1/2 = G1/2													
V	COMPONENT V = 3/2-way valve													
16	CONSTRUCTION 16 = internal servo-pilot 17 = external servo-pilot													
2	CHANNEL 2 = single													
0	ACCESSORIES 0 = without silencer 1 = with silencer													
A	SENSOR A = UL sensor, 2 mt cable B = UL sensor, 5 mt cable C = ATEX sensor, 2 mt cable				D = ATEX sensor, 5 mt cable E = CE sensor M8 connector, 300 mm cable									
B	VERSION A = Atex B = UL C = CE sensor and version must comply with the same Standard / directive AB, BB - CA, DA - EC													
KK	MOUNTING = without mounting accessories HH = side quick clamps and flanges				JJ = side wall clamps and flanges KK = side wall brackets and flanges									
LH	FLOW DIRECTION = from left to right (standard) LH = from right to left													

SERIES MX SAFEMAX 3/2-WAY QUICK EXHAUST SAFETY VALVES

Symbols for single version

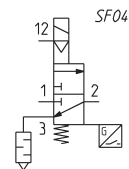
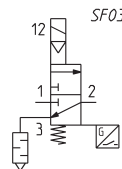
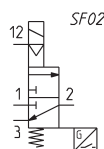
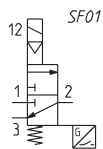

Series MX SAFEMAX single valve - materials

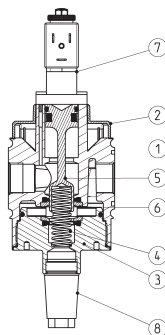

PARTS	MATERIALS
1 = Body	Aluminium
2 = Covering	Pom
3 = Cover	Aluminium
4 = Spring	Stainless steel
5 = Spool	Stainless steel, Fkm, Ptfe, Plastoferrite
6 = Cage element	Brass
7 = Solenoids	Copper, Brass, Stainless steel, PET
8 = Silencer	Stainless steel, Bronze
Seals	Nbr, Fkm
Sensor	Electric waste

Series MX SAFEMAX single valve - dimensions



The solenoid valve is supplied complete with sensor and coil

*connection available only with external pilot version

SERIES MX SAFEMAX 3/2-WAY QUICK EXHAUST SAFETY VALVES

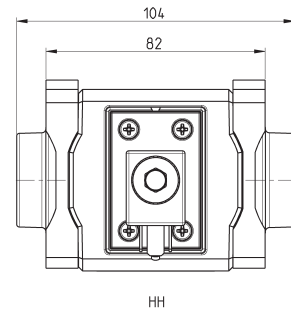
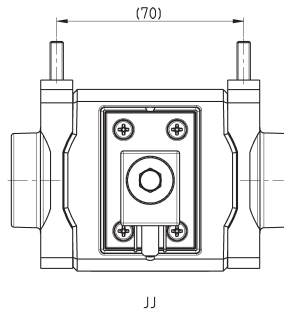
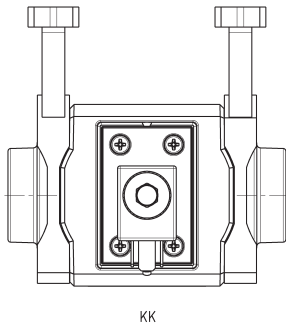
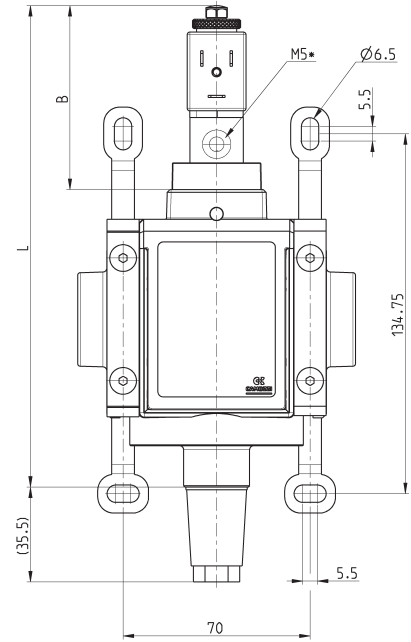
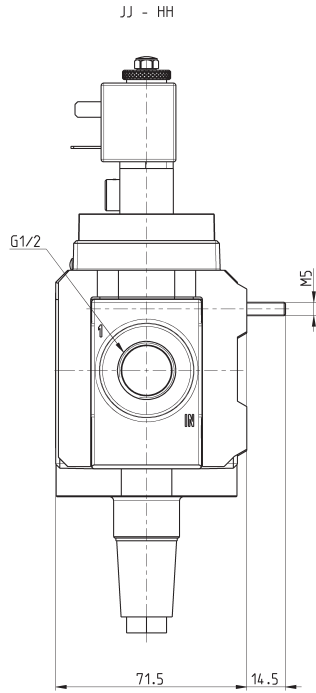
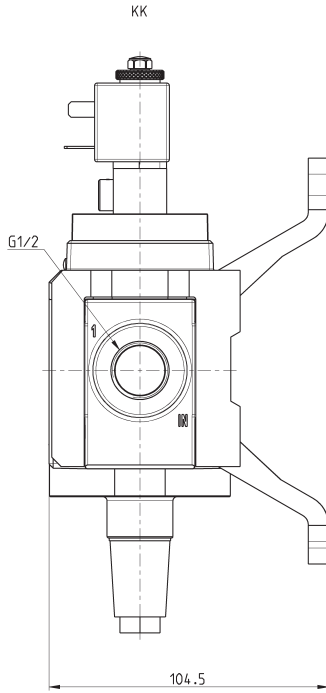

Mod.	L (mm)	B (mm)	Symbol
MX2-1/2-V162...	175	63	
MX2-1/2-V172...	180.5	69	

CODING EXAMPLE DOUBLE VALVE

MX	2	-	1/2	-	V	16	4	0	A	B	-	KK	-	LH
-----------	----------	----------	------------	----------	----------	-----------	----------	----------	----------	----------	----------	-----------	----------	-----------

MX	SERIES	
2	SIZE	
1/2	PORT 1/2 = G1/2	
V	COMPONENT V = 3/2-way valve	
16	CONSTRUCTION 16 = internal servo-pilot 17 = external servo-pilot	
4	CHANNEL 4 = double	
0	ACCESSORIES 0 = without silencer 1 = with silencer	
A	SENSOR A = UL sensor, 2 mt cable B = UL sensor, 5 mt cable C = ATEX sensor, 2 mt cable	D = ATEX sensor, 5 mt cable E = CE sensor M8 connector, 300 mm cable
B	VERSION A = Atex B = UL C = CE	sensor and version must comply with the same Standard / directive AB, BB - CA, DA - EC
KK	MOUNTING = without mounting accessories Z = central wall clamp Y = central wall bracket	HH = side quick clamps and flanges JJ = side wall clamps and flanges KK = side wall brackets and flanges
LH	FLOW DIRECTION = from left to right (standard) LH = from right to left	

SERIES MX SAFEMAX 3/2-WAY QUICK EXHAUST SAFETY VALVES

Symbols for double version

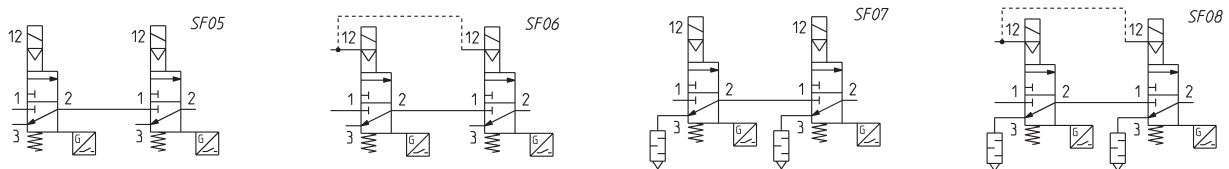

Series MX SAFEMAX double valve - materials

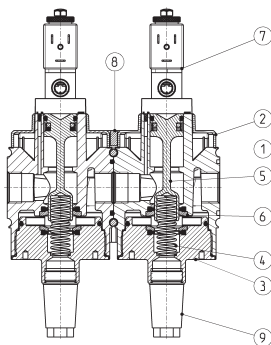

PARTS	MATERIALS
1 = Body	Aluminium
2 = Covering	Pom
3 = Cover	Aluminium
4 = Spring	Stainless steel
5 = Spool	Stainless steel, Fkm, Ptfе, Plastroferrite
6 = Cage element	Brass
7 = Solenoids	Copper, Brass, Stainless steel, PET
8 = Silencer	Stainless steel, Bronze
9 = Quick clamp	PA66
= O-Ring and seals	Nbr, Fkm
= Sensor	Electric waste

Series MX SAFEMAX double valve - dimensions



The solenoid valve is supplied complete with sensors and coils

*connection available only with external pilot version

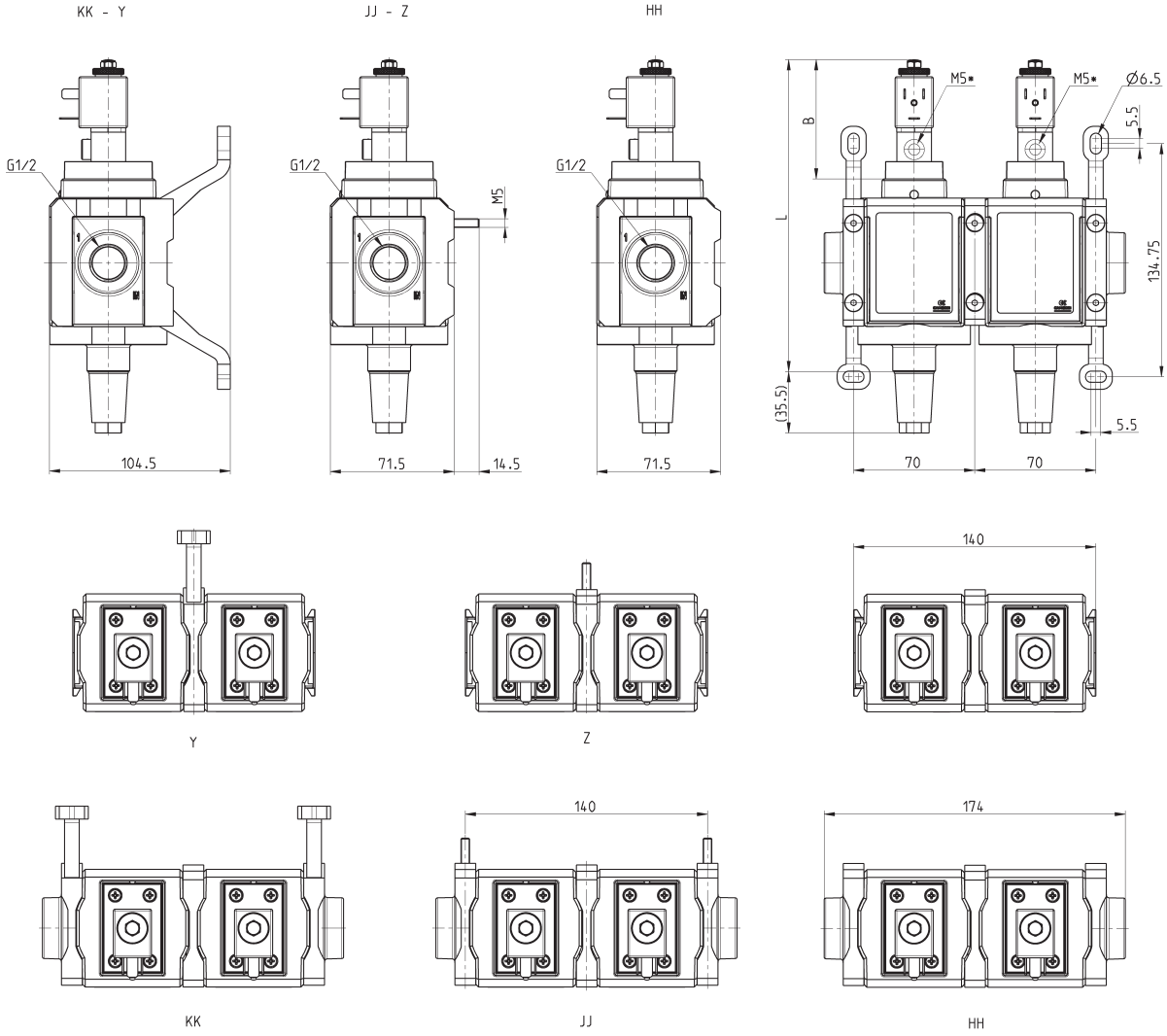

Mod.	L (mm)	B (mm)	Symbol
MX2-1/2-V164...	175	63	
MX2-1/2-V174...	180.5	69	



Series MX SAFEMAX 3/2-way quick exhaust safety valves with soft start

Ports: G1/2



- » According to Machinery Directive 2006/42 / CE
- » Easy integration with Series MX FRLunits
- » Different solutions up to Performance Level E
- » Integrated soft start valve
- » No interface plate for connections

The Machinery Directive (MD) 2006/42 / EC establishes the safety requirements that a machine must respect in order to protect the health of people during its use. Series MX SAFEMAX solenoid valves comply with ISO 13849-1, regarding the safe design of control systems that perform safety functions.

In this configuration, in addition to the characteristics of the versions with solenoid valves only, the soft start function has been integrated, which allows a gradual introduction of pressure into the system.

Its positioning upstream of the discharge valves allows, even in the event of an anomaly, to always have the maximum discharge flow rate. Thanks to the internal construction solutions it was possible to maintain the design and dimensions of the standard product, no further interface plates are necessary.

Please note: the safety valve alone is not sufficient to guarantee the safety function. Its activation requires the use of a supervisor device.

GENERAL DATA

Construction	modular, compact, spool-type
Materials	see TABLE OF MATERIALS on the following page
Ports	G1/2
Mounting	in-line, wall-mounting (by means of clamps)
Operating temperature	-5 ÷ +60 °C
Operating pressure	with internal servo-pilot: 3,5 bar ÷ 10 bar with external servo-pilot: 0,5 bar ÷ 10 bar (pilot 3,5 bar ÷ 10 bar, greater or equal to operating P)
Flow rate (6 bar)	single version: 1→2 = 4100 NL/min (ΔP 1) 2→3 = 5000 NL/min (free flow) double version: 1→2 = 3300 NL/min (ΔP 1) 2→3 = 5000 NL/min (free flow)
Medium	Filtered air in class 7.4.4 according to ISO 8573-1. In case lubricated air is used, we recommend ISOVG32 oil and to never interrupt lubrication.

COIL SPECIFICATIONS

Connection	DIN EN 175 301-803-B
Voltage	24V DC (±10%) 3,1W (ED 100%)

SENSOR SPECIFICATIONS

Connection	with wires, M8
Voltage	10-28V DC
Operation	Magneto-resistive
Type of contact	N.O. PNP
Max. current	EX version: 200 mA 0,65 W UL version: 100 mA 3 W CE version: 200 mA 5,5W

COMPLIANCE WITH EN ISO 13849-1 STANDARD

Performance level reachable (PL)	single version: category 2, PLd double version: category 4, Ple
B10d	2.000.000 cycles

CODING EXAMPLE SINGLE VALVE

MX	2	-	1/2	-	V	18	2	0	A	B	-	KK	-	LH
-----------	----------	----------	------------	----------	----------	-----------	----------	----------	----------	----------	----------	-----------	----------	-----------

MX	SERIES	
2	SIZE	
1/2	PORT 1/2 = G1/2	
V	COMPONENT V = 3/2-way valve	
18	CONSTRUCTION 18 = internal servo-pilot with soft start valve 19 = external servo-pilot with soft start valve	
2	CHANNEL 2 = single	
0	ACCESSORIES 0 = without silencer 1 = with silencer	
A	SENSOR A = UL sensor, 2 mt cable B = UL sensor, 5 mt cable C = ATEX sensor, 2 mt cable	D = ATEX sensor, 5 mt cable E = CE sensor M8 connector, 300 mm cable
B	VERSION A = Atex B = UL C = CE	sensor and version must comply with the same Standard / directive AB, BB - CA, DA - EC
KK	MOUNTING = without mounting accessories Z = central wall clamps Y = central wall brackets	HH = side quick clamps and flanges JJ = side wall clamps and flanges KK = side wall brackets and flanges
LH	FLOW DIRECTION = from left to right (standard) LH = from right to left	

SERIES MX SAFEMAX 3/2-WAY QUICK EXHAUST SAFETY VALVES + AVP

Symbols for single version with soft start valve

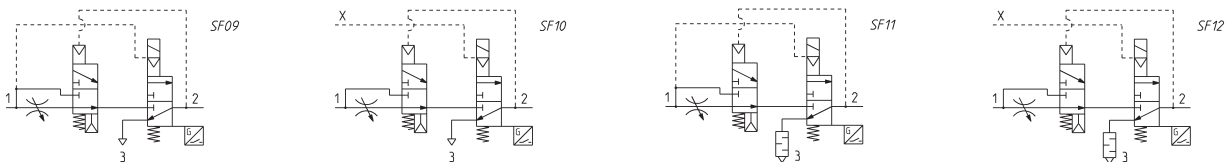

Series MX SAFEMAX single valve with soft start valve - materials

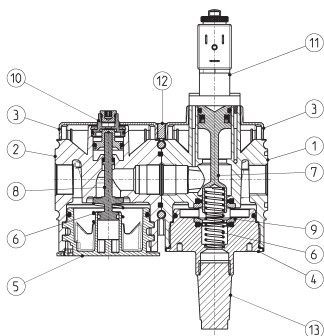

PARTS	MATERIALS
1 = Body of solenoid valve	Aluminium
2 = Body of starter	Aluminium
3 = Covering	Pom
4 = Valve cap	Aluminium
5 = Soft start valve cover	Pom
6 = Springs	Stainless steel
7 = Valve spool	Stainless steel, Fkm, Ptfе, plastoferrite
8 = Soft start valve spool	Brass
9 = Cage elements	Brass
10 = Upper cap of starter	Brass
11 = Solenoid	Copper, Brass, Stainless steel, PET
12 = Quick clamp	PA66
13 = Silencer and plugs	Stainless steel, Bronze
O-Ring and seals	Nbr, Fkm
Sensor	Sensor PA body, epoxy resin and PU cable

Series MX SAFEMAX single valve with soft start valve - dimensions

The solenoid valve is supplied complete with sensor and coil



*connection available only with external pilot version

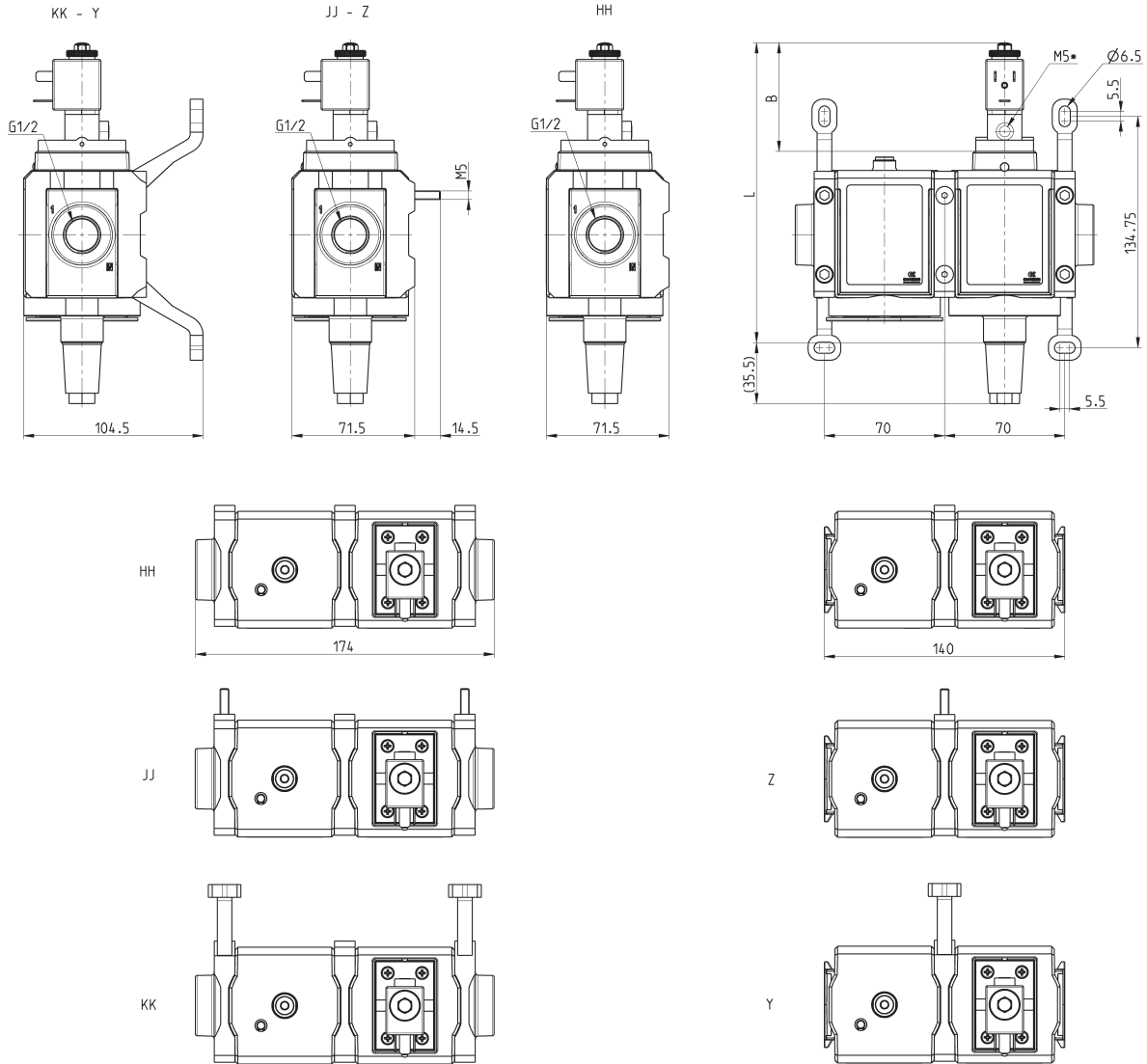

Mod.	L (mm)	B (mm)	Symbol
MX2-1/2-V182...	175	63	SF09 - SF11
MX2-1/2-V192...	180.5	69	SF10 - SF12

CODING EXAMPLE DOUBLE VALVE

MX	2	-	1/2	-	V	18	4	0	A	B	-	KK	-	LH
-----------	----------	----------	------------	----------	----------	-----------	----------	----------	----------	----------	----------	-----------	----------	-----------

MX	SERIES	
2	SIZE	
1/2	PORT 1/2 = G1/2	
V	COMPONENT V = 3/2-way valve	
18	CONSTRUCTION 18 = internal servo-pilot with soft start valve 19 = external servo-pilot with soft start valve	
4	CHANNEL 4 = double	
0	ACCESSORIES 0 = without silencer 1 = with silencer	
A	SENSOR A = UL sensor, 2 mt cable B = UL sensor, 5 mt cable C = ATEX sensor, 2 mt cable	D = ATEX sensor, 5 mt cable E = CE sensor M8 connector, 300 mm cable
B	VERSION A = Atex B = UL C = CE	sensor and version must comply with the same Standard / directive AB, BB - CA, DA - EC
KK	MOUNTING = without mounting accessories Z = central wall clamps Y = central wall brackets	HH = side quick clamps and flanges JJ = side wall clamps and flanges KK = side wall brackets and flanges
LH	FLOW DIRECTION = from left to right (standard) LH = from right to left	

SERIES MX SAFEMAX 3/2-WAY QUICK EXHAUST SAFETY VALVES + AVP

Symbols for double version with soft start valve

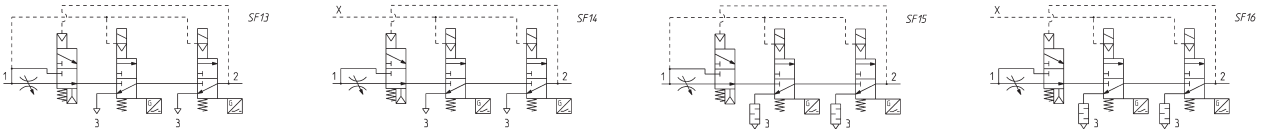

Series MX SAFEMAX double valve with soft start valve - materials

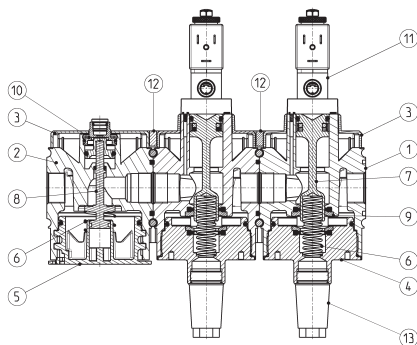

PARTS	MATERIALS
1 = Body of solenoid valve	Aluminium
2 = Body of starter	Aluminium
3 = Covering	Pom
4 = Valve cap	Aluminium
5 = Soft start valve cover	Pom
6 = Springs	Stainless steel
7 = Valve spool	Stainless steel, Fkm, Ptfе, plastoferrite
8 = Soft start valve spool	Brass
9 = Cage elements	Brass
10 = Upper cap of starter	Brass
11 = Solenoid	Copper, Brass, Stainless steel, PET
12 = Quick clamp	PA66
13 = silencer and plugs	Stainless steel, Bronze
O-Ring and seals	Nbr, Fkm
Sensor	Sensor PA body, epoxy resin and PU cable

Series MX SAFEMAX double valve with soft start valve - dimensions

The solenoid valve is supplied complete with sensors and coils



*connection available only with external pilot version

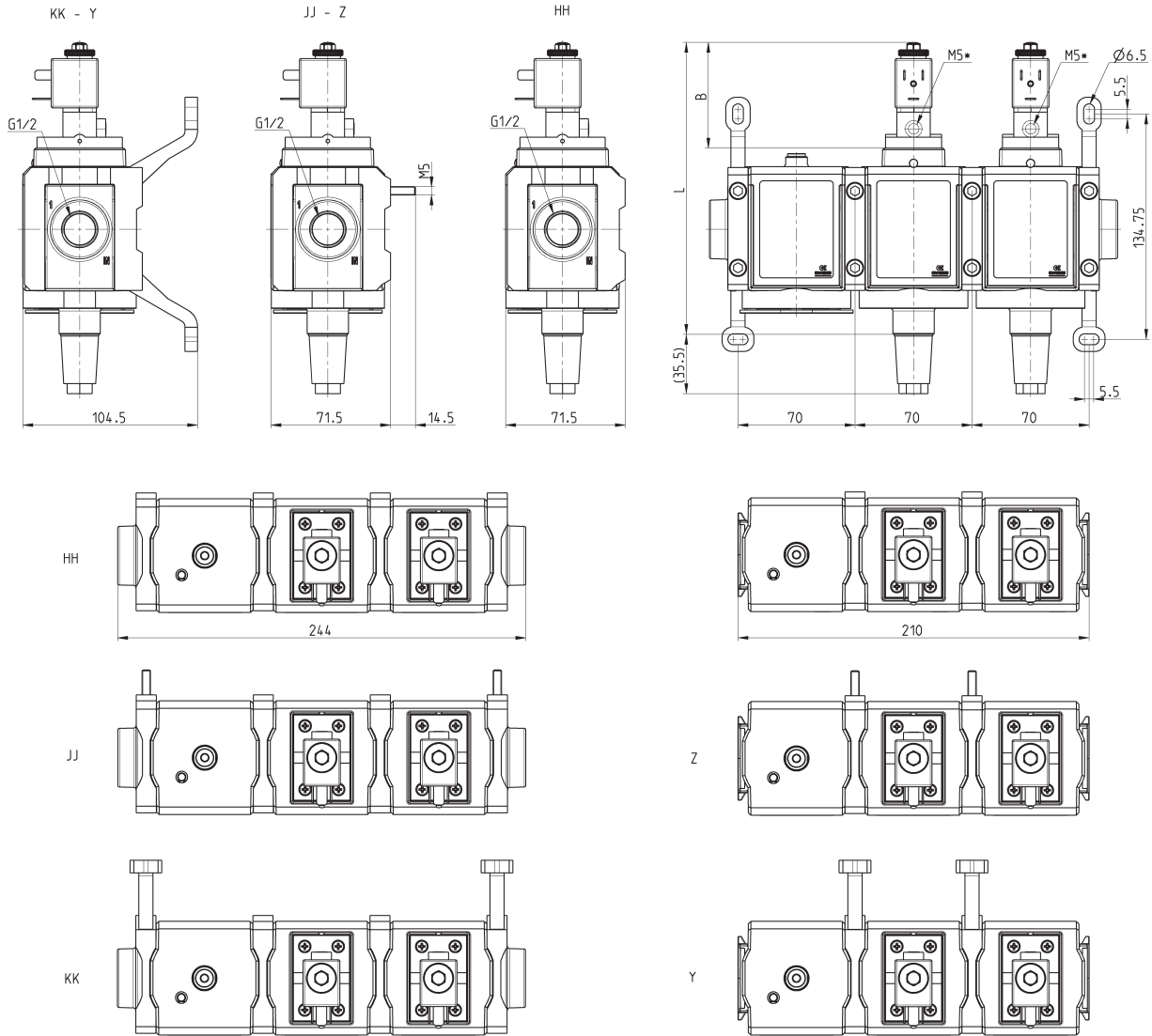

Mod.	L (mm)	B (mm)	Symbol
MX2-1/2-V184...	175	63	SF13 - SF15
MX2-1/2-V194...	180.5	69	SF14 - SF16

Series MX soft start valves

MX2 ports: G3/8, G1/2, G3/4 - MX3 ports: G3/4, G1
Modular



- » Opening of the main air path at about 50% of the value of the inlet pressure
- » Pressure switches available on request

These soft start valves allow a gradual increase of the pressure in pneumatic systems. The pressure increases slowly according to the set regulation until it reaches half of the set value, then it increases rapidly. The valve poppet shifts slowly and securely to the open position to prevent sudden and unsafe movements of the pneumatic components in the system.

The Series MX has been realized to offer a multi-sector solution that guarantees saving in terms of installation time, space and costs.

A special configurator, available on Camozzi website at <http://catalogue.camozzi.com> (sec. Configurators), allows the customer to choose the most suitable solution for his application, selecting single components or by configuring assembled FRLs.

GENERAL DATA

Construction	modular, compact, poppet-type
Materials	see TABLE OF MATERIALS on the following page
Ports	MX2: G3/8 - G1/2 - G3/4 MX3: G3/4 - G1
Mounting	in-line wall-mounting (by means of clamps)
Operating temperature	-5°C ÷ 50°C up to 16 bar (with the dew point of the fluid lower than 2°C at the min. working temperature) -5°C ÷ 60°C up to 10 bar (with the dew point of the fluid lower than 2°C at the min. working temperature)
Operating pressure	2 ÷ 16 bar
Nominal flow (at 6 bar with ΔP 1 bar)	MX2: 5800 NL/min (G1/2, G3/4) MX2: 4500 NL/min (G3/8) MX3: 8500 NL/min
Fluid	compressed air

CODING EXAMPLE

MX	2	-	3/8	-	AV	-	LH
MX	SERIES						
2	SIZE: 2 = G3/8 - G1/2 - G3/4 3 = G3/4 - G1						
3/8	PORT: 3/8 = G3/8 1/2 = G1/2 3/4 = G3/4 1 = G1						
AV	SOFT START VALVE						
LH	FLOW DIRECTION: = from left to right (standard) LH = from right to left						

For the assembly of a single component with fixing flanges or wall-mounting, see the section "FRL Series MX Assembled"

Soft start valves Series MX - materials

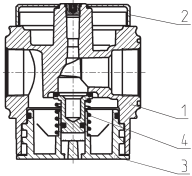

PARTS	MATERIALS
1 = Body	Aluminium
2 = Covering	Polyacetal
3 = Valve holder plug	Polyacetal
4 = Lower spring	Stainless steel
Seals	NBR

MX2 DIAGRAMS FOR PRESSURISATION TIMES

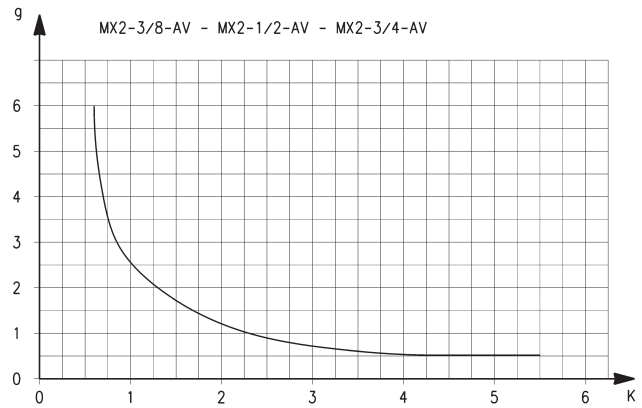
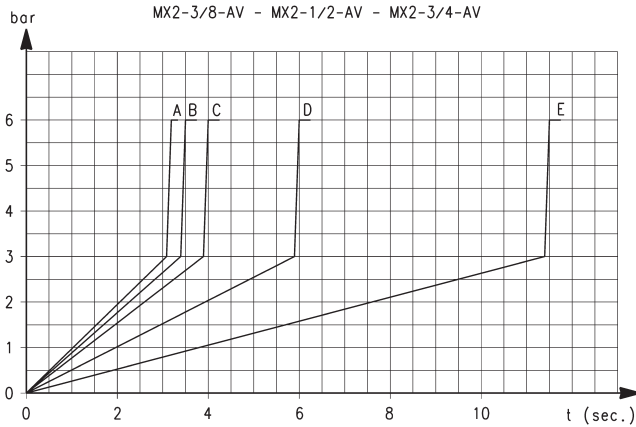

Pressurisation times as to the number of turns of the regulation screw, with downstream volume of 5 litres. A = 5 turns - B = 4 turns - C = 3 turns - D = 2 turns - E = 1 turn. K = number of turns of the regulation screw required to obtain the required pressurisation time with an inlet pressure of 6 bar. Variations of the inlet pressure can cause deviations of the pressure time by ± 20%. $K = t/V$ where: V = volume of the downstream system in litres; t = desired pressuring time in seconds.

EXAMPLE:
V = 5 litres
t = 16 seconds
 $K = 16/5 = 3,2$

Using in the graph this value K, the number of turns of the regulation screw will be approx. 0,8.

MX3 DIAGRAMS FOR PRESSURISATION TIMES

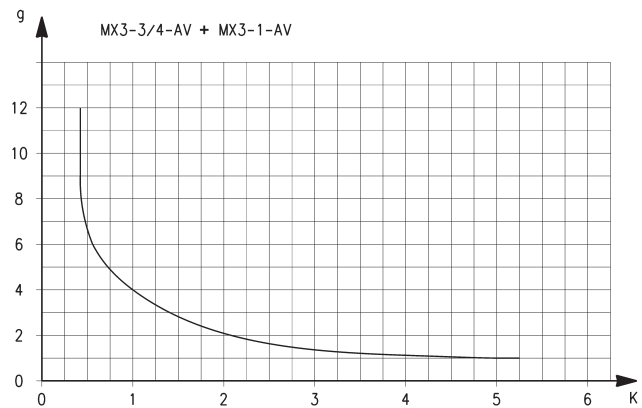
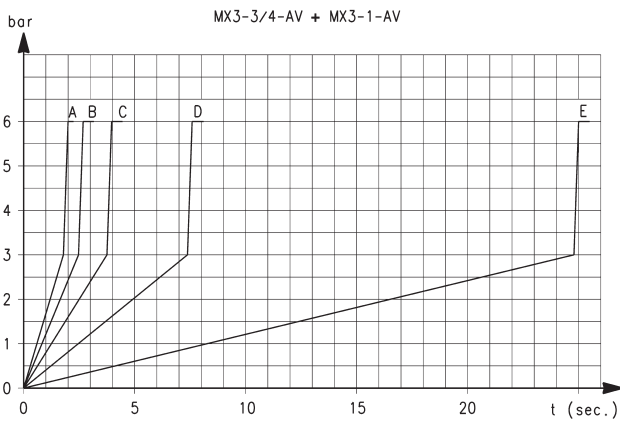

Pressurisation times as to the number of turns of the regulation screw, with downstream volume of 5 litres. A = 5 turns - B = 4 turns - C = 3 turns - D = 2 turns - E = 1 turn. K = number of turns of the regulation screw required to obtain the required pressurisation time with an inlet pressure of 6 bar. Variations of the inlet pressure can cause deviations of the pressure time by ± 20%. $K = t/V$ where: V = volume of the downstream system in litres; t = desired pressuring time in seconds.

EXAMPLE:
V = 5 litres
t = 16 seconds
 $K = 16/5 = 3,2$

Using in the graph this value K, the number of turns of the regulation screw will be approx. 1,8.

Soft start valves Series MX - dimensions

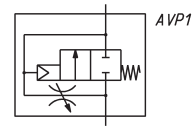
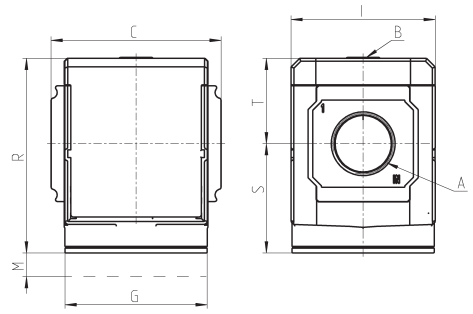

Mod.	A	B	C	G	I	M	R	S	T	Weight (kg)
MX2-3/8-AV	G3/8	G1/8	70	65	68	46,5	88	50,5	37,5	0.4
MX2-1/2-AV	G1/2	G1/8	70	65	68	46,5	88	50,5	37,5	0.4
MX2-3/4-AV	G3/4	G1/8	70	65	68	46,5	88	50,5	37,5	0.4
MX3-3/4-AV	G3/4	G1/8	89,5	75	76	48	102	57,5	44,5	0.7
MX3-1-AV	G1	G1/8	89,5	75	76	48	102	57,5	44,5	0.7

AVP1 = soft start valve

Series MX take-off blocks

MX2 port: G1/2 - MX3 port: G1
Modular



- » Compact design
- » Available with or without VNR (no return valve)
- » Pressure switches available on request

The Take-off blocks, when equipped with a no return valve, can be used to bleed non lubricated air.

The Series MX has been realized to offer a multi-sector solution that guarantees saving in terms of installation time, space and costs.

A special configurator, available on Camozzi website at <http://catalogue.camozzi.com> (sec. Configurators), allows the customer to choose the most suitable solution for his application, selecting single components or by configuring assembled FRLs.

GENERAL DATA

Construction	modular, compact, diaphragm-type
Materials	see TABLE OF MATERIALS on the following page
Ports	MX2: G1/2 MX3: G1
Take-off ports	MX2: G1/2 MX3: G1
Mounting	in-line wall-mounting (by means of clamps)
Operating temperature	-5°C ÷ 50°C up to 16 bar (with the dew point of the fluid lower than 2°C at the min. working temperature) -5°C ÷ 60°C up to 10 bar (with the dew point of the fluid lower than 2°C at the min. working temperature)
Operating pressure	0 ÷ 16 bar
Nominal flow at 6 bar with Δp = 1 bar	MX2-1/2-B00 = 6800 NI/min MX2-1/2-B01 = 5700 NI/min MX3-1-B00 = 14500 NI/min MX3-1-B01 = 10500 NI/min
Fluid	compressed air

CODING EXAMPLE

MX	2	-	1/2	-	B	00	-	LH
-----------	----------	----------	------------	----------	----------	-----------	----------	-----------

MX	SERIES
2	SIZE: 2 = G1/2 3 = G1
1/2	PORT: 2 = G1/2 3 = G1
B	TAKE-OFF BLOCK
00	DESIGN TYPE: 00 = without no return valve (standard) 01 = with no return valve 02 = without no return valve, with double O-ring seat
LH	FLOW DIRECTION: = from left to right (standard) LH = from right to left

SERIES MX TAKE-OFF BLOCKS

For the assembly of a single component with fixing flanges or wall-mounting, see the section "FRL Series MX Assembled"

Take-off blocks Series MX - materials

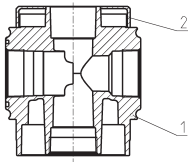

PARTS	MATERIALS
1 = Body	Aluminium
2 = Covering	Polyacetal
Seals	NBR

Series MX take-off blocks - dimensions



TABLE NOTE:
* to complete the code see
the CODING EXAMPLE

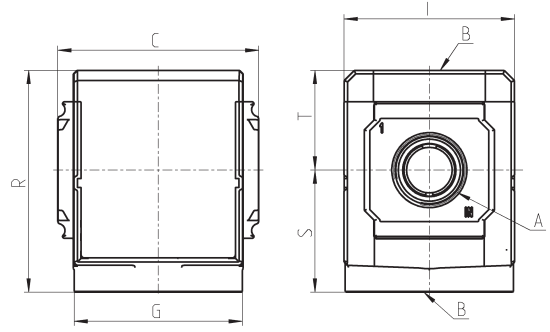

BL01 = take-off block



BL02 = take-off block with VNR

Mod.	A	B	C	G	I	R	S	T	Weight (Kg)
MX2-1/2-B*	G1/2	G1/2	70	65	68	86	47,5	38,5	0.4
MX3-1-B*	G1	G1	89,5	75	76	99	54,5	44,5	0.6

Use of the take-off block MX...- B02

The take-off block with double O-ring seat is particularly suitable when Series MX modules have to be supplied through the same pressure source. The modules which are connected to the left side are of LH kind.

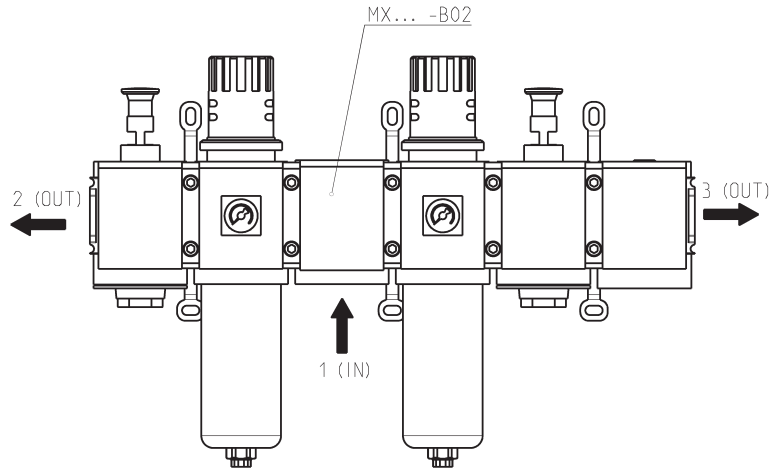

ACCESSORIES FOR SERIES MX



Rapid clamps



Rapid clamps with brackets



Terminal flanges (IN/OUT)



Fixing brackets for regulators



Block for pressure gauge fixing



Assembly O-ring



MX built-in pressure gauge



Fixing brackets for regulators

ACCESSORIES FOR SERIES MX



Systems of rapid connections designed to make mounting easier.

Rapid clamp kit Mod. MX2-... and MX3...



The kit MX2-X is supplied with:
1 rapid clamp, 1 O-ring OR 3125 *,
2 exagonal nuts M5, 2 screws M5x69.

The kit MX2-Z is supplied with:
1 rapid clamp, 1 O-ring OR 3125 *,
1 exagonal nut M5, 1 screw M5x69,
1 screw M5x85 for wall fixing.

* it can be ordered separately (cod. 160-39-11/19)

The kit MX3-X is supplied with:
1 rapid clamp, 1 O-ring OR 38X2,8 **,
2 square nuts M6, 2 screws M6x75.

The kit MX3-Z is supplied with:
1 rapid clamp, 1 O-ring OR 38X2,8 **,
1 square nut M6, 1 screw M6x75,
1 screw M6x90 for wall fixing.

** it can be ordered separately (OR 38X2,8 NBR)

Materials: technopolymer clamp, NBR O-ring, zinc-plated steel nuts and screws.

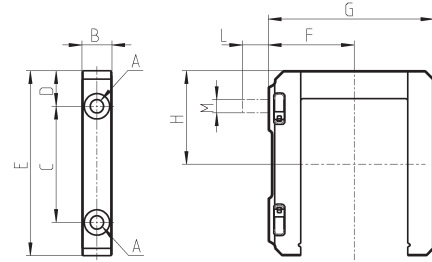

See the positioning scheme in the section "Series MX assembled FRL"

DIMENSIONS

Mod.	A	B	C	D	E	F	G	H	L	M	Notes
MX2-X	5.2	12	46	14	73.5	37.5	70.5	37	-	-	
MX2-Z	5.2	12	46	14	73.5	37.5	70.5	37	14	M5	kit with wall fixing screw
MX3-X	6.2	14	54	16.5	86	40	77	43.5	-	-	
MX3-Z	6.2	14	54	16.5	86	40	77	43.5	13	M6	kit with wall fixing screw

Rapid clamp kit with wall fixing brackets - size 2



The kit MX2-Y is supplied with:
1 wall rapid clamp, 1 O-ring OR 3125 **, 2 exagonal nuts, 2 screws M5x69.

** it can be separately ordered (cod. 160-39-11/19)

Materials: technopolymer clamp, NBR O-ring, zinc-plated steel nuts and screws.

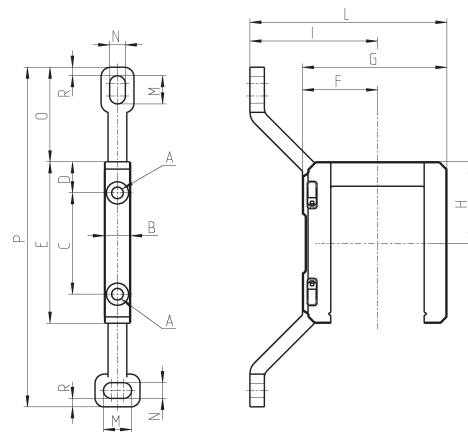

Mod.	A	B	C	D	E	F	G	H	I	L	M	N	O	P	R
MX2-Y	5,2	12	46	14	73,5	32,5	70,5	37	70,5	103	12	6,5	42	152	4

See the positioning scheme in the section "Series MX assembled FRL"

Rapid clamp kit with wall fixing brackets - size 3



The kit MX3-Y is supplied with:
 1 wall rapid clamp, 1 O-ring 38X2,8 **,
 2 square nuts M6, 2 screws M6x75

** it can be also separately ordered (OR 38X2,8 NBR)

Materials: technopolymer clamp, NBR O-ring, zinc-plated steel nuts and screws.

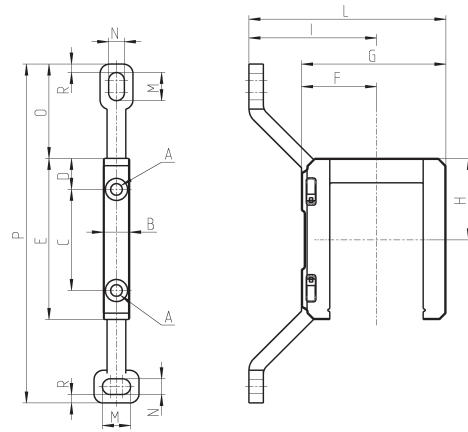

See the positioning scheme in the section "Series MX assembled FRL"

Mod.	A	B	C	D	E	F	G	H	I	L	M	N	O	P	R
MX3-Y	6,2	14	54	16,5	86	40	77	43,5	68	105	15	8,4	50,5	181	4,5

Terminal flanges (IN/OUT)

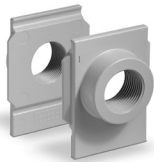

The kit is supplied with:
 - 1 flange INLET side
 - 1 flange OUTLET side

Materials: painted aluminium flanges.

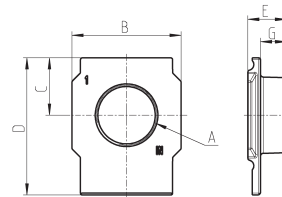

Mod.	A	B	C	D	E	G
MX2-3/8-FL	G3/8	50	26,5	63,5	17	11
MX2-1/2-FL	G1/2	50	26,5	63,5	17	11
MX2-3/4-FL	G3/4	50	26,5	63,5	17	11
MX3-3/4-FL	G3/4	58	30,5	73	20,5	13,5
MX3-1-FL	G1	58	30,5	73	20,5	13,5

Fixing bracket for regulators



The kit is supplied with 1 zinc-plated steel bracket

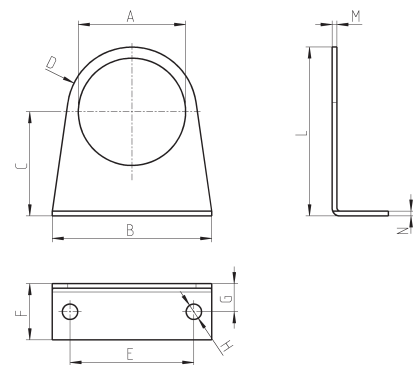

Mod.	A	B	C	D	E	F	G	H	L	M	N
MX3-S	∅ 57,2	85	55,5	R34,5	66	30	15	∅ 8,2	90	2,5	2,5

Fixing bracket for regulators



The kit is supplied with 1 zinc-plated steel bracket

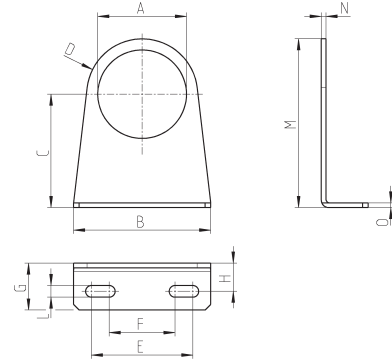

DIMENSIONS												
Mod.	A	B	C	D	E	F	G	H	L	M	N	O
MX2-S	Ø47.2	73	60.5	R29.5	54	35	25	15	6.2	90	2.5	2.5
MX2-S2	Ø47.2	73	40	R29.5	54	35	25	15	6.2	90	2.5	2.5

Rapid clamps kit + flanges



Mod.	The kit is supplied with:
MX2-3/8-HH	1x MX2-3/8-FL + 2x MX2-X
MX2-1/2-HH	1x MX2-1/2-FL + 2x MX2-X
MX2-3/4-HH	1x MX2-3/4-FL + 2x MX2-X
MX2-3/8-JJ	1x MX2-3/8-FL + 2x MX2-Z
MX2-1/2-JJ	1x MX2-1/2-FL + 2x MX2-Z
MX2-3/4-JJ	1x MX2-3/4-FL + 2x MX2-Z
MX3-3/4-HH	1x MX3-3/4-FL + 2x MX3-X
MX3-1-HH	1x MX3-1-FL + 2x MX3-X
MX3-3/4-JJ	1x MX3-3/4-FL + 2x MX3-Z
MX3-1-JJ	1x MX3-1-FL + 2x MX3-Z

Rapid clamps kit with wall fixing brackets + flanges



Mod.	The kit is supplied with:
MX2-3/8-KK	1x MX2-3/8-FL + 2x MX2-Y
MX2-1/2-KK	1x MX2-1/2-FL + 2x MX2-Y
MX2-3/4-KK	1x MX2-3/4-FL + 2x MX2-Y
MX3-3/4-KK	1x MX3-3/4-FL + 2x MX3-Y
MX3-1-KK	1x MX3-1-FL + 2x MX3-Y

Block for pressure gauge fixing



The kit is supplied with:
 1 block
 1 grain
 2 screws
 1 seal

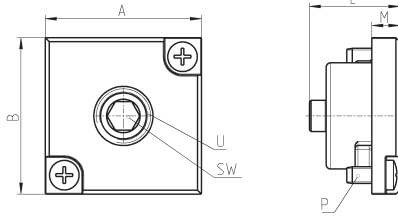

DIMENSIONS							
Mod.	A	B	L	M	P	U	SW
MX2-R26/1-P	28	28	16.5	5	M3X7	1/8	5
MX3-R26/1-P	28	28	16.5	5	M3X7	1/4	6

MX built-in pressure gauge



The kit is supplied with:
 1 pressure gauge
 1 seal
 2 screws

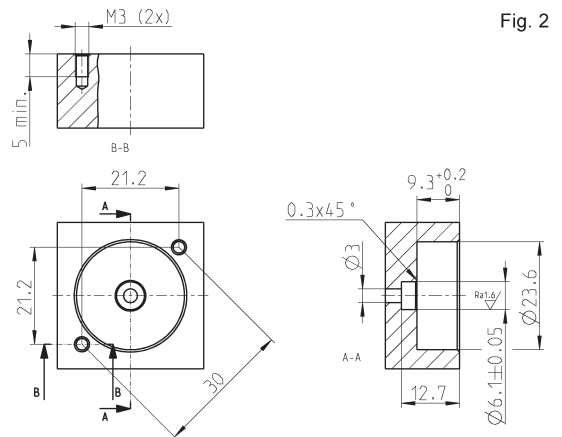
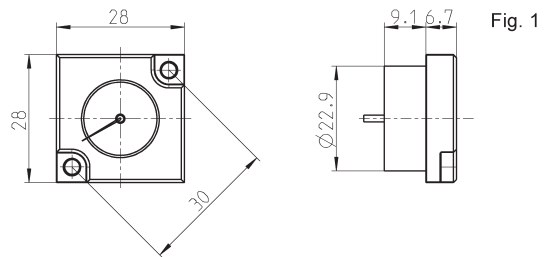

Mod.	Range
MX3-R31/W-P	0 ÷ 6 bar
MX3-R32/W-P	0 ÷ 10 bar
MX3-R30/W-P	0 ÷ 12 bar

Fig. 1 = pressure gauge
 Fig. 2 = seat

O-ring for assembling

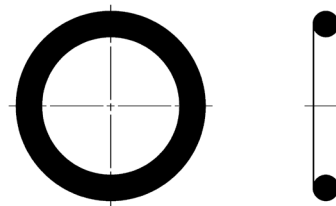

Mod.	O-ring	For assembly
160-39-11/19	OR 3125	MX2
OR 38X2,8 NBR	OR 38X2,8	MX3

Series MX assembled FRL

MX2 ports: G3/8, G1/2, G3/4 - MX3 ports: G3/4, G1
Assembly through rapid clamps

SERIES MX ASSEMBLED FRL

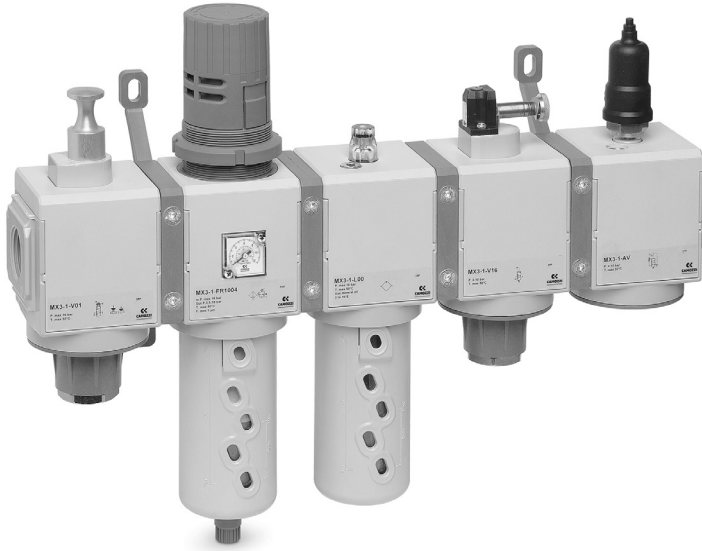

- » Compact design
- » Dimensions optimization
- » Great reliability
- » Easy and quick maintenance
- » Reduced weight

Series MX FRL can be easily assembled through rapid clamps which allow the connection among single components creating an unlimited number of compositions. The FRL groups Series MX are also available in the already mounted version (with a single code).

The use of three different types of rapid clamps (standard, with wall fixing screws or with brackets) allows an easy mounting of the assembled groups and to carry out maintenance operations on the single components with no need to disassemble the group.

GENERAL DATA

Construction	modular, compact
Materials	see catalogue pages referring to the single component
Ports	MX2: G3/8 - G1/2 - G3/4 MX3: G3/4 - G1
Mounting	vertical in-line wall-mounting (by means of clamps) panel mounting
Operating temperature	-5°C ÷ 50°C up to 16 bar (according to the single component characteristics) -5°C ÷ 60°C up to 10 bar (according to the single component characteristics)

CONFIGURATION OF ASSEMBLED GROUPS SERIES MX

TO CONFIGURE THE ASSEMBLED GROUPS SERIES MX, USE THE HERE BELOW EXAMPLE AND THE RELATED LEGEND ON THE FOLLOWING PAGE.

Configuration of the assembled group in the drawing below:

MX2-3/8-V01+A32XF00XR004YL00XV16-KK

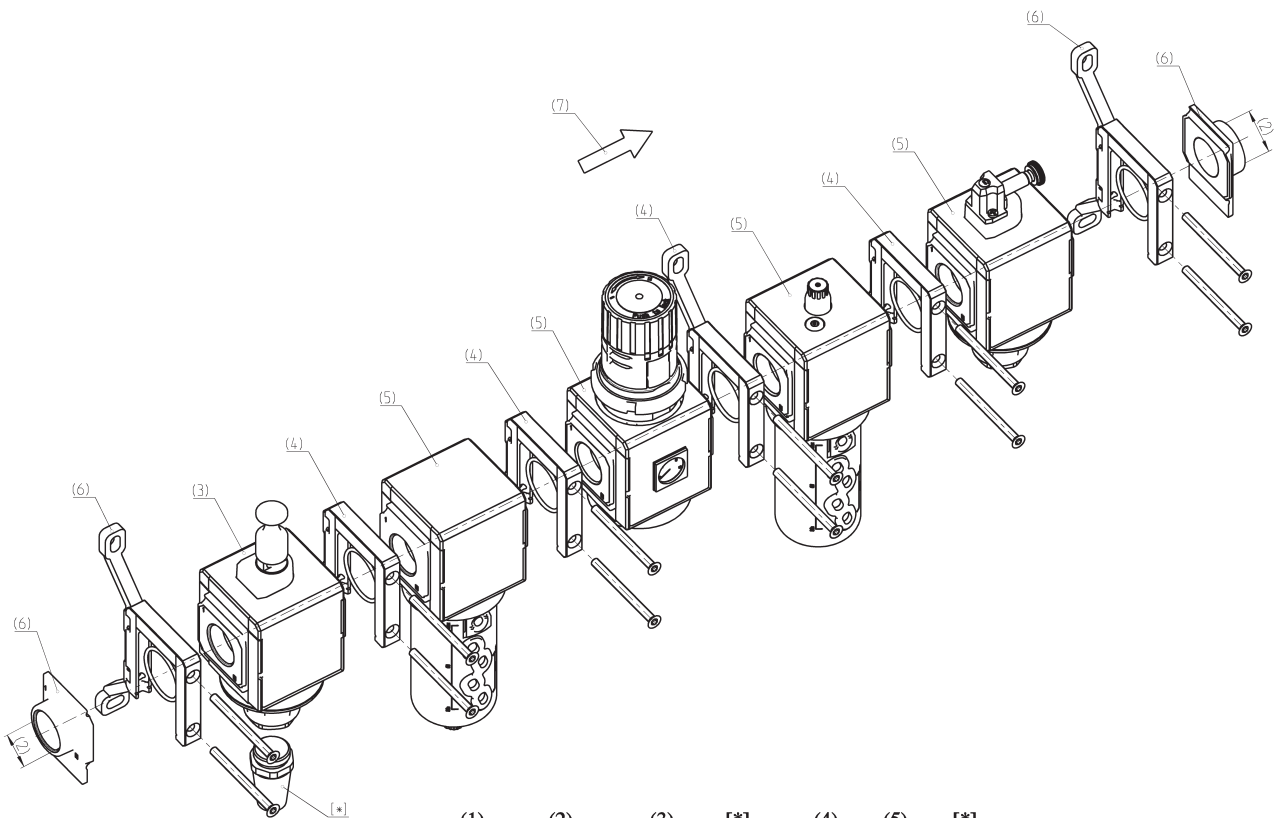

	(1)	(2)	(3)	[*]	(4)	(5)	[*]
MX	2	3/8	V01	+A32	X	F00	

n_x

X	R004
Y	L00

X	V16	(6)	[*]	(7)
		KK		

CONFIGURATOR OF ASSEMBLED GROUPS SERIES MX

MX	2	-	3/8	-	V01	X	F00	-	KK	-	LH
-----------	----------	----------	------------	----------	------------	----------	------------	----------	-----------	----------	-----------

MX		SERIES
2	(1)	SIZE: 2 = G3/8 - G1/2 - G3/4 3 = G3/4 - G1
-		
3/8	(2)	IN / OUT THREADS: 3/8 = G3/8 1/2 = G1/2 3/4 = G3/4 1 = G1
-		
V01	(3)	MODULE + [*] (to configure the modules, see the single components pages): F... = Filter FC... = Coalescing filter FCA... = Activated carbons filter R... = Pressure regulator L... = Lubricator FR... = Filter-Regulator V... = Lockable isolation valve AV... = Soft start valve B... = Take-off block (MX2: G1/2 only - MX3: G1 only)
	[*]	The following ACCESSORIES can be added after every single module: REGULATOR AND FILTER-REGULATOR MX2 +A56 = M053-P06 (Pressure gauge) +A57 = M053-P10 (Pressure gauge) +A58 = M063-P12 (Pressure gauge) LOCKABLE ISOLATION VALVE MX2 +A30 = 2901 1/2" (Silencier) +A31 = 2921 1/2" (Silencier) +A32 = 2931 1/2" (Silencier) +A33 = 2938 1/2" (Silencier) SOFT START VALVE +A00 = PM11-NA (Pressure switch, normally open) +A01 = PM11-NC (Pressure switch, normally closed) TAKE-OFF BLOCK MX2 +A08 = PM11-NA (normally open pressure switch) with fitting for fixing to the module +A09 = PM11-NC (normally closed pressure switch) with fitting for fixing to the module +A03 = PM11-SC with fitting for fixing to the module Example: MX2-3/8-V01+A32XF00-KK-LH
		REGULATOR AND FILTER-REGULATOR MX3 +A60 = M063-P06 (Pressure gauge) +A61 = M063-P12 (Pressure gauge) LOCKABLE ISOLATION VALVE MX3 +A34 = 2901 3/4" (Silencier) +A35 = 2921 3/4" (Silencier) +A36 = 2931 3/4" (Silencier) TAKE-OFF BLOCK MX3 +A06 = PM11-NA (normally open pressure switch) with fitting for fixing to the module +A07 = PM11-NC (normally closed pressure switch) with fitting for fixing to the module +A02 = PM11-SC with fitting for fixing to the module Example: MX3-3/4-V01+A36XF00-KK-LH
X	(4)	MODULES CONNECTION (according to the positioning scheme on the following page): X = Rapid clamp kit Z = Rapid clamp kit with wall fixing screw Y = Rapid clamp kit with wall fixing brackets
F00	(5) + [*]	see MODULE (3)
-		
KK	(6)	TERMINAL CONNECTIONS + [**] (according to the positioning scheme on the following page): = no terminal connection HH = n° 1 rapid clamp kit with flanges (IN / OUT) JJ = n° 1 rapid clamp kit with wall fixing screws + flanges (IN / OUT) KK = n° 1 rapid clamp kit with wall fixing brackets + flanges (IN / OUT)
	[**]	WALL CONNECTION: REGULATOR and FILTER-REGULATOR S = Bracket (only with clamps mod. X o HH) Codes examples: MX3-1-R..XV..-S; MX3-1-R..XV..-HSH
-		
LH	(7)	FLOW DIRECTION: = from left to right (standard) LH = from right to left
	(4) + (5) + [*]	REPEATABLE COMBINATION for a "n" number of times

SERIES MX ASSEMBLED FRL

Wall fixing - mounting dimensions and positioning scheme

Legend of the POSITIONING SCHEME:

- 1 = rapid clamp with wall fixing screw
or with wall fixing bracket
- 2 = module / flange

* POSITIONING SCHEME referring to drawings "Y" and "Z".

Legend of the ASSEMBLED GROUPS DRAWINGS:

- "Y" = with rapid clamps with wall fixing brackets (MX...-Y)
- "Z" = with rapid clamp with wall fixing screws (MX...-Z)
- G = fixing point

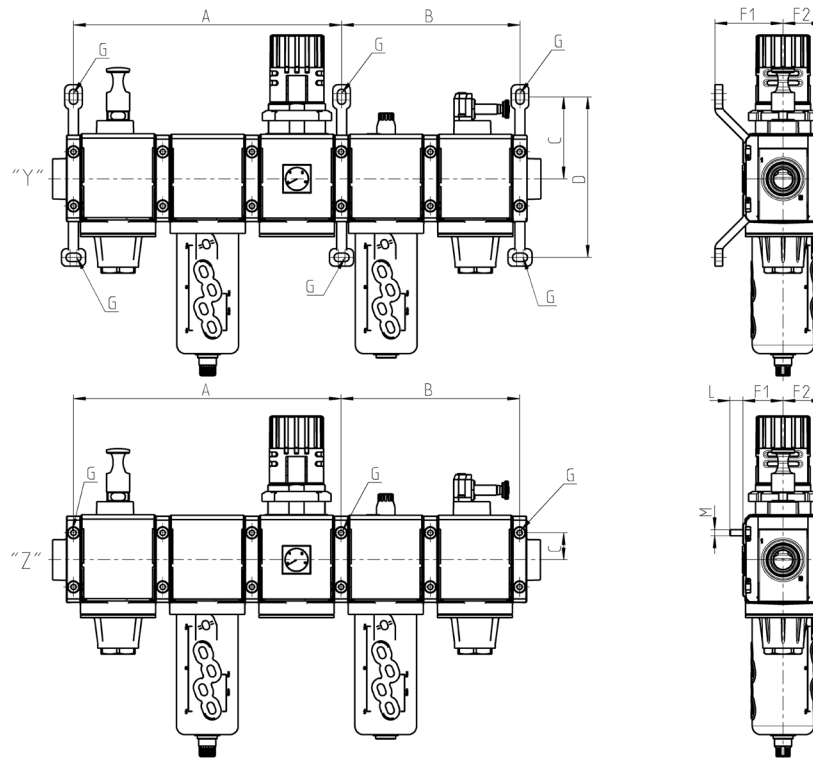
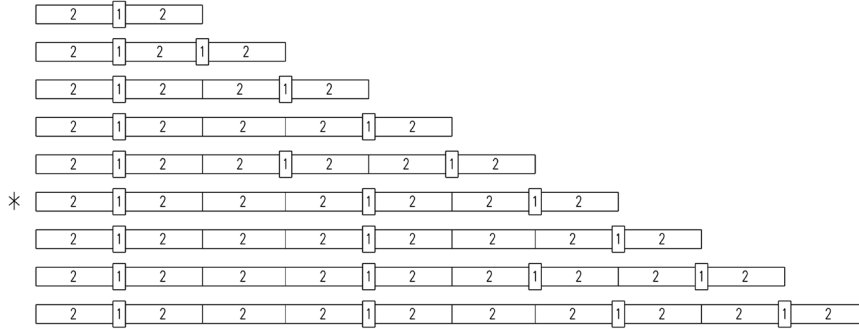

Mod.	A	B	C	D	F1	F2	L	M
MX2-Y	210	140	68,5	134,5	70	37	-	-
MX2-Z	210	140	23	-	37,5	37	13,5	M5
MX3-Y	267	178	82	160	68	40,5	-	-
MX3-Z	267	178	27	-	40,5	40,5	13	M6

CODING EXAMPLE

MX	2	-	3/8	-	0...1
-----------	----------	----------	------------	----------	--------------

MX	SERIES
2	SIZE: 2 = G3/8 - G1/2 - G3/4 3 = G3/4 - G1
3/8	PORTS: 3/8 = G3/8 1/2 = G1/2 3/4 = G3/4 1 = G1
000001	GROUP COMPOSITION: 000001 = F10 + R004 + L00 000002 = FR1004 + L00 000003 = V01 + FR1004 + L00 000004 = V01 + FR1004 000005 = FR1004 + V16 + AV 000006 = FR1004 + L00 + V16 + AV 000007 = V01 + FR1004 + V16 + AV 000008 = V01 + FR1004 + L00 + V16 + AV + PRESS. NO 000009 = V01 + FR1004 + L00 + V16 + AV + PRESS. NC 000010 = V01 + FR1004 + V16 + AV + PRESS. NO 000011 = V01 + FR1004 + V16 + AV + PRESS. NC 000012 = F13 + FC03
	WARNING: IN THE PRESENCE OF METAL PIPES, THE USE OF CONNECTION FLANGES MAKE THE MAINTENANCE ACTIVITIES EASIER. INITIALLY PROCEED BY ASSEMBLING THE PIPES ON THE FLANGES, THEN FIX THE TREATMENT UNIT TO THE WALL THROUGH THE PROPER FIXING BRACKETS.

SERIES MX ASSEMBLED FRL

Composition of the assembled group 000001



Components:
Filter
Regulator
Lubricator

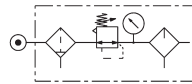
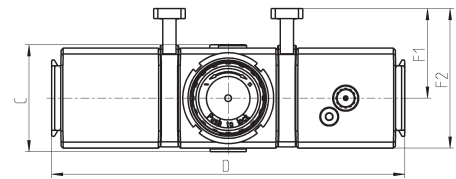
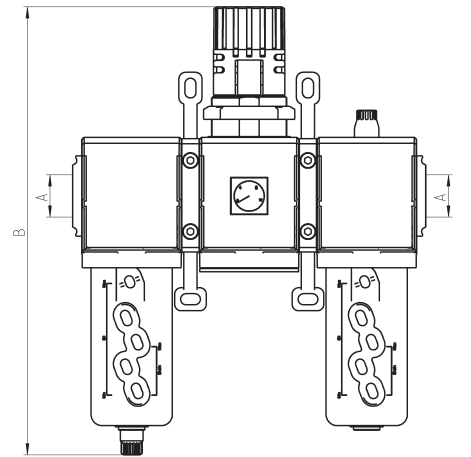

Mod.	A	B	C	D	F1	F2
MX2-3/8-000001	G3/8	289	74,5	210	70	104,5
MX2-1/2-000001	G1/2	289	74,5	210	70	104,5
MX2-3/4-000001	G3/4	289	74,5	210	70	104,5
MX3-3/4-000001	G3/4	345	81	268,5	68	106
MX3-1-000001	G1	345	81	268,5	68	106

Composition of the assembled group 000002



Components:
Filter-regulator
Lubricator

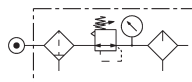
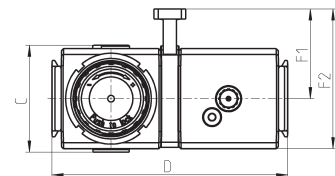
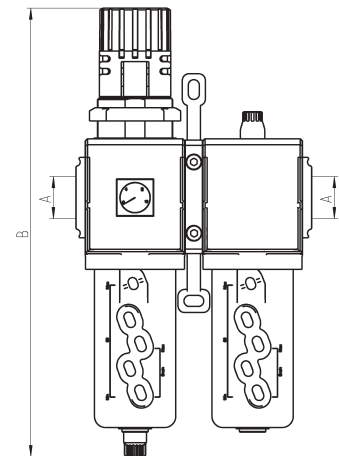

Mod.	A	B	C	D	F1	F2
MX2-3/8-000002	G3/8	289	74,5	140	70	104,5
MX2-1/2-000002	G1/2	289	74,5	140	70	104,5
MX2-3/4-000002	G3/4	289	74,5	140	70	104,5
MX3-3/4-000002	G3/4	345	81	179	68	106
MX3-1-000002	G1	345	81	179	68	106

Composition of the assembled group 000003



Components:
Lockable isolation 3/2-way valve
Filter-regulator
Lubricator

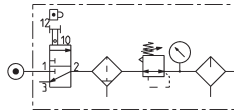
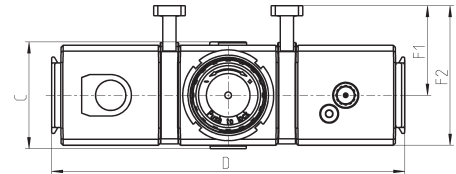
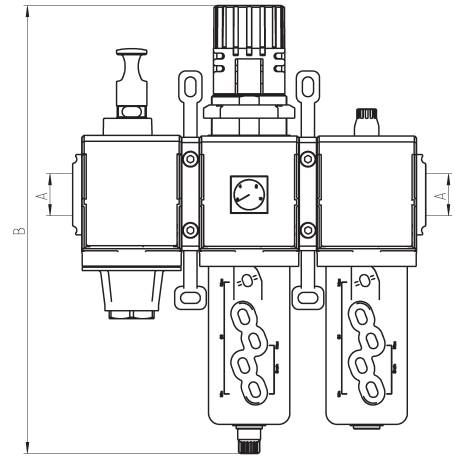

Mod.	A	B	C	D	F1	F2
MX2-3/8-000003	G3/8	289	74,5	210	70	104,5
MX2-1/2-000003	G1/2	289	74,5	210	70	104,5
MX2-3/4-000003	G3/4	289	74,5	210	70	104,5
MX3-3/4-000003	G3/4	345	81	268,5	68	106
MX3-1-000003	G1	345	81	268,5	68	106

Composition of the assembled group 000004



Components:
Lockable isolation 3/2-way valve
Filter-regulator

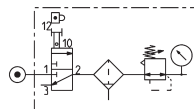
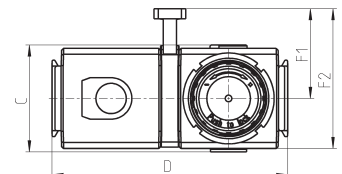
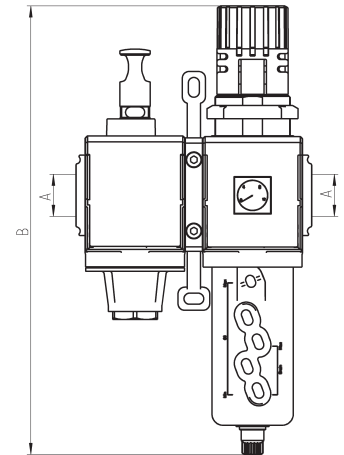

Mod.	A	B	C	D	F1	F2
MX2-3/8-000004	G3/8	289	74,5	140	70	104,5
MX2-1/2-000004	G1/2	289	74,5	140	70	104,5
MX2-3/4-000004	G3/4	289	74,5	140	70	104,5
MX3-3/4-000004	G3/4	345	81	179	68	106
MX3-1-000004	G1	345	81	179	68	106

Composition of the assembled group 000005



Components:
 Filter-regulator
 Lockable isolation 3/2-way valve
 Soft start valve

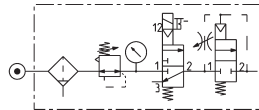
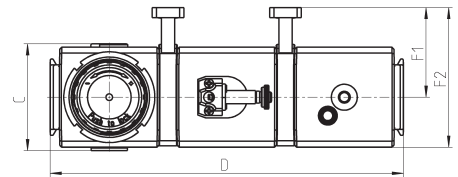
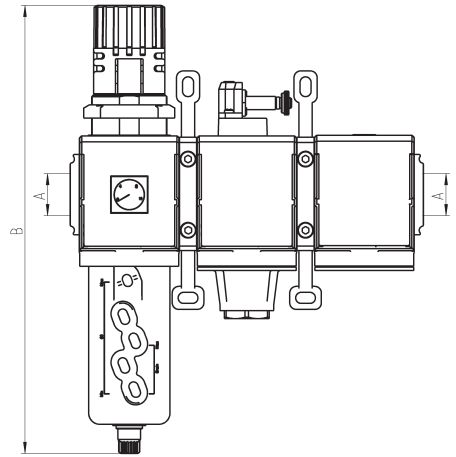

Mod.	A	B	C	D	F1	F2
MX2-3/8-000005	G3/8	289	74,5	210	70	104,5
MX2-1/2-000005	G1/2	289	74,5	210	70	104,5
MX2-3/4-000005	G3/4	289	74,5	210	70	104,5
MX3-3/4-000005	G3/4	345	81	268,5	68	106
MX3-1-000005	G1	345	81	268,5	68	106

Composition of the assembled group 000006



Components:
 Filter-regulator
 Lubricator
 Lockable isolation 3/2-way valve
 Soft start valve

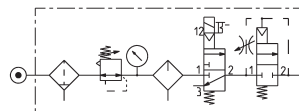
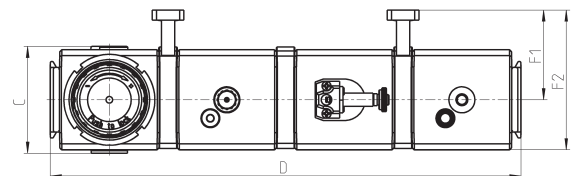
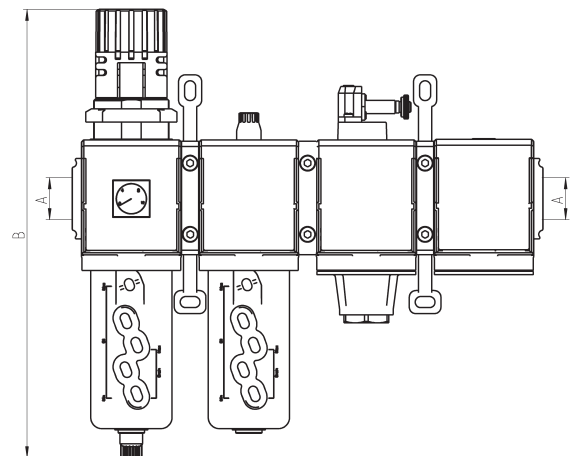

Mod.	A	B	C	D	F1	F2
MX2-3/8-000006	G3/8	289	74,5	280	70	104,5
MX2-1/2-000006	G1/2	289	74,5	280	70	104,5
MX2-3/4-000006	G3/4	289	74,5	280	70	104,5
MX3-3/4-000006	G3/4	345	81	358	68	106
MX3-1-000006	G1	345	81	358	68	106

Composition of the assembled group 000007



- Components:
 Lockable isolation 3/2-way valve
 Filter-regulator
 Lockable isolation 3/2-way valve
 Soft start valve

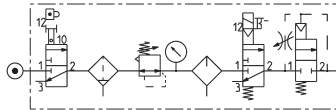
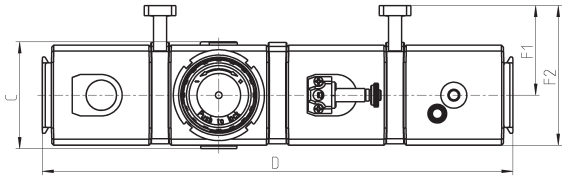
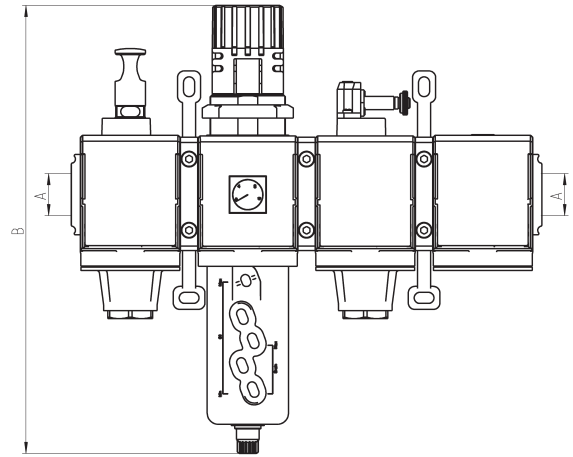

Mod.	A	B	C	D	F1	F2
MX2-3/8-000007	G3/8	289	74,5	280	70	104,5
MX2-1/2-000007	G1/2	289	74,5	280	70	104,5
MX2-3/4-000007	G3/4	289	74,5	280	70	104,5
MX3-3/4-000007	G3/4	345	81	358	68	106
MX3-1-000007	G1	345	81	358	68	106

Composition of the assembled group 000008



- Components:
 Lockable isolation 3/2-way valve
 Filter-regulator
 Lubricator
 Lockable isolation 3/2-way valve
 Soft start valve + pressure switch (NO)

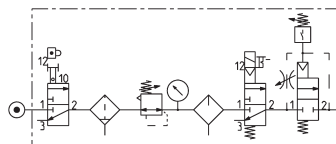
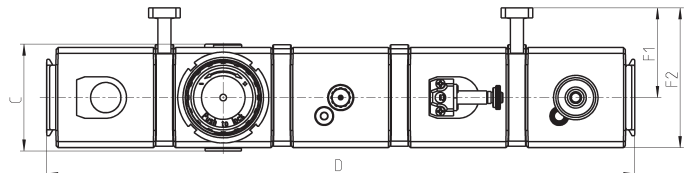
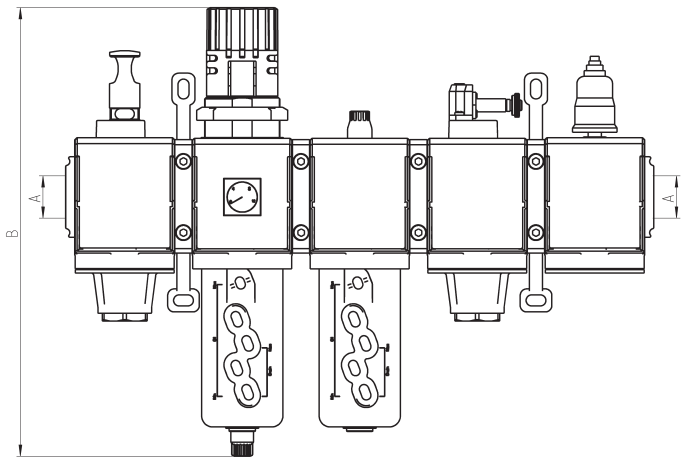

Mod.	A	B	C	D	F1	F2
MX2-3/8-000008	G3/8	289	74,5	350	70	104,5
MX2-1/2-000008	G1/2	289	74,5	350	70	104,5
MX2-3/4-000008	G3/4	289	74,5	350	70	104,5
MX3-3/4-000008	G3/4	345	81	447,5	68	106
MX3-1-000008	G1	345	81	447,5	68	106

Composition of the assembled group 000009



- Components:
 Lockable isolation 3/2-way valve
 Filter-regulator
 Lubricator
 Lockable isolation 3/2-way valve
 Soft start valve + pressure switch (NC)

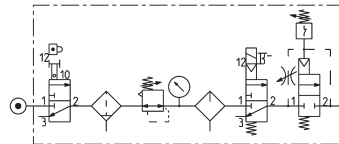
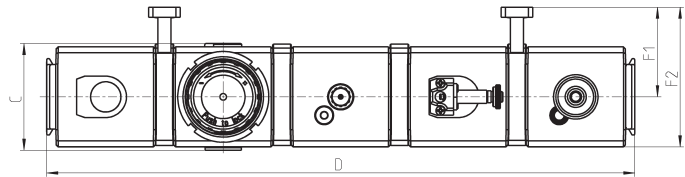
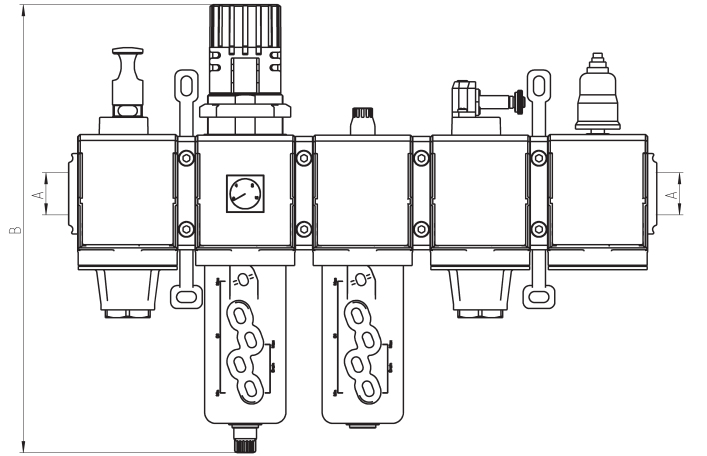

Mod.	A	B	C	D	F1	F2
MX2-3/8-000009	G3/8	289	74,5	350	70	104,5
MX2-1/2-000009	G1/2	289	74,5	350	70	104,5
MX2-3/4-000009	G3/4	289	74,5	350	70	104,5
MX3-3/4-000009	G3/4	345	81	447,5	68	106
MX3-1-000009	G1	345	81	447,5	68	106

Composition of the assembled group 000010



- Components:
 Lockable isolation 3/2-way valve
 Filter-regulator
 Lockable isolation 3/2-way valve
 Soft start valve + pressure switch (NO)

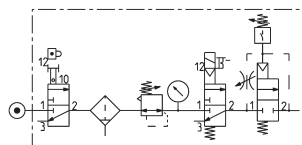
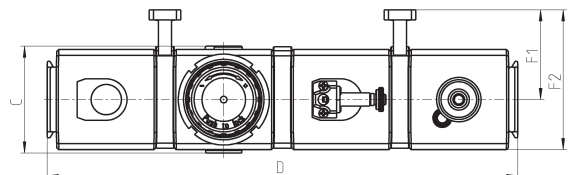
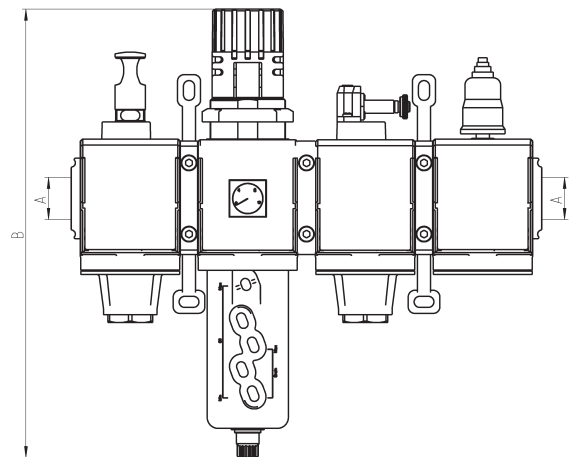

Mod.	A	B	C	D	F1	F2
MX2-3/8-000010	G3/8	289	74,5	280	70	104,5
MX2-1/2-000010	G1/2	289	74,5	280	70	104,5
MX2-3/4-000010	G3/4	289	74,5	280	70	104,5
MX3-3/4-000010	G3/4	345	81	358	68	106
MX3-1-000010	G1	345	81	358	68	106

Composition of the assembled group 000011



- Components:
- Lockable isolation 3/2-way valve
- Filter-regulator
- Lockable isolation 3/2-way valve
- Soft start valve + pressure switch (NC)

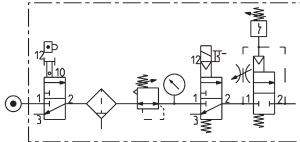
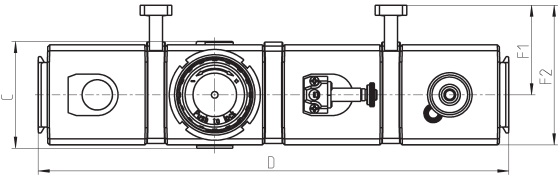
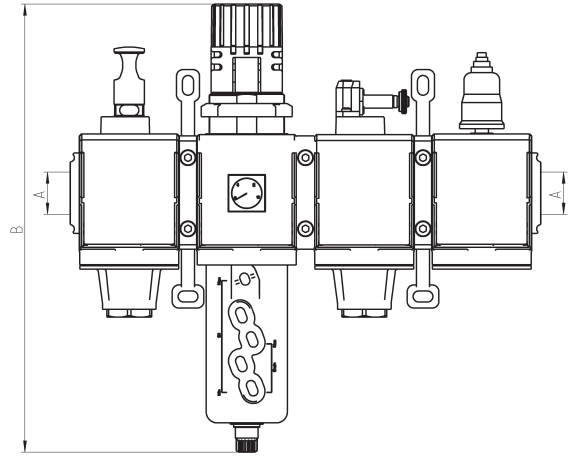

Mod.	A	B	C	D	F1	F2
MX2-3/8-000011	G3/8	289	74,5	280	70	104,5
MX2-1/2-000011	G1/2	289	74,5	280	70	104,5
MX2-3/4-000011	G3/4	289	74,5	280	70	104,5
MX3-3/4-000011	G3/4	345	81	358	68	106
MX3-1-000011	G1	345	81	358	68	106

Composition of the assembled group 000012



- Components:
- Filter
- Coalescing filter

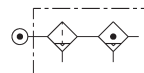
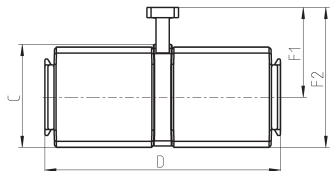
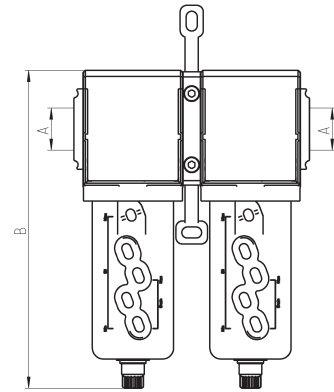

Mod.	A	B	C	D	F1	F2
MX2-3/8-000012	G3/8	210	72	140	70	104,5
MX2-1/2-000012	G1/2	210	72	140	70	104,5
MX2-3/4-000012	G3/4	210	72	140	70	104,5
MX3-3/4-000012	G3/4	231	78	179	68	106
MX3-1-000012	G1	231	78	179	68	106

Series MC filters

Ports G1/4, G3/8 and G1/2
Modular
Metal bowl and bayonet-type mounting



- » Removal of impurities and condensate
- » Quality of delivered air according to ISO 8573-1:2010, Classes 7.8.4 and 6.8.4
- » Manual, automatic or depressuring drain

Series MC filters are available with ports G1/4, G3/8 and G1/2. Bowls are made of metal with a transparent sight glass and have a condensate drain valve which can provide either a manual or semi-automatic function.

GENERAL DATA

Construction	compact modular with filtering element in HDPE
Materials	zama, NBR, tecnopolymer
Ports	G1/4 G3/8 G1/2
Max condensate capacity	cm ³ 28 cm ³ 72 cm ³ 72
Weight	kg 0,339 kg 0,718 kg 0,688
Mounting	vertical in-line or wall-mounting
Operating temperature	-5°C ÷ 50°C at 10 bar (with the dew point of the fluid lower than 2°C at the min. working temperature)
Quality of delivered air according to ISO 8573-1:2010	Class 6.8.4 with 5µm filtering element Class 7.8.4 with 25µm filtering element
Draining of condensate	semi-automatic manual, automatic protected depressurisation, direct G1/8 exhaust
Finishing	enamelled
Operating pressure	with standard drain and protected depressurisation 0.3 ÷ 16 bar with depressurisation 0.3 ÷ 10 bar with automatic drain 1.5 ÷ 12 bar for G3/8 and G1/2
Nominal flow	see FLOW DIAGRAMS on the following pages
Fluid	compressed air

CODING EXAMPLE

MC	2	02	-	F	0	0
-----------	----------	-----------	----------	----------	----------	----------

MC	SERIES
2	SIZE: 1 = G1/4 2 = G3/8 - G1/2
02	PORTS: 04 = G1/4 38 = G3/8 02 = G1/2
F	F = FILTER
0	FILTERING ELEMENT: 0 = 25µm (standard) 1 = 5µm
0	DRAINING OF CONDENSATE (further details in the dedicated section): 0 = normal - semiautomatic (standard) 3 = automatic drain (only for G3/8 and G1/2) 4 = depressurisation (only G1/4) 5 = depressurisation, protected 8 = no drain, port 1/8

SERIES MC FILTERS

Filters Series MC



FT01 = filter without drain with threaded port
FT02 = filter with semiautomatic manual drain
FT03 = filter with automatic drain

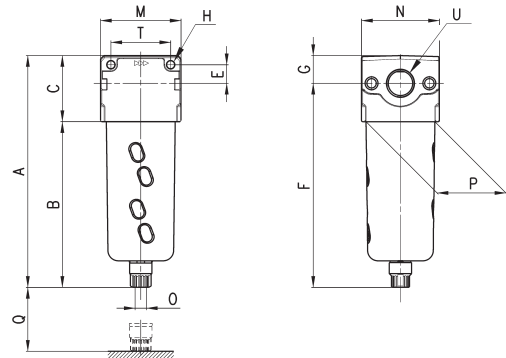
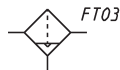
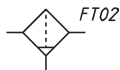
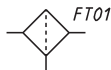

DIMENSIONS														
Mod.	A	B	C	E	F	G	H	M	N	O	P	Q	T	U
MC104-F00	143	102	41	11	126,5	16,5	4,5	45	45	G1/8	37	58	35	G1/4
MC238-F00	184	133	51	14	163	21	5,5	62	60	G1/8	53	72	46	G3/8
MC202-F00	184	133	51	14	163	21	5,5	62	60	G1/8	53	72	46	G1/2

FLOW DIAGRAMS FOR FILTERS SERIES MC, G1/4 - G3/8 PORTS

SERIES MC FILTERS

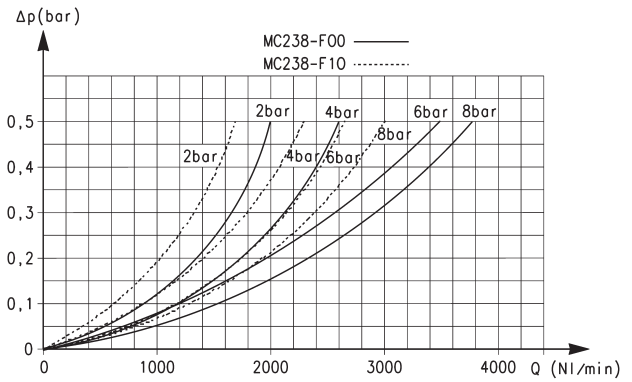
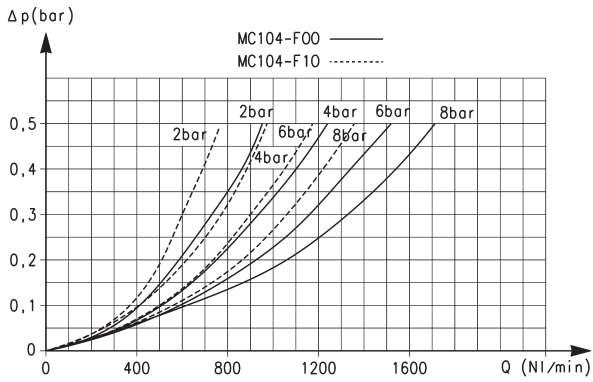

Flow diagram for models: MC238-F00 and MC238-F10

ΔP = Pressure drop (bar)
Q = Flow (NI/min)

Flow diagram for models: MC104-F00 and MC104-F10

ΔP = Pressure drop (bar)
Q = Flow (NI/min)

FLOW DIAGRAM FOR FILTERS SERIES MC, G1/2 PORTS

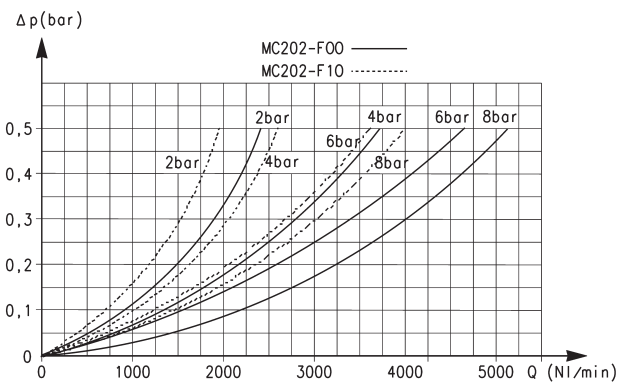

Flow diagram for models: MC202-F00 and MC202-F10

ΔP = Pressure drop (bar)
Q = Flow (NI/min)

Series MC coalescing filters

Ports G1/4, G3/8 and G1/2
Modular
Metal bowl and bayonet-type mounting



- » Quality of delivered air according to ISO 8573-1:2010, Class 1.8.1
- » Manual, automatic or depressuring drain

Series MC coalescing filters are available with G1/4, G3/8 and G1/2 ports. The bowls of these filters are made of metal with a transparent sight glass and may have a condensate drain valve which can provide either a manual or semi-automatic function.

GENERAL DATA

Construction	modular, coalescing elements
Materials	zama, NBR, technopolymer
Ports	G1/4 G3/8 G1/2
Weight	kg 0.342 0.718 0.688
Mounting	vertical in line or wall-mounting
Operating temperature	-5°C ÷ 50°C at 10 bar (with the dew point of the fluid lower than 2°C at the min. working temperature)
Quality of delivered air according to ISO 8573-1:2010	Class 1.8.1 with 0.01 µm filtering element
Draining of condensate	manual - semi-automatic (standard), automatic, with depressurisation, protected depressurisation, without drain with port G1/8
Finish	enamelled
Operating pressure	with standard drain and protected depressurisation 0.3 ÷ 16 bar with depressurisation 0.3 ÷ 10 bar with automatic drain 1.5 ÷ 12 bar for G3/8 and G1/2
Residual oil content with inlet at 3 mg/m³	< 0.01mg/m ³
Oil retain efficiency	99.80%
Particles retain efficiency	99.99999%
Nominal flow	see FLOW DIAGRAMS on the following pages
Fluid	compressed air

CODING EXAMPLE

MC	2	02	-	F	B	0
MC	SERIES					
2	SIZE: 1 = G1/4 2 = G3/8 - G1/2					
02	PORTS: 04 = G1/4 38 = G3/8 02 = G1/2					
F	F = FILTER					
B	FILTERING ELEMENT: B = 0,01µm					
0	DRAINING OF CONDENSATE (further details in the dedicated section): 0 = manual - semi-automatic 3 = automatic (only for G3/8 and G1/2) 4 = depressurisation (only G1/4) 5 = depressurisation, protected 8 = no drain, port 1/8					

SERIES MC COALESCING FILTERS

Coalescing filters Series MC



FA01 = coalescing filter without drain with threaded port
 FA02 = coalescing filter with semi-automatic manual drain
 FA03 = coalescing filter with automatic drain

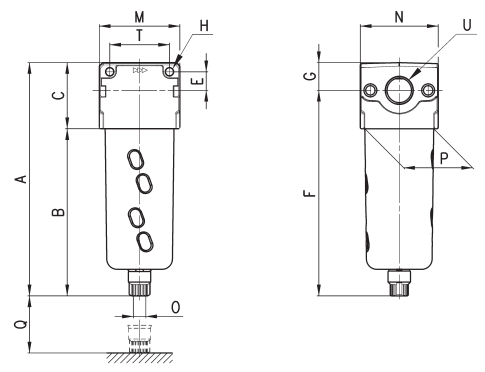
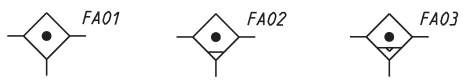

DIMENSIONS															
Mod.	A	B	C	E	F	G	H	M	N	O	P	Q	T	U	
MC104-FB0	143	102	41	11	126,5	16,5	4,5	45	45	G1/8	37	54	35	G1/4	
MC238-FB0	184	133	51	14	163	21	5,5	62	60	G1/8	53	73	46	G3/8	
MC202-FB0	184	133	51	14	163	21	5,5	62	60	G1/8	53	73	46	G1/2	

Products designed for industrial applications.
 General terms and conditions for sale are available on www.camozzi.com.

FLOW DIAGRAMS

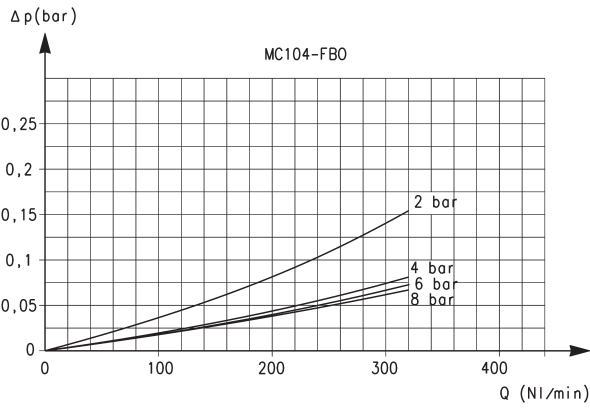

Flow diagram for model: MC104-FB0

ΔP = Pressure drop (bar)
Q = Flow (NL/min)

In order to guarantee the indicated performances, the maximum flow of the filter must be the one indicated in the graph. A higher flow rate is possible but the same performances are not guaranteed.

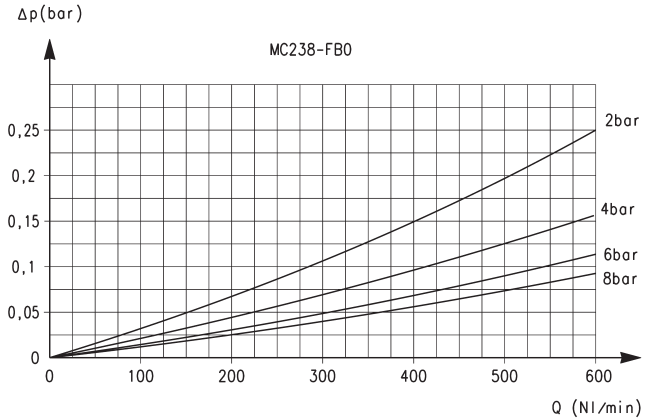

Flow diagram for model: MC238-FB0

ΔP = Pressure drop (bar)
Q = Flow (NL/min)

In order to guarantee the indicated performances, the maximum flow of the filter must be the one indicated in the graph. A higher flow rate is possible but the same performances are not guaranteed.

FLOW DIAGRAM

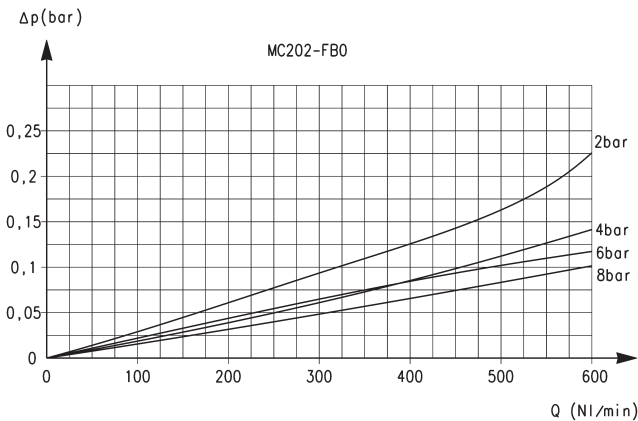

Flow diagram for model: MC202-FB0

ΔP = Pressure drop (bar)
Q = Flow (NL/min)

In order to guarantee the indicated performances, the maximum flow of the filter must be the one indicated in the graph. A higher flow rate is possible but the same performances are not guaranteed.

Series MC activated carbon filters



Ports: G1/4, G3/8 e G1/2

Modular

Metal bowl and bayonet-type mounting



- » Removal of oil, liquid and gaseous components from compressed air through the activated carbon
- » Quality of delivered air according to ISO 8573-1:2010, Class 1.7.1

The activated carbon filters Serie MC are available with port G1/4, G3/8 and G1/2. The bowls of these filters are made of metal with a transparent sight glass

GENERAL DATA

Construction	modular, compact with activated carbon filtering element			
Materials	zama, NBR, tecnopolymer, activated carbon			
Ports	G1/4	G3/8	G1/2	
Weight	Kg	0,342	0,718	0,688
Mounting	vertical in line or wall-mounting			
Operating temperature	10°C ÷ 40°C (t max = 60°C)			
Quality of delivered air according to ISO 8573-1:2010	Class 1.7.1			
Condensate drain	not present			
Mounting	vertical in-line; wall-mounting by means of through holes in the body or with a support bracket			
Operating pressure	0.3 ÷ 16 bar			
Nominal flow	see FLOW DIAGRAMS on the following pages			
Filtering element	active carbon			
Residual oil content	< 0.003 mg/m ³			
Fluid	compressed air			
Pre-filtering	it is recommended to use a filter with residual oil of 0,01mg/m ³			

CODING EXAMPLE

MC	2	02	-	F	CA
-----------	----------	-----------	----------	----------	-----------

MC	SERIES
2	SIZE: 1 = G1/4 2 = G3/8 - G1/2
02	PORTS: 04 = G1/4 38 = G3/8 02 = G1/2
F	FILTER
CA	CA = Activated carbon

SERIES MC ACTIVATED CARBON FILTERS

Series MC activated carbon filters



FC01 = Absorption function without bowl hole

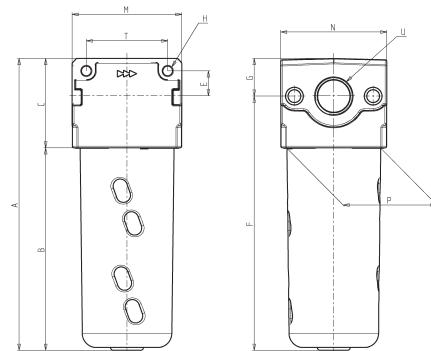

Mod.	A	B	C	E	F	G	H	M	N	P	T	U
MC104-FCA	124	83	41	11	107,5	16,5	4,5	45	45	37	35	G1/4
MC238-FCA	166	115	51	14	145	21	5,5	62	60	53	46	G3/8
MC202-FCA	166	115	51	14	145	21	5,5	62	60	53	46	G1/2

FLOW DIAGRAMS

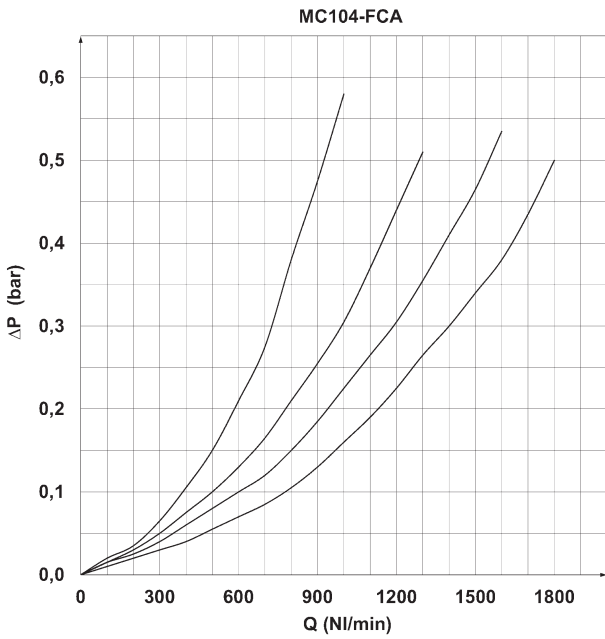

Flow diagram for model: MC104-FCA
 ΔP = Pressure drop (bar)
 Q = Flow (NL/min)

In order to guarantee the indicated performances, the maximum flow of the filter must be the one indicated in the graph. A higher flow rate is possible but the same performances are not guaranteed.

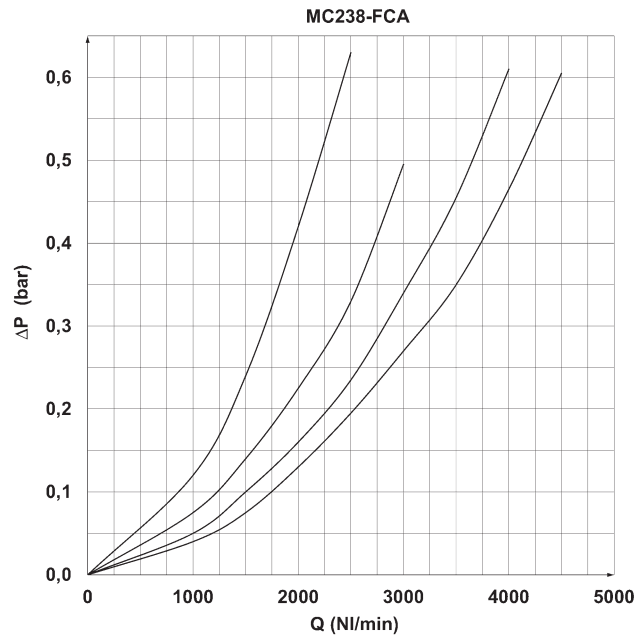

Flow diagram for model: MC238-FCA
 ΔP = Pressure drop (bar)
 Q = Flow (NL/min)

In order to guarantee the indicated performances, the maximum flow of the filter must be the one indicated in the graph. A higher flow rate is possible but the same performances are not guaranteed.

FLOW DIAGRAM

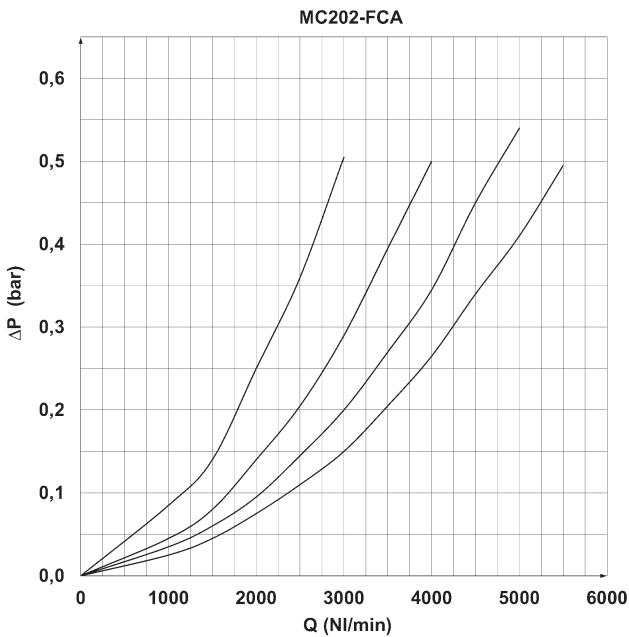

Flow diagram for model: MC202-FCA
 ΔP = Pressure drop (bar)
 Q = Flow (NL/min)

In order to guarantee the indicated performances, the maximum flow of the filter must be the one indicated in the graph. A higher flow rate is possible but the same performances are not guaranteed.

Series MC pressure regulators

Ports G1/4, G3/8 and G1/2
Modular



- » Minimal pressure decreases
- » Lockable knob with closure
- » Integral return exhaust (relieving)
- » Versions available: with by-pass valve or Manifold

Series MC pressure regulators are available with ports G1/4, G3/8 and G1/2. Versions with secondary pressure relieving are usually available and all regulators can be panel mounted.

GENERAL DATA

Construction	modular, compact, diaphragm type		
Materials	zama, brass, NBR, technopolymer		
Ports	G1/4	G3/8	G1/2
Weight	kg	0,323	0,644 0,624
Mounting	in-line, wall or panel mounting (in any position)		
Operating temperature	-5°C ÷ 50°C (with the dew point of the fluid lower than 2°C at the min. working temperature)		
Finishing	enamelled		
Inlet pressure	0 ÷ 16 bar		
Outlet pressure	0.5 ÷ 10 bar (standard) or 0.5 ÷ 2 bar; 0.5 ÷ 4 bar and 0.5 ÷ 7 bar		
Nominal flow	see FLOW DIAGRAMS on the following pages		
Secondary pressure (relieving)	with relieving (standard) without relieving		
Fluid	compressed air		

CODING EXAMPLE

MC	2	02	-	R	T	0	2	-	VS	-	■	-	●
----	---	----	---	---	---	---	---	---	----	---	---	---	---

MC	SERIES
2	SIZE: 1 = G1/4 2 = G3/8 - G1/2
02	PORTS: 04 = G1/4 38 = G3/8 02 = G1/2
R	REGULATOR
T	WORKING PRESSURE 0 = 0.5 ÷ 10 bar (standard) 1 = 0.5 ÷ 4 bar 2 = 0.5 ÷ 2 bar (only G1/4) 7 = 0.5 ÷ 7 bar (only G1/4) T = calibrated* B = locked*
0	CONSTRUCTION: 0 = self-relieving (standard) 1 = non-relieving 5 = precise relieving
2	PRESSURE GAUGE: ** = without pressure gauge (standard) 1 = with pressure gauge 0-2.5, with working pressure 0.5 ÷ 2 bar 2 = with pressure gauge 0-6, with working pressure 0.5 ÷ 4 bar 3 = with pressure gauge 0-10, with working pressure 0.5 ÷ 7 bar 4 = with pressure gauge 0-12, with working pressure 0.5 ÷ 10 bar
VS	TIPO DI REGOLAZIONE: = without by-pass valve (standard) VS = with by-pass valve (solo G1/4)
<p>** NOTE: IF THE REGULATOR IS CALIBRATED OR LOCKED, AFTER THE PORTS ADD THE INLET PRESSURE "■" AND THE OUTLET PRESSURE "●"</p> <p>INLET PRESSURE: ■ = enter the SUPPLY pressure value</p> <p>OUTLET PRESSURE: ● = enter the OUTLET pressure value for the LOCKED regulator or the maximum value of the ADJUSTABLE pressure for the CALIBRATED regulator</p> <p>Example of a calibrated regulator with Inlet Pressure = 6.3 bar and Outlet Pressure = 4.5 bar Complete part number: MC104-MT03-6.3-4.5</p> <p>** the pressure gauges are supplied disassembly for size 1 pressure gauge mod. M043-P. for size 2 pressure gauge mod. M053-P..</p>	

Pressure regulators Series MC

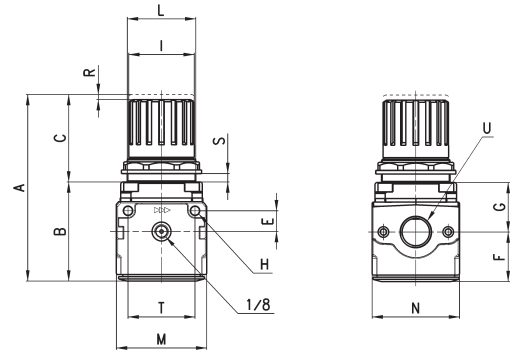

DIMENSIONS																
Mod.	A	B	C	E	F	G	H	I	L	M	N	R	S	T	U	
MC104-R00	94	56	38	11	28,5	27,5	4,5	28	30X1,5	45	45	3	0÷6	35	G1/4	
MC238-R00	127	67	60	14	34	35	5,5	45	47X1,5	62	60	3,5	0÷9	46	G3/8	
MC202-R00	127	67	60	14	34	35	5,5	45	47X1,5	62	60	3,5	0÷9	46	G1/2	

Pneumatic symbols

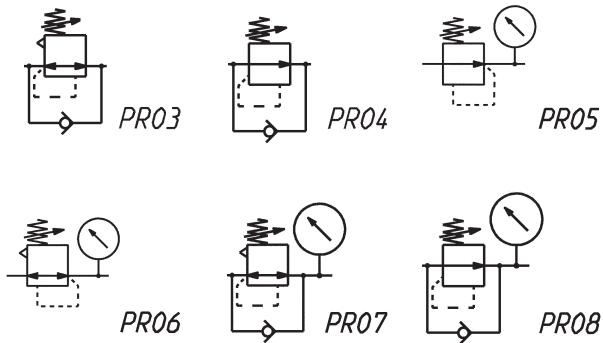

- PR03 = Regulator with relieving and by-pass valve
- PR04 = Regulator without relieving and with by-pass valve
- PR05 = Regulator without relieving and with pressure gauge
- PR06 = Regulator with relieving and pressure gauge
- PR07 = Regulator with relieving, by-pass valve and pressure gauge
- PR08 = Regulator without relieving with by-pass valve and pressure gauge

FLOW DIAGRAMS

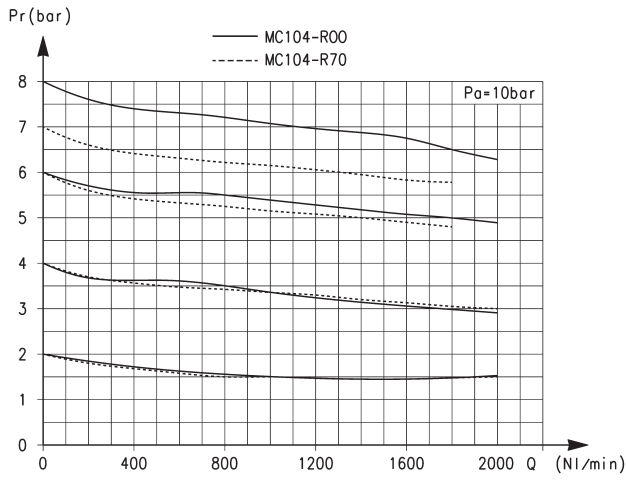

Flow diagrams for models: MC104-R00 and MC104-R70

Pa = Inlet pressure (bar)
Pr = Regulated pressure (bar)
Q = Flow (NI/min)

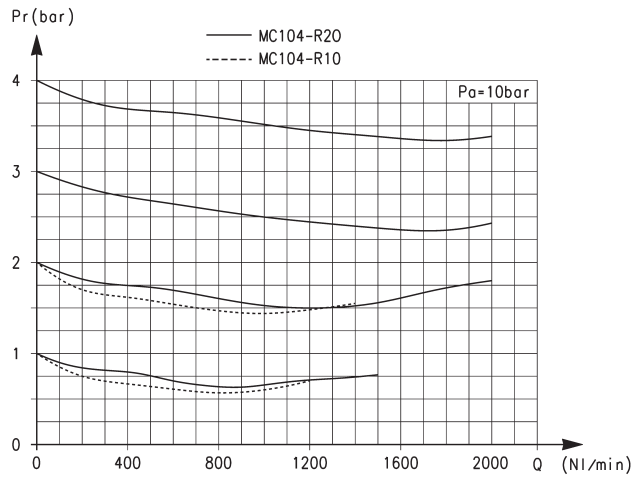

Flow diagrams for models: MC104-R10 and MC104-R20

Pa = Inlet pressure (bar)
Pr = Regulated pressure (bar)
Q = Flow (NI/min)

FLOW DIAGRAMS

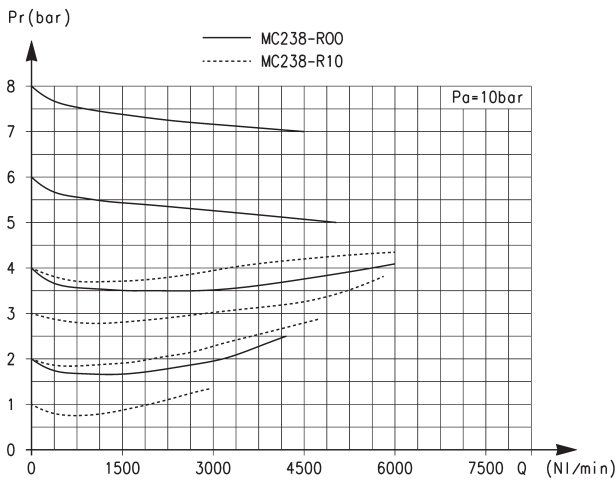

Flow diagrams for models: MC238-R00 and MC238-R10

Pa = Inlet pressure (bar)
Pr = Regulated pressure (bar)
Q = Flow (NI/min)

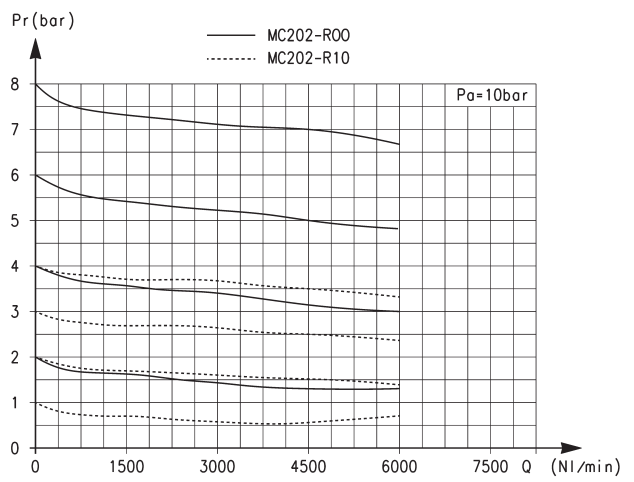

Flow diagrams for models: MC202-R00 and MC202-R10

Pa = Inlet pressure (bar)
Pr = Regulated pressure (bar)
Q = Flow (NI/min)

Series MC lubricators

Ports G1/4, G3/8 and G1/2
Modular
with metal bowl and bayonet-type mounting



- » Adjustment screw
- » Check of the oil level through plastic cover openings

Series MC lubricators are available with ports G1/4, G3/8 and G1/2. The bowls of these lubricators are made of metal and are equipped with a transparent viewer. The oil flow can be monitored through the small transparent cap and regulated by means of the proper adjusting screw.

GENERAL DATA

Construction	modular compact
Materials	zama, NBR, technopolymer
Ports	G1/4 G3/8 G1/2
Oil capacity	cm ³ 37 170 170
Weight	kg 0,338 0,712 0,674
Mounting	vertical in-line or wall-mounting
Operating temperature	-5°C ÷ 50°C at 10 bar (with the dew point of the fluid lower than 2°C at the min. working temperature)
Oil refilling	without pressure (G1/4) also during use (G3/8 - G1/2)
Oil for lubrication	use ISO VG32 oils. Once applied, the lubrication should never be interrupted.
Finishing	enamelled
Operating pressure	0 ÷ 16 bar
Min. air consumption for lubr (NL/min)	G1/4 - G3/8 - G1/2
at 1 bar	8 - 8 - 8,5
at 6 bar	15 - 17,5 - 15,5
Nominal flow	see FLOW DIAGRAMS on the following pages
Fluid	compressed air

CODING EXAMPLE

MC	2	02	-	L	00
M	SERIES				
2	SIZE 1 = G1/4 2 = G3/8 - G1/2				
02	PORTS 04 = G1/4 38 = G3/8 02 = G1/2				
L	L = LUBRICATOR				
00	DESIGN TYPE 00 = atomized oil				

SERIES MC LUBRICATORS

Lubricators Series MC



LU0 = Lubricator

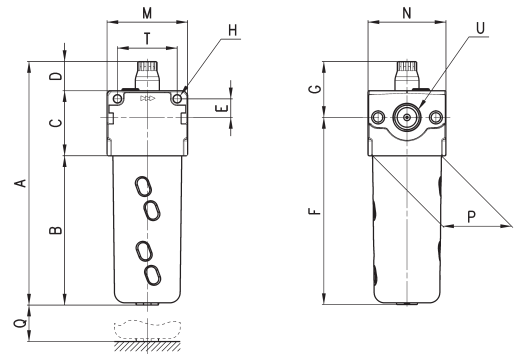
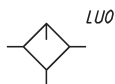

DIMENSIONS															
Mod.	A	B	C	D	E	F	G	H	M	N	P	Q	T	U	
MC104-L00	148	83	40	25	11	107	41	4,5	45	45	37	84	35	G1/4	
MC238-L00	187	115	50	22	14	144	43	5,5	62	60	53	117	46	G3/8	
MC202-L00	187	115	50	22	14	144	43	5,5	62	60	53	117	46	G1/2	

FLOW DIAGRAMS

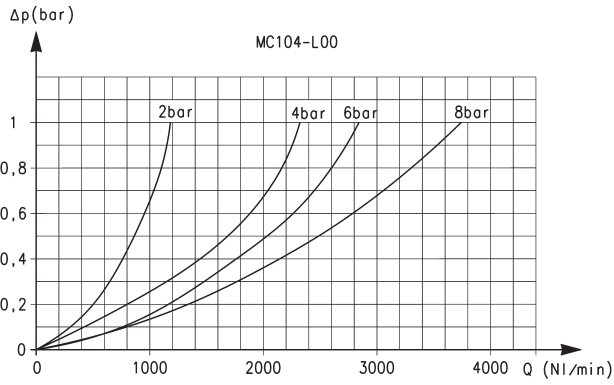

Flow diagram for model: MC104-L00

ΔP = Pressure drop (bar)
Q = Flow (NL/min)

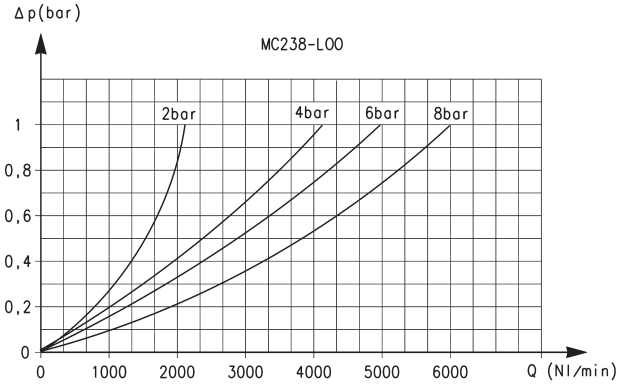

Flow diagram for model: MC238-L00

ΔP = Pressure drop (bar)
Q = Flow (NL/min)

FLOW DIAGRAM

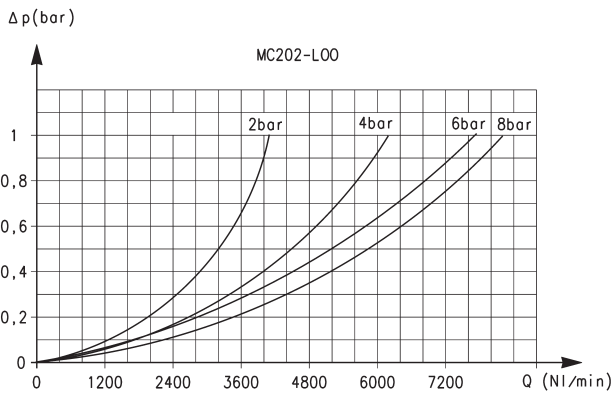

Flow diagram for model: MC202-L00

ΔP = Pressure drop (bar)
Q = Flow (NL/min)

Series MC filter-regulators

Ports G1/4, G3/8 and G1/2
Modular
Metal bowl and bayonet-type mounting



- » Quality of delivered air according to ISO 8573-1:2010, Classes 7.8.4 and 6.8.4
- » Minimal pressure decreases
- » Knob with closure
- » Integral return exhaust (relieving)
- » Available versions: with by-pass valve

Series MC filter regulators are available with ports G1/4, G3/8 and G1/2. They combine the features of the filters and regulators and have smaller overall dimensions than the two separate components.

GENERAL DATA

Construction	compact modular with filtering element in HDPE		
Materials	zama, NBR, technopolymer		
Ports	G1/4	G3/8	G1/2
Condensate capacity	cm ³	28	72
Weight	kg	0,443	0,948
Mounting	vertical in-line or wall-mounting		
Operating temperature	-5°C ÷ 50°C at 10 bar (with the dew point of the fluid lower than 2°C at the min. working temperature)		
Quality of delivered air according to ISO 8573-1:2010	Class 6.8.4 with 5µm filtering element Class 7.8.4 with 25µm filtering element		
Draining of condensate	semi-automatic manual (standard), automatic, with depressurisation, protected depressurisation, without drain with port G1/8		
Finishing	enamelled		
Inlet pressure	with standard drain and protected depressurisation 0.3 ÷ 16 bar with depressurisation 0.3 ÷ 10 bar with automatic drain 1.5 ÷ 12 bar for G3/8 and G1/2		
Outlet pressure	0.5 ÷ 10 bar(standard), 0.5 ÷ 2 bar; 0.5 ÷ 4 bar e 0.5 ÷ 7 bar		
Nominal flow	see FLOW DIAGRAMS on the following pages		
Fluid	compressed air		

CODING EXAMPLE

MC	2	02	-	D	0	0	2	-	4	-	VS
-----------	----------	-----------	----------	----------	----------	----------	----------	----------	----------	----------	-----------

MC	SERIES
2	SIZE: 1 = G1/4 2 = G3/8 - G1/2
02	PORTS: 04 = G1/4 38 = G3/8 02 = G1/2
D	D = FILTER-REGULATOR
0	FILTERING ELEMENT: 0 = 25µm (standard) 1 = 5µm
0	DRAINING OF CONDENSATE (further details in the dedicated section): 0 = manual semiautomatic, self-relieving 1 = manual semiautomatic, non relieving 3 = automatic, self-relieving (only for G3/8 and G1/2) 4 = depressurisation, self-relieving (only G1/4) 5 = depressurisation, protected, self-relieving 8 = no drain, port G1/8, self-relieving
2	PRESSURE GAUGE: ** = without pressure gauge (standard) 1 = with pressure gauge 0-2,5, with working pressure 0.5 ÷ 2 bar 2 = with pressure gauge 0-6, with working pressure 0.5 ÷ 4 bar 3 = with pressure gauge 0-10, with working pressure 0.5 ÷ 7 bar 4 = with pressure gauge 0-12, with working pressure 0.5 ÷ 10 bar
4	WORKING PRESSURE = 0.5 ÷ 10 2 = 0.5 ÷ 2 (only G1/4) 4 = 0.5 ÷ 4 7 = 0.5 ÷ 7 (only G1/4)
VS	REGULATION TYPE: = without by-pass valve (standard) VS = with by-pass valve (only G1/4)
** the pressure gauges are supplied disassembly for size 1 pressure gauge mod. M043-P. for size 2 pressure gauge mod. M053-P.	

SERIES MC FILTER-REGULATORS

Filter-regulators Series MC

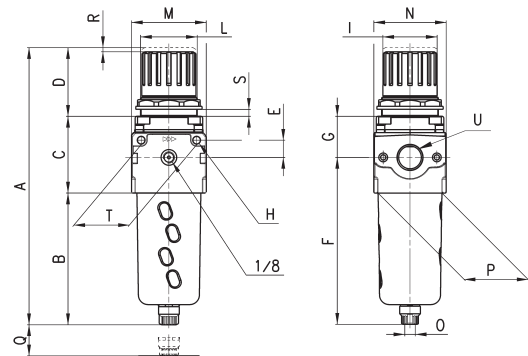

DIMENSIONS																			
Mod.	A	B	C	D	E	F	G	H	I	L	M	N	O	P	Q	R	S	T	U
MC104-D00	190,5	102	52	38	11	126,5	27,5	4,5	28	M30x1,5	45	45	G1/8	37	58	3	0 ÷ 6	35	G1/4
MC238-D00	256,5	133	64	59	14	162	35	5,5	45	M47x1,5	62	59	G1/8	53	72	3,5	0 ÷ 9	46	G3/8
MC202-D00	256,5	133	64	59	14	162	35	5,5	45	M47x1,5	62	59	G1/8	53	72	3,5	0 ÷ 9	46	G1/2

FLOW DIAGRAMS

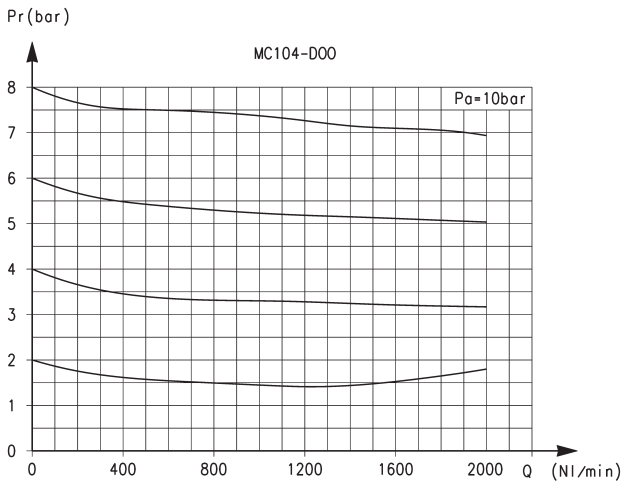

Pa = Inlet pressure (bar)
Pr = Regulated pressure (bar)
Q = Flow (NI/min)

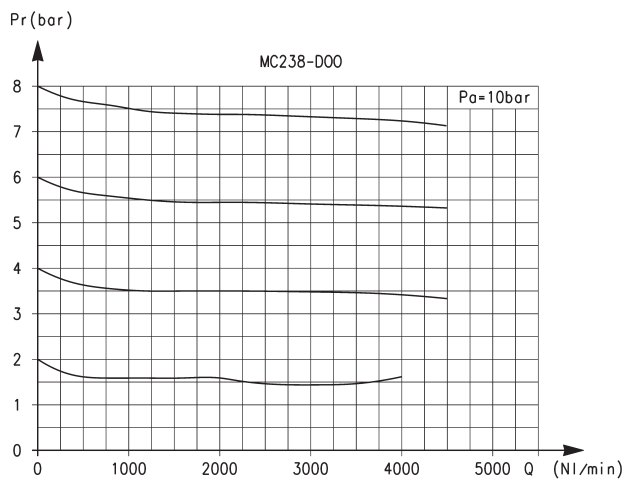

Pa = Inlet pressure (bar)
Pr = Regulated pressure (bar)
Q = Flow (NI/min)

SERIES MC FILTER-REGULATORS

FLOW DIAGRAM AND PNEUMATIC SYMBOLS

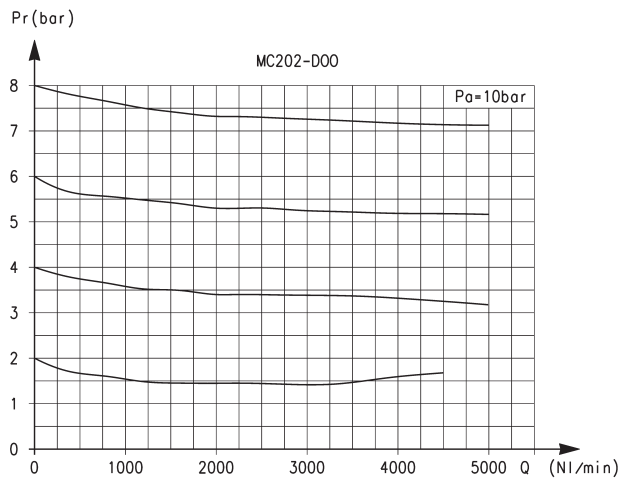

Pa = Inlet pressure (bar)
Pr = Regulated pressure (bar)
Q = Flow (bar)

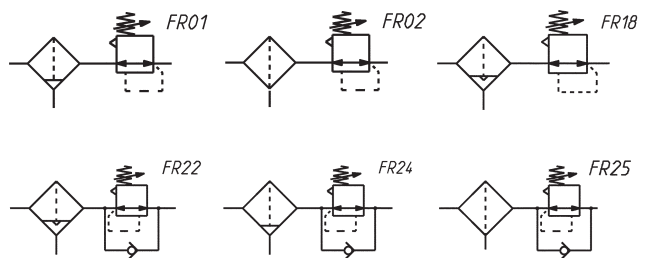

- FR01 = filter-reg. with relieving and manual/semiautomatic drain
- FR02 = filter-reg. with relieving and direct exhaust
- FR18 = filter-reg. with relieving and automatic drain
- FR22 = filter-reg. without relieving, with pressure gauge, automatic-depressurisation drain and by-pass valve
- FR24 = filter-reg. with relieving and manual/semiautomatic drain and by-pass valve
- FR25 = filter-reg. with relieving, direct exhaust and by-pass valve

Series MC lockable isolation 3/2-way valves

Electropneumatic, pneumatic and manual version
Ports G1/4, G3/8 and G1/2
Modular

SERIES MC LOCKABLE ISOLATION VALVES



- » Standard tamperproof lock-out (manual valve)
- » Actuation at 24 V, 110 V or 230 V
- » Exhaust in atmosphere

The 3-way lockable isolation valves are available in the electropneumatic, pneumatic and manual version and are designed to block the air inlet of the FRL group and so pressurise and depressurise the equipment.

Positioning of these valves is often before the FRL unit. The lockable isolation valves are available with ports G1/4, G3/8 and G1/2 and can be panel mounted.

GENERAL DATA

Construction	modular compact, poppet-type
Materials	zama, NBR, technopolymer
Ports	G1/4; G3/8; G1/2
Weight	kg 0.277 kg 0.536 kg 0.514
Mounting	in- line, wall or panel mounting (in any position)
Operating temperature	-5°C ÷ 50°C (with the dew point of the fluid lower than 2°C at the min. working temperature)
Finishing	enamelled
Operating pressure	Manual valve: -0.8 bar ÷ 10 bar Electro-pneumatic valve: 2 bar ÷ 10 bar Pneumatic valve: -0.8 bar ÷ 10 bar (with pilot 2 ÷ 10 bar)
Nominal exhaust flow at 6 bar with $\Delta p = 1$ bar	G1/4 = 1080 Nl/min G3/8 = 2380 Nl/min G1/2 = 2380 Nl/min
Nominal flow	see FLOW DIAGRAMS on the following pages
Fluid	compressed air

CODING EXAMPLE

MC	2	02	-	V	16
-----------	----------	-----------	----------	----------	-----------

MC	SERIES
2	SIZE: 1 = G1/4 2 = G3/8 - G1/2
02	PORTS: 04 = G1/4 38 = G3/8 02 = G1/2
V	V = 3/2-WAY VALVE
16	DESIGN TYPE: 16 = electropneumatic 36 = pneumatic 01 = padlock valve (manual command)

FLOW DIAGRAMS

SERIES MC LOCKABLE ISOLATION VALVES

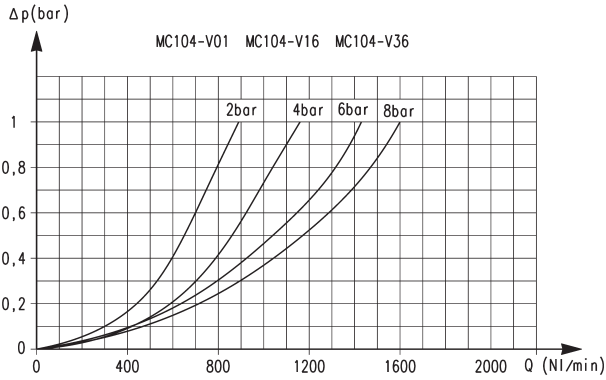

Flow diagram for models:
MC104-V01
MC104-V16
MC104-V36

Δp = Pressure drop (bar)
Q = Flow (NI/min)

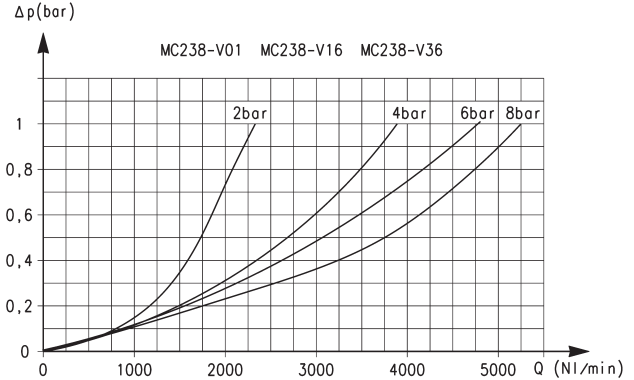

Flow diagram for models:
MC238-V01
MC238-V16
MC238-V36

Δp = Pressure drop (bar)
Q = Flow (NI/min)

FLOW DIAGRAM

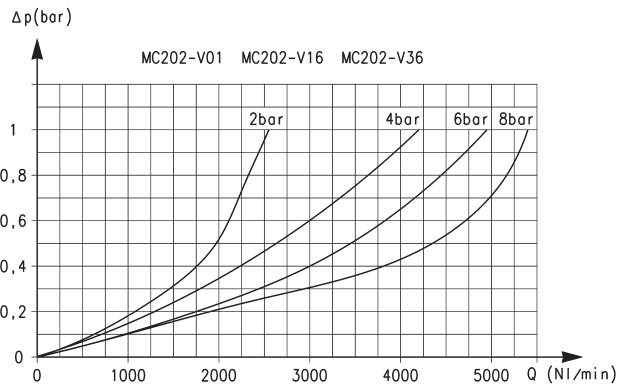

Flow diagram for models:
MC202-V01
MC202-V16
MC202-V36

Δp = Pressure drop (bar)
Q = Flow (NI/min)

Lockable isolation valves Series MC - manual version



VN27

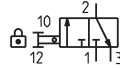

Actuating force at 6 bar :
 - MC104-V01 = 29N
 - MC238-V01 = 31N
 - MC202-V01 = 31N

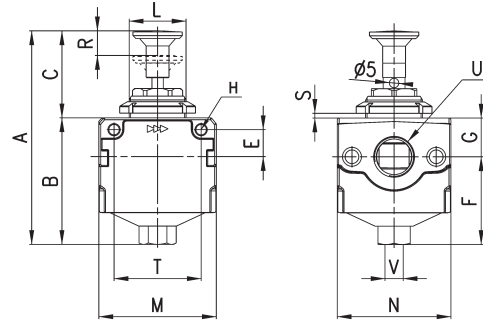

DIMENSIONS																	
Mod.	A	B	C	E	F	G	H	L	M	N	R	S	T	U	V		
MC104-V01	96,5	54,5	42	11	38,5	16	4,5	M30x1,5	45	45	9	0 ÷ 6	35	G1/4	G1/8		
MC238-V01	113	67	46	14	46,5	20,5	5,5	M30x1,5	62	60	13	0 ÷ 6	46	G3/8	G1/4		
MC202-V01	113	67	46	14	46,5	20,5	5,5	M30x1,5	62	60	13	0 ÷ 6	46	G1/2	G1/4		

Lockable isolation valves Series MC - electro-/pneumatic version



EV10 = solenoid valve, 3/2 NC, monostable, with bistable manual override
 YES1 = pneumatically operated valve, 3/2, monostable, mechanical spring

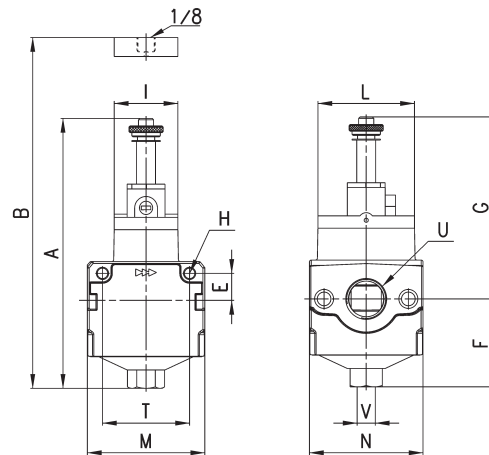
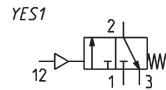
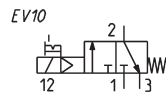

DIMENSIONS															
Mod.	A	B	E	F	G	H	I	L	M	N	T	U	V	Symbol	
MC104-V16	120	-	11	38,5	81,5	4,5	22	32	45	45	35	G1/4	G1/8	EV10	
MC238-V16	142,5	-	14	46,5	96	5,5	33,5	51	62	60	46	G3/8	G1/4	EV10	
MC202-V16	142,5	-	14	46,5	96	5,5	33,5	51	62	60	46	G1/2	G1/4	EV10	
MC104-V36	-	77,5	11	38,5	-	4,5	22	32	45	45	35	G1/4	G1/8	VP01	
MC238-V36	-	93,5	14	46,5	-	5,5	33,5	51	62	60	46	G3/8	G1/4	VP01	
MC202-V36	-	93,5	14	46,5	-	5,5	33,5	51	62	60	46	G1/2	G1/4	VP01	

Series MC soft start valves

Ports G1/4, G3/8 and G1/2
Modular



- » Safety function to maintain the command sequence
- » Opening of the main seat at about 50% of the inlet pressure

Series MC soft start valves are used to avoid damages to people or equipment when pressurising pneumatic systems containing cylinders.

The features of these components allow to pressurise an equipment up to 50% of the indicated pressure, after which 100% is reached rapidly.

The usual location of the soft start valve is after the FRL unit; in fact the modular design allows for perfect adaptability with all Series MC.

A pressure switch can be mounted into the upper part of the unit after removal of the S2610 G1/8 plug.

An electrical or pneumatic 3 way valve should be installed at the bottom of the unit to allow depressurisation.

GENERAL DATA

Construction	modular, compact, poppet type		
Materials	zama, NBR, technopolymer		
Ports	G1/4	G3/8	G1/2
Weight	Kg	0,275	0,566 0,544
Mounting	in-line wall or panel mounting (in any position)		
Operating temperature	-5°C ÷ 50°C (with the dew point of the fluid lower than 2°C at the min. working temperature)		
Finishing	enamelled		
Operating pressure	2 ÷ 10 bar		
Nominal flow (determined at 6 bar with ΔP1)	G1/4 = 1850 NI/min, G3/8 = 4000 NI/min, G1/2 = 4350 NI/min		
Fluid	compressed air		

CODING EXAMPLE

MC	2	02	-	AV
MC	SERIES			
2	SIZE: 1 = G1/4 2 = G3/8 - G1/2			
02	PORTS: 04 = G1/4 38 = G3/8 02 = G1/2			
AV	AV = SOFT START VALVE			

SERIES MC SOFT START VALVES

Soft start valve Series MC

X = adjustment screw

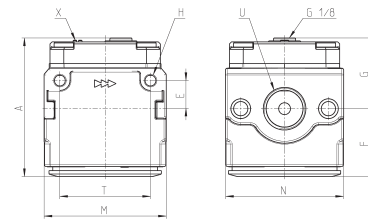

AVP1 = Soft start valve

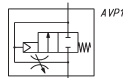

DIMENSIONS									
Mod.	A	E	F	G	H	M	N	T	U
MC104-AV	58,5	11	28,5	30	4,5	45	45	35	G1/4
MC238-AV	70	14	34	36	5,5	62	60	46	G3/8
MC202-AV	70	14	34	36	5,5	62	60	46	G1/2

DIAGRAMS FOR PRESSURISATION TIMES

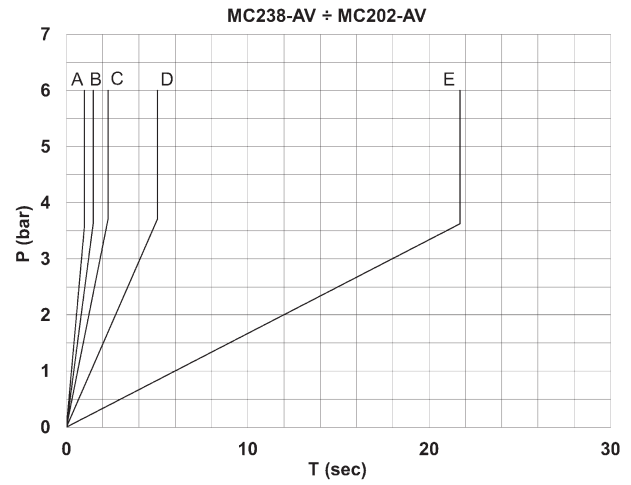
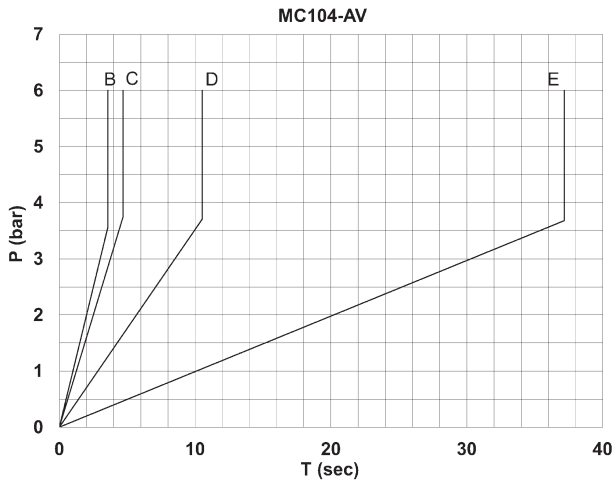

Pressurisation times as to the n° of turns of the regulation screw, with downstream volume of 5 litres. A = 5 turns - B = 4 turns - C = 3 turns - D = 2 turns - E = 1 turn. "K" = n° of turns of the regulation screw required to obtain the required pressurisation time with an inlet pressure of 6 bar. Variations of the inlet pressure can cause deviations of the pressure time by ± 20%. $K = t/V$ where: V = volume of the downstream system in litres; t = desired pressuring time in seconds.

Pressurisation times as to the n° of turns of the regulation screw, with downstream volume of 5 litres. A = 9 turns - B = 7 turns - C = 5 turns - D = 3 turns - E = 1 turn. "K" = n° of turns of the regulation screw required to obtain the required pressurisation time with an inlet pressure of 6 bar. Variations of the inlet pressure can cause deviations of the pressure time by ± 20%. $K = t/V$ where: V = volume of the downstream system in litres; t = desired pressuring time in seconds.

VARIATION IN PRESSURISATION - Example

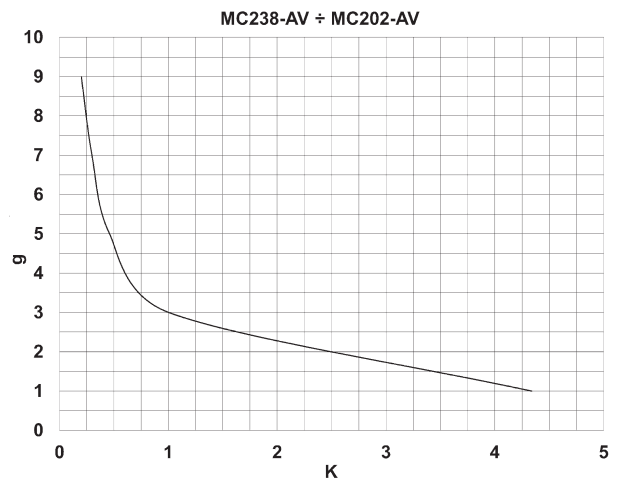
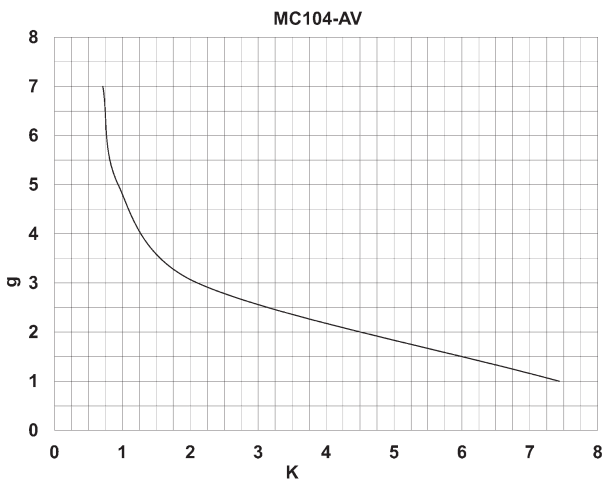

Example: MC104-AV
V = 5 litres
t = 16 seconds
 $K = 16/5 = 3,2$
g = number of turns
Using in the graph this value K, the number of turns of the regulation screw will be approx. 2,5.

Example: MC238-AV - MC202-AV
V = 5 litres
t = 16 seconds
 $K = 16/5 = 3,2$
g = number of turns
Using in the graph this value K, the number of turns of the regulation screw will be approx. 1,6.

Series MC take-off blocks

Ports G1/4 and G1/2
Modular

- » Compact design
- » Available with or without VNR (no return valve)



The take-off blocks, when equipped with a no return valve, allow the use of non lubricated air and should be inserted between the regulator and the lubricator. If mounted as last element, they should be assembled with terminal flanges.

GENERAL DATA

Construction	modular, compact
Materials	zama, NBR, technopolymer
Ports	G1/4 G1/2
Weight	kg 0,232 kg 0,379
Take off ports	G1/4 G1/2
Mounting	in- line or wall mounting (in any position)
Operating temperature	-5°C ÷ 50°C (with the dew point of the fluid lower than 2°C at the min. working temperature)
Finishing	enamelled
Operating pressure	0 ÷ 16 bar
Nominal flow (6 bar ΔP 1bar)	MC1-B = 4080 NI/min MC1-B-VNR = 2350 NI/min MC2-B = 8400 NI/min MC2-B-VNR = 5600 NI/min
Fluid	Compressed air

CODING EXAMPLE

MC	2	-	B	-	VNR
-----------	----------	----------	----------	----------	------------

MC	SERIES
2	SIZE: 1 = G1/4 2 = G1/2
B	B = TAKE OFF BLOCK
VNR	VERSION: = standard VNR = with no return valve

SERIES MC TAKE-OFF BLOCKS

Take off blocks Series MC



BL01 = take-off block
BL02 = take-off block with VNR

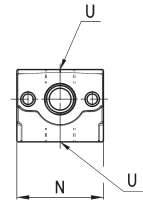
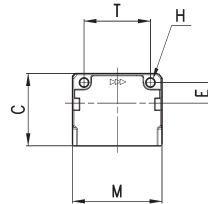
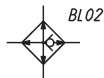

Mod.	C	H	E	M	N	T	U
MC1-B	43	4,5	11	45	45	35	G1/4
MC1-B-VNR	43	4,5	11	45	45	35	G1/4
MC2-B	50	5,5	14	62	60	46	G1/2
MC2-B-VNR	50	5,5	14	62	60	46	G1/2

ACCESSORIES FOR SERIES MC



Terminal flanges
(kit A)

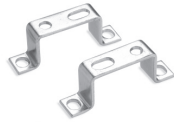

Mounting brackets
(kit B)

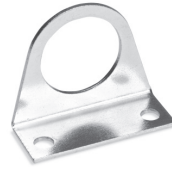

Mounting bracket
Mod. C114-ST

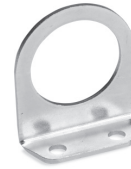

Mounting bracket
Mod. C114-ST/1



Mounting bracket
Mod. C114-ST/2



Mounting bracket
Mod. C238-ST/1



Mounting bracket
Mod. MX2-S



Tie-rods for assembling
(kit C)



Tie-rods for assembling
(kit D)



Screws for assembling
(kit E)



Screws for assembling
(kit F)



Screws for assembling
(kit G)



Assembly O-ring

ACCESSORIES FOR SERIES MC



Systems of rapid connections designed to make mounting easier.

Terminal flanges (kit A)



The kit MC104-FL is supplied with: 1x left flange; 1x right flange; 4x screws M4x14; 2x O-Ring 2068.
Each of the kits MC202-FL and MC238-FL is supplied with: 1x left flange; 1x right flange; 4x screws M5x14; 2x O-Ring 3100.

Materials: painted aluminium flanges, zinc-plated steel screws and NBR O-ring.

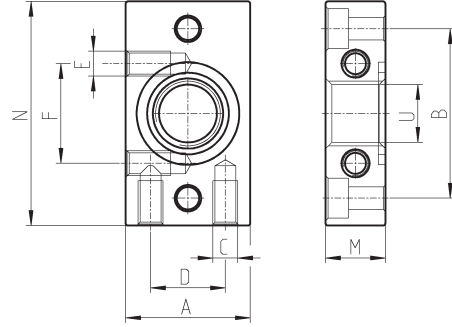

DIMENSIONS										
Mod.	A	B	C	D	E	F	N	M	U	size
MC104-FL	25	34	M5	15	M5	20	45	12	G1/4	1
MC238-FL	35	44,5	M5	20	-	-	60	14	G3/8	2
MC202-FL	35	44,5	M5	20	-	-	60	14	G1/2	2

Mounting bracket for (kit B)

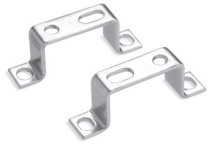

Mounting bracket for terminals 1/4, 3/8, 1/2.

The kit MC104-ST is supplied with:
- 2x terminal brackets
- 4x screws M5x10

Materials: zinc-plated steel brackets and screws.

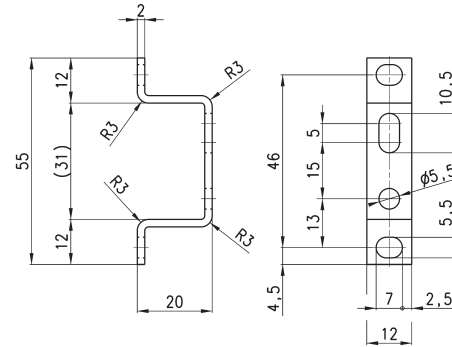

DIMENSIONS
Mod.
MC104-ST

Mounting bracket Mod. C114-ST

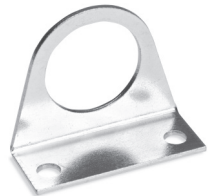

For regulators and filter-regulators (G1/4 - G1/8)

The kit is supplied with:
1x zinc-plated steel bracket.

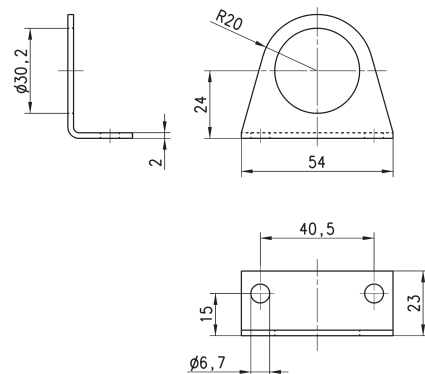

Mod.
C114-ST

Mounting bracket Mod. C114-ST/1



For regulators and filter-regulators (G1/4 - G1/8)

The kit is supplied with 1 zinc-plated steel bracket.

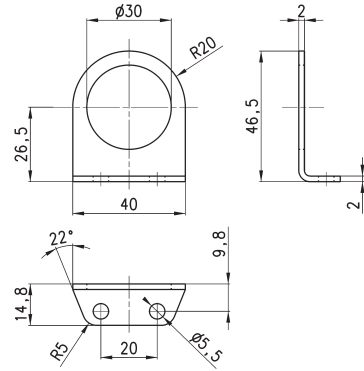

Mod.
C114-ST/1

Mounting bracket Mod. C114-ST/2



For regulators and filter-regulators (G1/4 - G1/8)

The kit is supplied with 1 zinc-plated steel bracket.

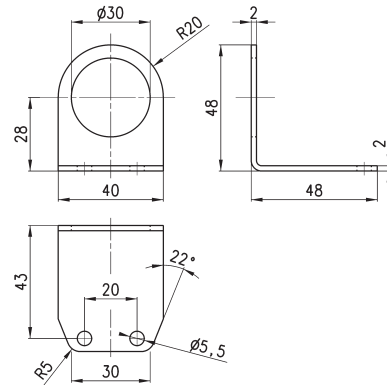

Mod.
C114-ST/2

Mounting bracket Mod. C238-ST/1



for MC238 and MC202

The kit is supplied with:
1 bracket; 2 screws M5X65

Materials: zinc-plated steel bracket and screws.

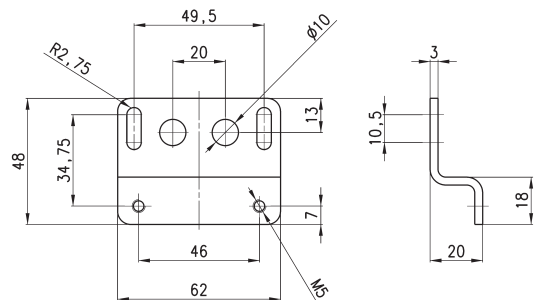

Mod.
C238-ST/1

Fixing bracket Mod. MX2-S



for regulators Mod. MC238 and MC202

The kit is supplied with 1 zinc-plated steel bracket

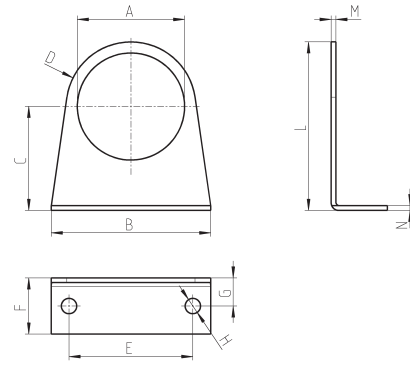

Mod.	A	B	C	D	E	F	G	H	L	M	N
MX2-S	∅ 47,2	73	60,5	R29,5	54	25	15	∅ 6,2	90	2,5	2,5

Tie-rods for assembling (kit C)



The kit MC1-TMF is supplied with:
2 male/female tie-rods; 1 O-ring 2068.
The kit MC2-TMF is supplied with:
2 male/female tie-rods; 1 O-ring 3100.

Materials: nickel-plated steel tie-rods and NBR O-ring.

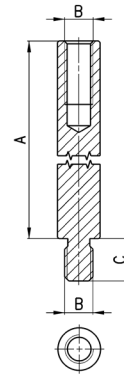

Mod.	A	B	C
MC1-TMF	45	M4	6
MC2-TMF	62	M5	6

Tie-rods for assembling (kit D)



The kit MC1-TFF is supplied with 2 female tie-rods.

The kit MC2-TFF is supplied with 2 female tie-rods.

Materials: nickel-plated steel tie-rods.

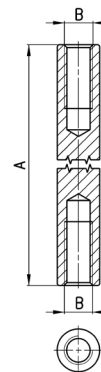

DIMENSIONS			
Mod.	A	B	size
MC1-TFF	44	M4	1
MC2-TFF	61	M5	2

Screws for assembling (kit E)



The kit MC1-VM is supplied with:
2 male screws; 1 O-ring 2068.
The kit MC2-VM is supplied with:
2 male screws; 1 O-ring 3100

Materials: zinc-plated steel screws and NBR O-ring.

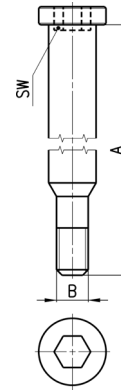

Mod.	A	B	SW	size
MC1-VM	48,5	M4	3	1
MC2-VM	65,5	M5	4	2

Screws for assembling (kit F)



The kit is supplied with: 2 male screws; 2 female screws; 1 O-ring (OR 2068 for MC1-VMF; OR 3100 for MC2-VMF).

Materials: zinc-plated steel male screws, nickel-plated steel female screws and NBR O-ring.

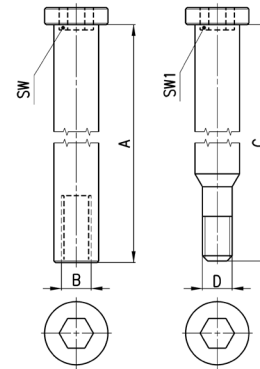

DIMENSIONS							
Mod.	A	B	C	D	SW	SW1	size
MC1-VMF	42	M4	48,5	M4	3	3	1
MC2-VMF	59	M5	68,5	M5	4	4	2

Screws (kit G) to assemble 2 bodies type "M"



The kit MC1-VMD is supplied with:
4 screws M4X10; 4 spacers; 2 O-ring 2068.
The kit MC2-VMD is supplied with:
4 screws M5X12; 4 spacers; 2 O-ring 3100.

Materials: zinc-plated steel screws, brass spacers and NBR O-ring.

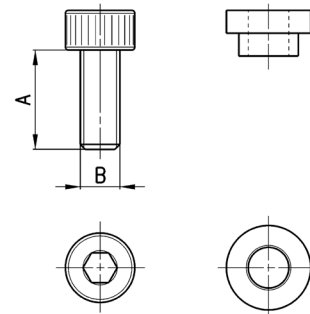

Mod.	A	B	size
MC1-VMD	10	M4	1 *
MC2-VMD	12	M5	2 *

O-ring for assembling

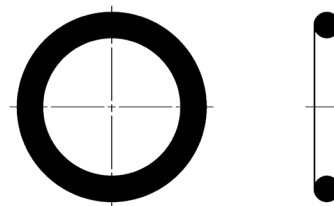

Mod.	O-ring	For assembly
458-33/1	OR 2068	MC104
80-26-11/4T	OR 3100	MC238, MC202

* spare parts only

Series MC assembled FRL

Ports G1/4, G3/8 and G1/2

SERIES MC ASSEMBLED FRL

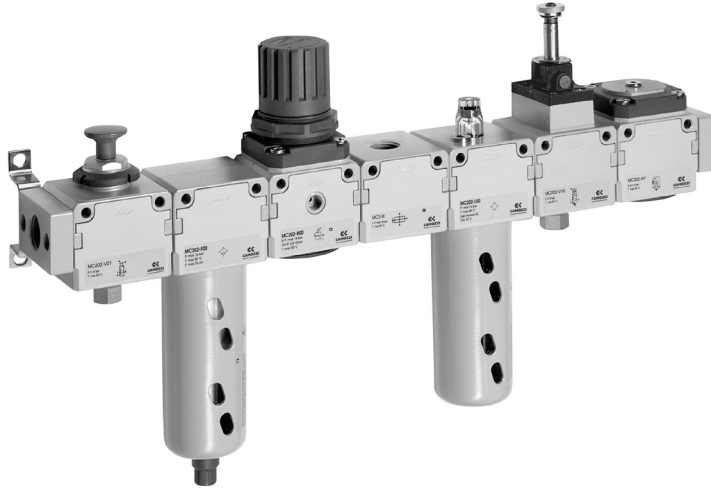

- » Clean design
- » Great modularity
- » Easy maintenance

The FRL Series MC in the assembled version can be easily assembled by means of modular tie rods on which it is possible to mount the single elements without any limits in the composition. The FRL groups Series MC are available already mounted (with a single code).

The connections can be made directly on the elements or on the terminal flanges (Kit A) with the advantage that in case of maintenance the group can be extracted without disconnecting the tubing. The version with flanges is supplied without tie-rods.

GENERAL DATA

Construction	modular, compact
Materials	zama, NBR, technopolymer
Ports	G1/4 - G3/8 - G1/2
Mounting	vertical, in-line or wall-mounting
Operating temperature	-5°C ÷ 50°C at 10 bar (with the dew point of the fluid lower than 2°C at the min. working temperature)
Finish	enamelled
Flow	determined at 6 bar inlet supply with ΔP 1 bar (ΔP 0,5 only for FRL)

COMPOSITION OF THE KITS

- EXAMPLE BODY TYPE [M] with female no through threads: - regulator - filter-regulator - Manifold regulator group, an assembly of more manifold regulators counts as a body type "M".

- EXAMPLE BODY TYPE [P] with through holes:
- filter - lubricator - soft start valve - take off block - isolation valve

The "x" in the codes in the following table refer to the size, see MC Accessories in the section 3/2.44.

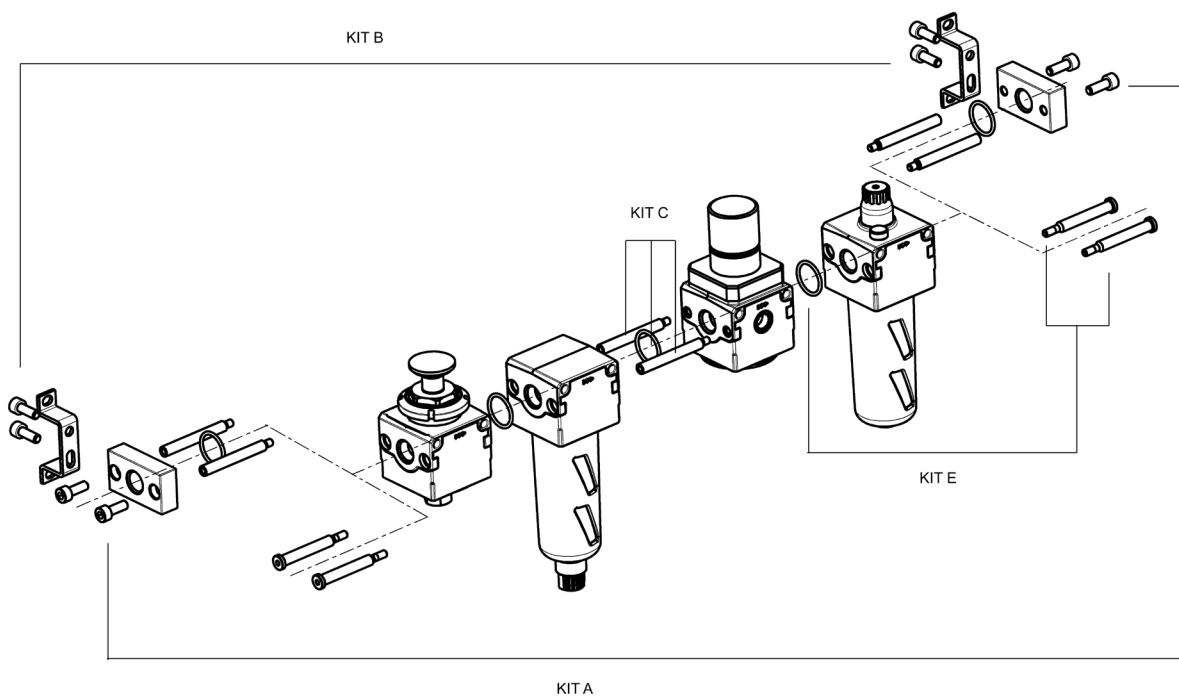

Mod.	Description	Supplied with:
MCxxx-FL	Kit A	1 right flange 1 left flange 4 screws - 2 O-ring
MCxxx-ST	Kit B	2 brackets + 4 screws
MCx-TMF	Kit C	2 tie rods male-female 1 O-ring
MCx-TFF	Kit D	2 tie rods female-female
MCx-VM	Kit E	2 male screws 1 O-ring
MCx-VMF	Kit F	2 male screws 2 female screws 1 O-ring
MCx-VMD	Kit G	4 screws 4 spacers + 2 O-ring To be used on a body type "P" positioned in between two body types "M".

ASSEMBLY EXAMPLE WITH AND WITHOUT TERMINAL FLANGES

- the body types [M] are with female no through threads
- the body types [P] are with through holes

SERIES MC ASSEMBLED FRL

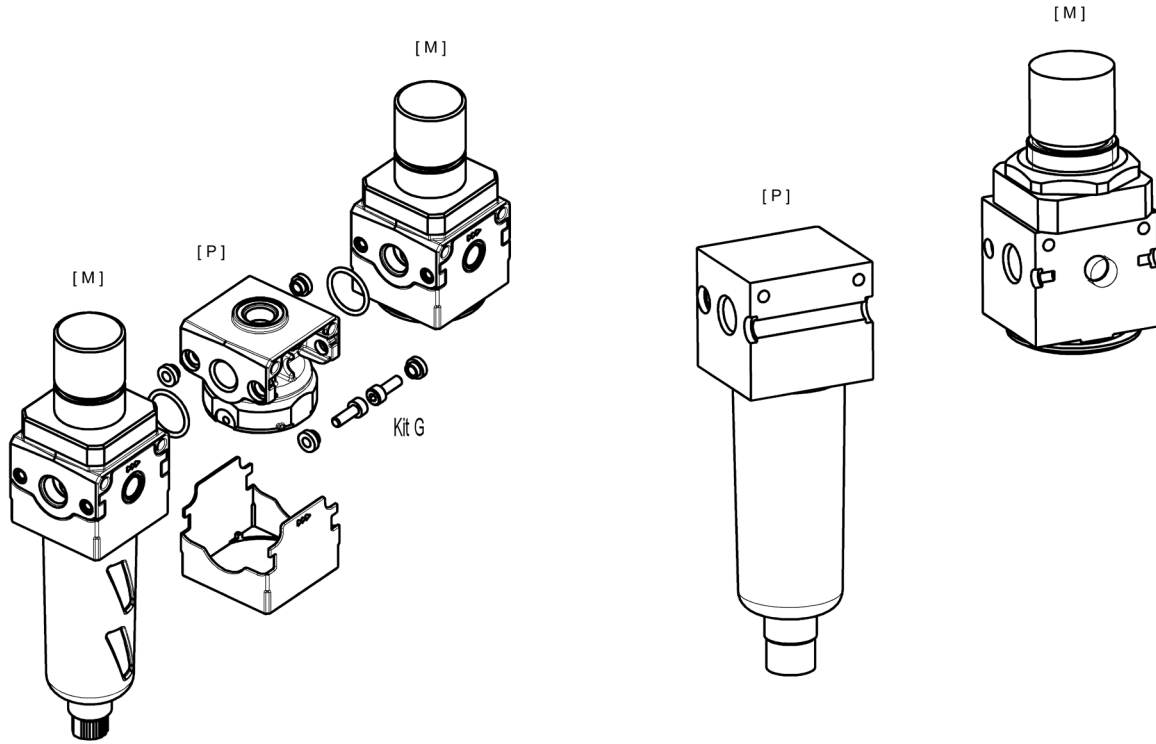

Assembly between types P and M	KIT for ass. without terminal flanges	KIT for ass. with terminal flanges
P + M	1 kit E	1 Kit A + 1 Kit C
M + P	1 kit E	1 Kit A + 1 Kit C
P + P	1 Kit F	1 Kit A + 1 Kit C + 1 Kit D
P + M + P	2 Kit E	1 Kit A + 2 Kit C
P + P + P	1 Kit F + 1 Kit C	1 Kit A + 2 Kit C + 1 Kit D
M + P + P	1 Kit E + 1 Kit C	1 Kit A + 2 Kit C
M + P + M	1 Kit G	1 Kit A + 1 Kit G
P + M + P + P	2 Kit E + 1 Kit C	1 Kit A + 3 Kit C
P + P + M + P + P	2 Kit E + 2 Kit C	1 Kit A + 4 Kit C

CODING EXAMPLE

MC	2	02	-	C	-	5	-	FL
-----------	----------	-----------	----------	----------	----------	----------	----------	-----------

MC	MC = SERIES
2	SIZE 1 = G1/4 2 = G3/8 - G1/2
02	PORT 04 = G1/4 38 = G3/8 02 = G1/2
C	ASSEMBLY GROUP C = D + L E = V01 + D + L FRL = F + R + L GN = D + L + V16 + AV HNA = V01 + D + L + V16 + AV + PRESS NO HNC = V01 + D + L + V16 + AV + PRESS NC N = V01 + D PN = D + V16 + AV QN = V01 + D + V16 + AV TN = V01 + D + L + V16 + AV U = F13 + FB3 (only for 3/8 - 1/2) ZNA = V01 + D + V16 + AV + PRESS NO ZNC = V01 + D + V16 + AV + PRESS NC
5	FILTERING ELEMENT 5 = 5 µm (standard) 25 = 25 µm (upon request)
FL	VERSION FL = with terminal flanges (without brackets)
<p>LEGEND:</p> <p>D = Filter-regulator 0.5-10 bar, semi-automatic-manual drain with relieving, filtering element 5 µm or 25 µm</p> <p>L = Lubricator</p> <p>V01 = 3/2-way manually operated valve</p> <p>F = Filter 5 µm or 25 µm</p> <p>R = Regulator 0.5-10 bar with relieving</p> <p>V16 = 3/2-way electropneumatically operated valve</p> <p>AV = Soft start valve</p> <p>PRESS NO = Pressure switch, Normally Open</p> <p>PRESS NC = Pressure switch, Normally Closed</p> <p>F13 = Filter 5 µm with automatic drain</p> <p>FB3 = Coalescing filter 0.01 µm with automatic drain</p>	

SERIES MC ASSEMBLED FRL

Assembly group C

Components:
Filter-regulator
Lubricator

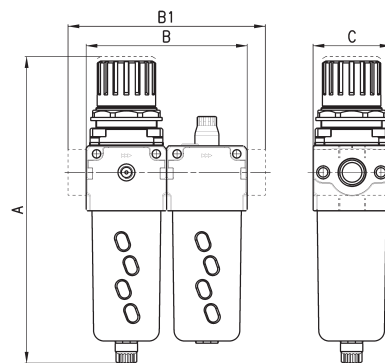
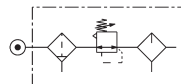

DIMENSIONS					
Mod.	A	B	B1	C	Flow rate (NL/min)
MC104-C-5	193,5	90	-	45	1450
MC238-C-5	256,5	124	-	60	4800
MC202-C-5	256,5	124	-	60	4900
MC104-C-5-FL	193,5	-	114	45	1450
MC238-C-5-FL	256,5	-	152	60	4800
MC202-C-5-FL	256,5	-	152	60	4900

Assembly group E



Components:
Lockable isolation 3/2-way valve
Filter-regulator
Lubricator

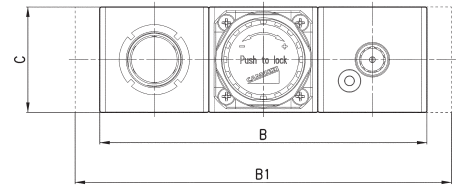
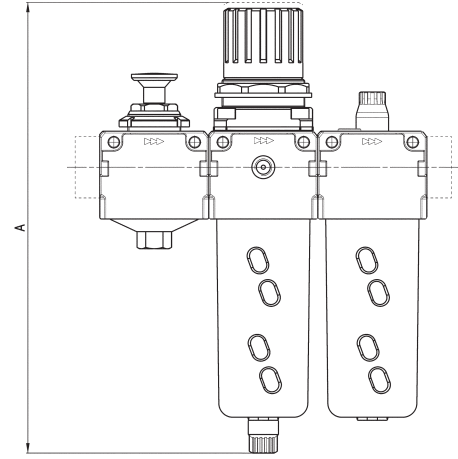

DIMENSIONS					
Mod.	A	B	B1	C	Flow rate (NI/min)
MC104-E-5	193,5	135	-	45	1450
MC238-E-5	256,5	186	-	60	4800
MC202-E-5	256,5	186	-	60	4950
MC104-E-5-FL	193,5	-	159	45	1450
MC238-E-5-FL	256,5	-	214	60	4800
MC202-E-5-FL	256,5	-	214	60	4950

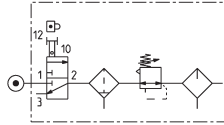

Assembly group FRL



Components:
Filter
Regulator
Lubricator

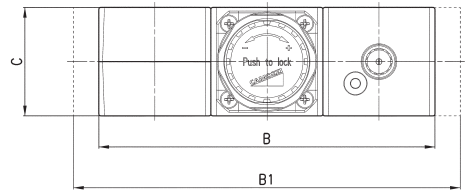
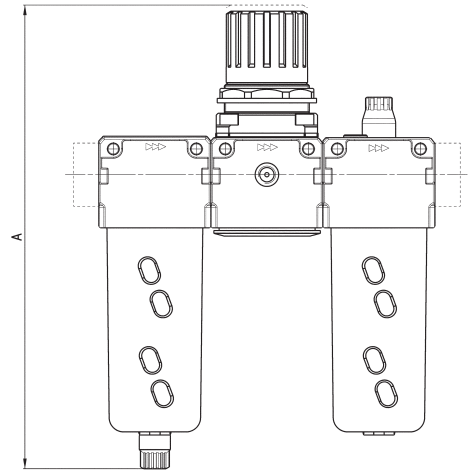

DIMENSIONS					
Mod.	A	B	B1	C	Flow rate (NI/min)
MC104-FRL-5	193	135	-	45	1450
MC238-FRL-5	256,5	186	-	60	4800
MC202-FRL-5	256,5	186	-	60	4900
MC104-FRL-5-FL	193,5	-	159	45	1450
MC238-FRL-5-FL	256,5	-	214	60	4800
MC202-FRL-5-FL	256,5	-	214	60	4900

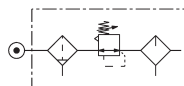

Assembly group GN



Components:
 Filter-regulator
 Lubricator
 Lockable isolation 3/2-way valve
 Soft start valve

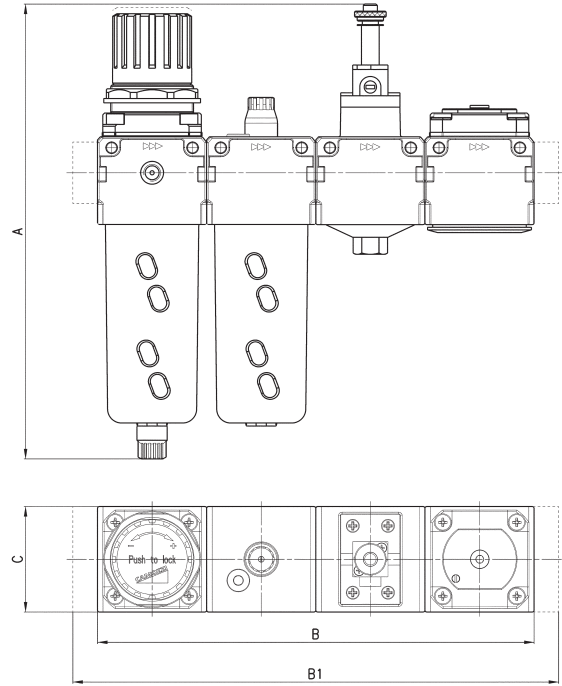

DIMENSIONS					
Mod.	A	B	B1	C	Flow rate (NI/min)
MC104-GN-5	208	180	-	45	1450
MC238-GN-5	259	248	-	60	4800
MC202-GN-5	259	248	-	60	4900
MC104-GN-5-FL	208	-	204	45	1450
MC238-GN-5-FL	259	-	276	60	4800
MC202-GN-5-FL	259	-	276	60	4950

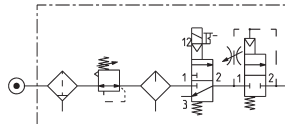

Assembly group HN...



Components:
 Lockable isolation 3/2-way valve
 Filter-regulator
 Lubricator
 Lockable isolation 3/2-way valve
 Soft start valve + pressure switch (NC)

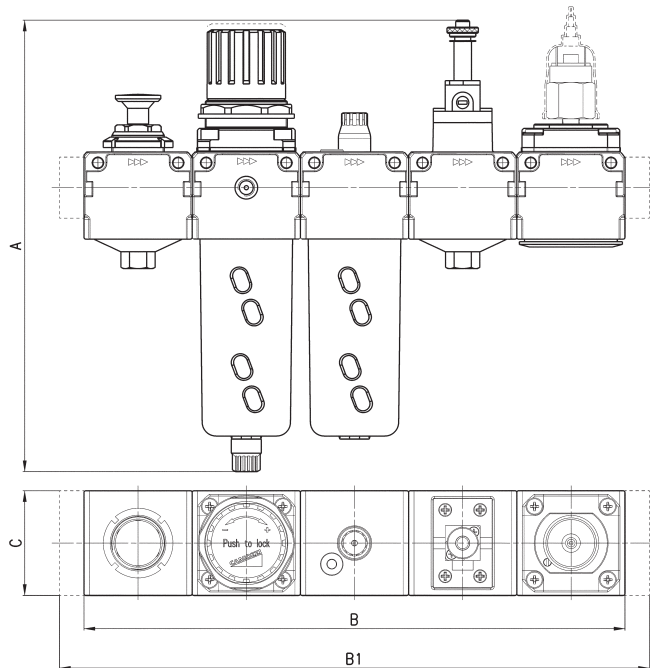

DIMENSIONS					
Mod.	A	B	B1	C	Flow rate (NI/min)
MC104-HN...-5	208	225	-	45	1450
MC238-HN...-5	259	310	-	60	4800
MC202-HN...-5	259	310	-	60	4950
MC104-HN...-5-FL	208	-	249	45	1450
MC238-HN...-5-FL	259	-	338	60	4800
MC202-HN...-5-FL	259	-	338	60	4950

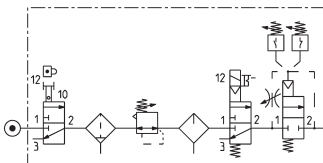

Assembly group N



Components:
Lockable isolation 3/2-way valve
Filter-regulator

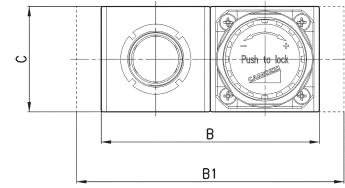
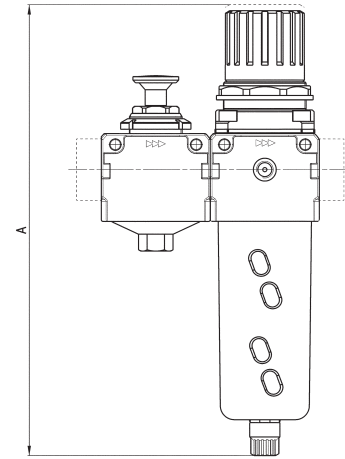

DIMENSIONS					
Mod.	A	B	B1	C	Flow rate (NI/min)
MC104-N-5	193,5	90	-	45	1450
MC238-N-5	256,5	124	-	60	4800
MC202-N-5	256,5	124	-	60	4950
MC104-N-5-FL	193,5	-	114	45	1450
MC238-N-5-FL	256,5	-	152	60	4800
MC202-N-5-FL	256,5	-	152	60	4950

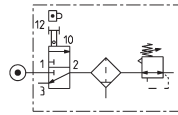

Assembly group PN



Components:
Filter-regulator
Lockable isolation 3/2-way valve
Soft start valve

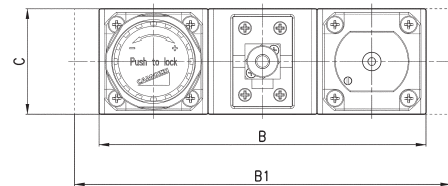
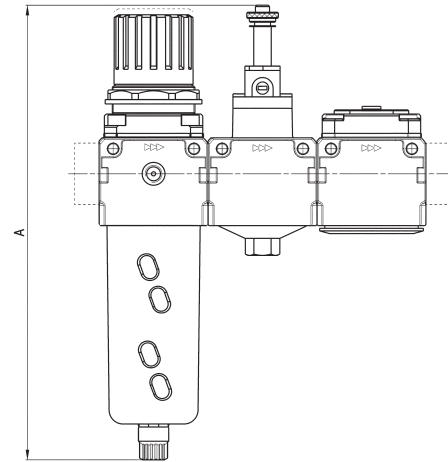

DIMENSIONS					
Mod.	A	B	B1	C	Flow rate (NI/min)
MC104-PN-5	208	135	-	45	1450
MC238-PN-5	259	186	-	60	4800
MC202-PN-5	259	186	-	60	4950
MC104-PN-5-FL	208	-	159	45	1450
MC238-PN-5-FL	259	-	214	60	4800
MC202-PN-5-FL	259	-	214	60	4950

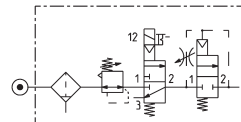

Assembly group QN



Components:
Lockable isolation 3/2-way valve
Filter-regulator
Lockable isolation 3/2-way valve
Soft start valve

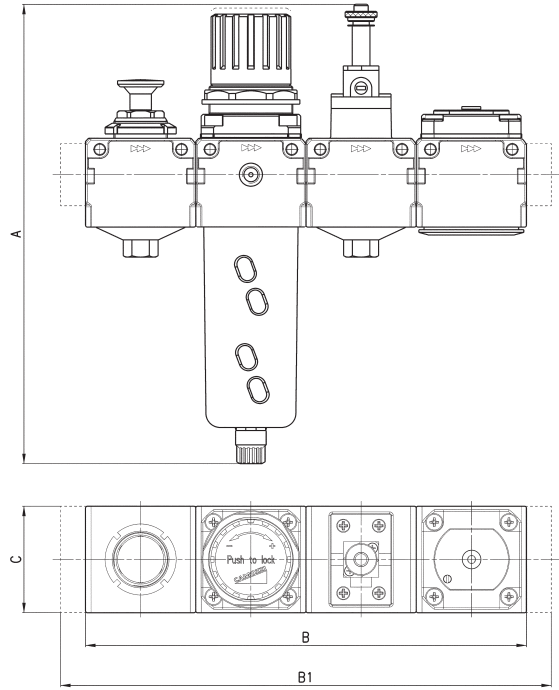

DIMENSIONS					
Mod.	A	B	B1	C	Flow rate (NI/min)
MC104-QN-5	208	180	-	45	1450
MC238-QN-5	259	248	-	60	4800
MC202-QN-5	259	248	-	60	4950
MC104-QN-5-FL	208	-	204	45	1450
MC238-QN-5-FL	259	-	276	60	4800
MC202-QN-5-FL	259	-	276	60	4950

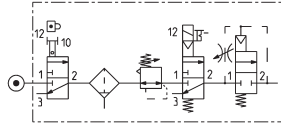

Assembly group TN



Components:
Lockable isolation 3/2-way valve
Filter-regulator
Lubricator
Lockable isolation 3/2-way valve
Soft start valve

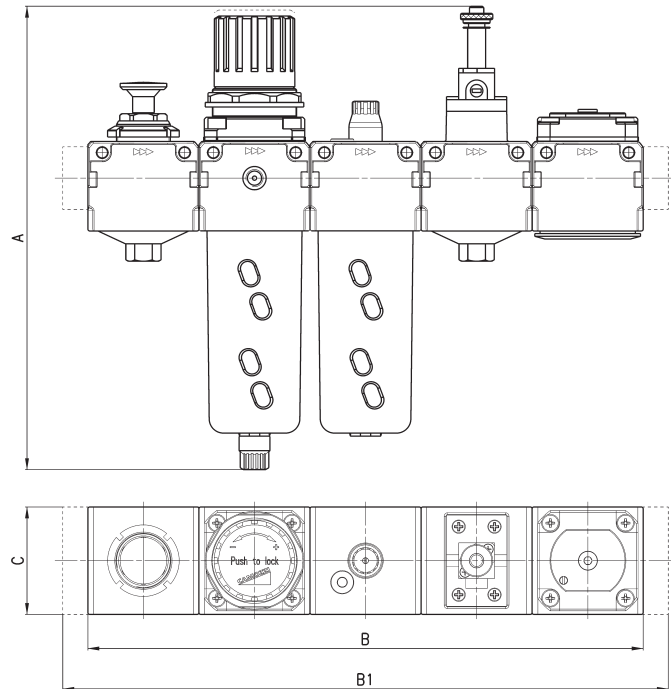

DIMENSIONS					
Mod.	A	B	B1	C	Flow rate (NI/min)
MC104-TN-5	208	225	-	45	1450
MC238-TN-5	259	310	-	60	4800
MC202-TN-5	259	310	-	60	4950
MC104-TN-5-FL	208	-	249	45	1450
MC238-TN-5-FL	259	-	338	60	4800
MC202-TN-5-FL	259	-	338	60	4950

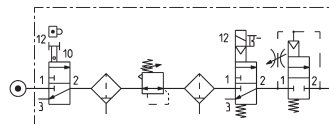

Assembly group U



Components:
Filter
Coalescing filter

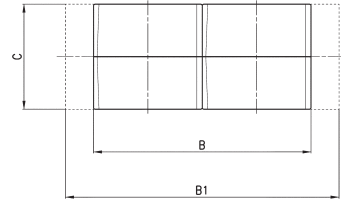
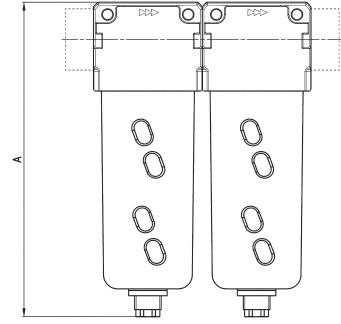

DIMENSIONS					
Mod.	A	B	B1	C	Flow rate (NI/min)
MC238-U-5	180	124	-	60	2050
MC202-U-5	180	124	-	60	2300
MC238-U-5-FL	180	-	152	60	2050
MC202-U-5-FL	180	-	152	60	2300

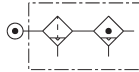

Assembly group ZN...

Components:
Lockable isolation 3/2-way valve
Filter-regulator
Lockable isolation 3/2-way valve
Soft start valve + pressure switch
(NO or NC)

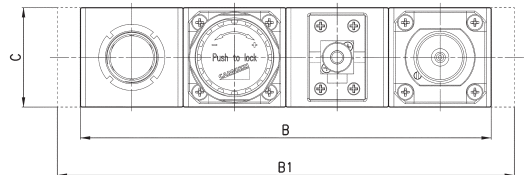
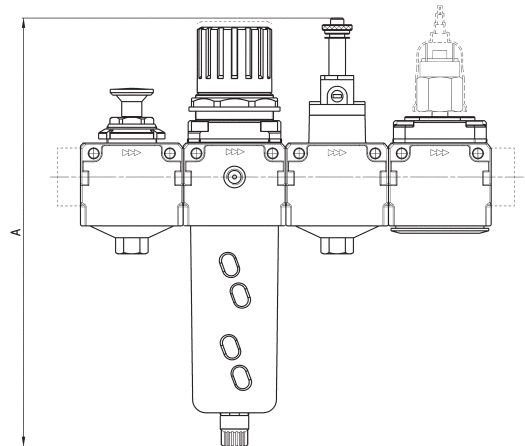

DIMENSIONS					
Mod.	A	B	B1	C	Flow rate (NI/min)
MC104-ZN...-5	208	180	-	45	1450
MC238-ZN...-5	259	248	-	60	4800
MC202-ZN...-5	259	248	-	60	4950
MC104-ZN...-5-FL	208	-	204	45	1450
MC238-ZN...-5-FL	259	-	276	60	4800
MC202-ZN...-5-FL	259	-	276	60	4950

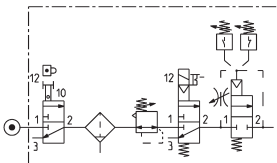

Series MC manifold pressure regulators

Ports G1/4
Modular



- » Minimal pressure decreases
- » Knob with closure
- » Integral return exhaust (relieving)

The manifold pressure regulators with ports G1/4 are available with a second pressure relieving and can be in-line or panel mounted.

GENERAL DATA

Construction	compact modular, diaphragm type
Materials	zama, NBR, technopolymer
Port	G1/4
Weight	kg 0,320
Pressure gauge ports / outlet	G1/8
Mounting	in-line, wall or panel mounting (in any position)
Operating temperature	-5°C ÷ 50°C (with the dew point of the fluid lower than 2°C at the min. working temperature)
Finishing	enamelled
Inlet pressure	0 ÷ 16 bar
Outlet pressure	0.5 ÷ 10 bar; 0.5 ÷ 2 bar; 0.5 ÷ 4 bar; 0.5 ÷ 7 bar
Flow	see the FLOW DIAGRAM on the following page
Secondary pressure relieving	standard

CODING EXAMPLE

MC	1	04	-	M	T	0	2	-	■	-	●
----	---	----	---	---	---	---	---	---	---	---	---

MC	SERIES
1	SIZE: 1 = G1/4
04	PORT: 04 = G1/4
M	MANIFOLD REGULATOR
T	OPERATING PRESSURE 0 = 0.5 ÷ 10 bar (standard) 1 = 0.5 ÷ 4 bar 2 = 0.5 ÷ 2 bar 7 = 0.5 ÷ 7 bar
0	CONSTRUCTION: 0 = self-relieving (standard) 1 = non-relieving 5 = precise relieving
2	PRESSURE GAUGE = without pressure gauge (standard) 1 = with pressure gauge 0-2.5 with working pressure 0.5 ÷ 2 bar 2 = with pressure gauge 0-6 with working pressure 0.5 ÷ 4 bar 3 = with pressure gauge 0-10 with working pressure 0.5 ÷ 7 bar 4 = with pressure gauge 0-12 with working pressure 0.5 ÷ 10 bar
<p>** NOTE: IF THE REGULATOR IS CALIBRATED OR LOCKED, AFTER THE PORTS ADD THE INLET PRESSURE "■" AND THE OUTLET PRESSURE "●"</p> <p>INLET PRESSURE: ■ = enter the SUPPLY pressure value</p> <p>OUTLET PRESSURE: ● = enter the OUTLET pressure value for the LOCKED regulator or the maximum value of the ADJUSTABLE pressure for the CALIBRATED regulator</p> <p>Example of a calibrated regulator with Inlet Pressure = 6.3 bar and Outlet Pressure = 4.5 bar Complete part number: MC104-MT03-6.3-4.5</p> <p>** the pressure gauges are supplied disassembly for size 1 pressure gauge mod. M043-P. for size 2 pressure gauge mod.M053-P.</p>	

SERIES MC MANIFOLD PRESSURE REGULATORS

FLOW DIAGRAM

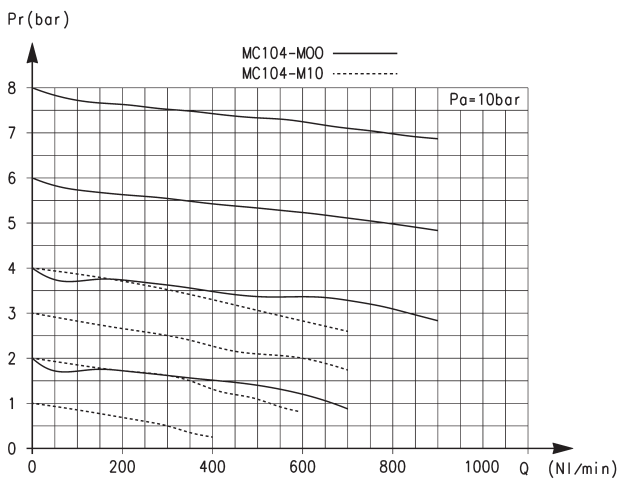

Flow diagram for model: MC104-M00

P_a = Inlet pressure (bar)

P_r = Regulated pressure (bar)

Q = Flow (NL/min)

Assembly

EXAMPLE BODY TYPE [H] :

Manifold regulator with through holes on top (used to mount the manifold regulators to each other).

N.B.: Once a group of manifolds has been assembled, it can be inserted in a FRL group. In this case the manifold regulator assembly alone would be defined as body type M.

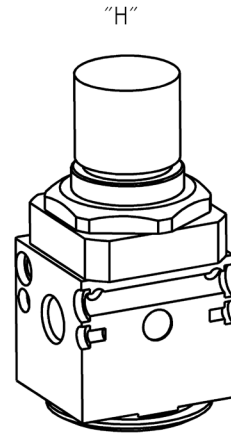

Assembly kits

- Kit A: 1 right flange + 1 left flange + 4 screws + 2 O-ring.
- Kit B: 2 brackets + 4 screws.
- Kit C: 2 tie rods male-female + 1 O-ring.
- Kit D: 2 tie rods female-female.
- Kit E: 2 male screws + 1 O-ring.
- Kit F: 2 male screws + 2 female screws + 1 O-ring.
- Kit G: 4 screws + 4 spacers + 2 O-ring, to be used on a body type "P" positioned between two body types "M".

N.B. for configurations which differ from the ones described, you can only add only bodies type "H" and for every part added you should add a Kit "C".

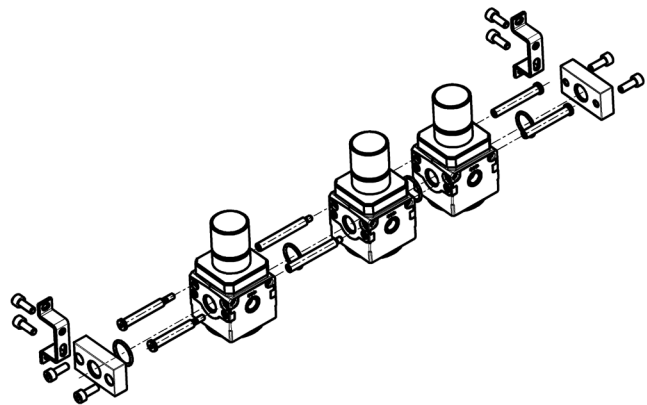

Manifold pressure regulators Series MC

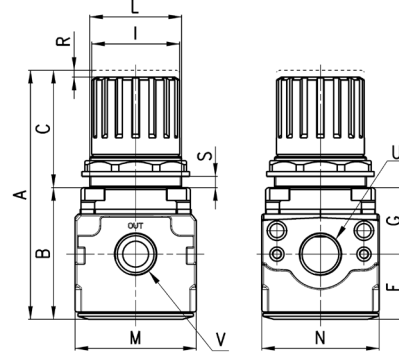

DIMENSIONS													
Mod.	A	B	C	F	G	I	L	M	N	R	S	U	V
MC104-M00	94	55	39	28	28	28	30X1,5	45	45	3	0÷6	G1/4	G1/8

Pneumatic symbols

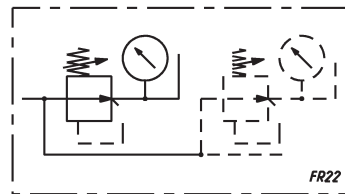
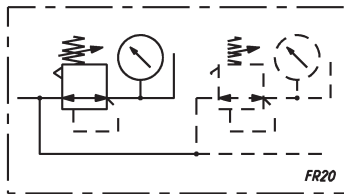
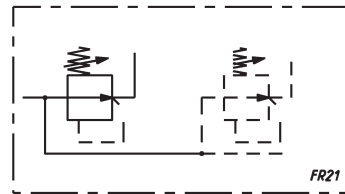
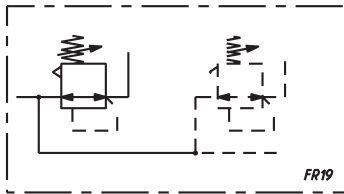

FR19 = Manifold regulator with relieving and without pressure gauge
FR20 = Manifold regulator with relieving and pressure gauge

FR21 = Manifold regulator without relieving and pressure gauge
FR22 = Manifold regulator without relieving and with pressure gauge

Series MD filters

Ports with interchangeable cartridges: threaded (1/8, 1/4, 3/8) or integrated with super-rapid fitting for tube with \varnothing 6, 8 and 10 mm.

Modular assembly

Bowl with technopolymer cover and bayonet-type mounting



- » Removal of impurities and condensate
- » Visual blockage indicator
- » Condensate drain options: semi-automatic manual, automatic protected depressurisation, direct G1/8 exhaust
- » Bowl locking system reducing the risk of accidents
- » Additional air intakes with the same characteristics of the outlet air (line)

The Series MD air preparation product line is characterized by a modern and linear design as well as high performance. The technopolymer structure has allowed to create a simplified, product, lightweight and robust at the same time.

Thanks to the solution adopted for the pneumatic connection, it is possible to equip the same element with interchangeable cartridges that can either be threaded, or with an integrated super-rapid fitting, both types available in different sizes. Intermediate cartridges can be also integrated to join multiple functions or with derivation to draw air. An additional air intake, with the same characteristic of the outlet air, is available on the front side and on the rear one. This intake can be used by utilities with limited consumption.

GENERAL DATA

Construction	modular, compact with filtering element in HDPE
Materials	see TABLE OF MATERIALS on the following page
Ports	with interchangeable cartridges: 1/8, 1/4 and 3/8 threaded or integrated with super-rapid fitting for tube with diameters of 6, 8 and 10 mm
Condensate capacity	24 cm ³
Mounting	in-line; wall-mounting by means of through holes in the body or with a support bracket; panel mounting
Operating temperature	-5°C ÷ 50°C up to 16 bar (with the dew point of the fluid lower than 2°C at the min. working temperature)
Condensate drain	semi-automatic manual, automatic, protected depressurisation, direct G1/8 exhaust
Quality of delivered air according to ISO 8573-1 2010	Class 6.8.4 with 5 µm filtering element Class 7.8.4 with 25 µm filtering element
Inlet pressure	0.3 ÷ 16 bar (with automatic drain 1 ÷ 9 bar)
Exit pressure	0.5 ÷ 2bar 0.5 ÷ 4bar 0.5 ÷ 7bar 0.5 ÷ 10bar
Nominal flow	see FLOW DIAGRAMS on the following pages

CODING EXAMPLE

MD	1	-	F	0	0	0	-	1/8
-----------	----------	----------	----------	----------	----------	----------	----------	------------

MD	SERIES
1	DIMENSION: 1 = 42 mm
F	FILTER
0	FILTERING ELEMENT (further details in the dedicated section): 0 = 25 µm 1 = 5 µm
0	DRAINING OF CONDENSATE (further details in the dedicated section): 0 = semiautomatic-manual drain 3 = automatic drain 5 = protected depressurisation 8 = direct G1/8 exhaust
0	VISUAL BLOCKAGE INDICATOR: 0 = not present 1 = present
1/8	PORTS (IN - OUT)*: = without cartridges 1/8 = G1/8 1/4 = G1/4 3/8 = G3/8 6 = tube Ø6 8 = tube Ø8 10 = tube Ø10 * NOTE: if the inlet (IN) cartridge is different from the outlet (OUT) cartridge, both dimensions shall be indicated. Example: MD1-F000-1/4-10

SERIES MD FILTERS

Filters Series MD - materials

A = filter
B = filter with visual blockage indicator

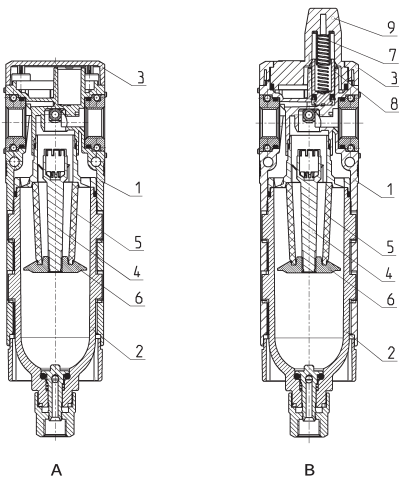

PARTS	MATERIALS
1 = Body	Polyamide
2 = Tank	Polycarbonate
3 = Covering	Polyamide
4 = Valve-guide	Polyacetal
5 = Filtering element	Polyethylene
6 = Separation deflector	Polyacetal
7 = Upper spring	Stainless steel
8 = Piston	Anodized aluminium
9 = Visual blockage indicator	Polycarbonate
Seals	NBR

FLOW DIAGRAMS for models with 25 µm filtering element

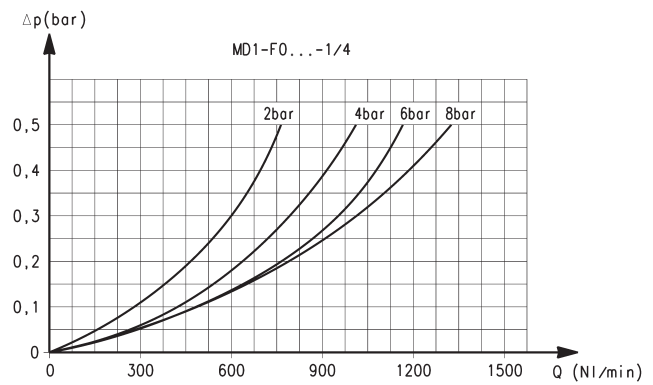
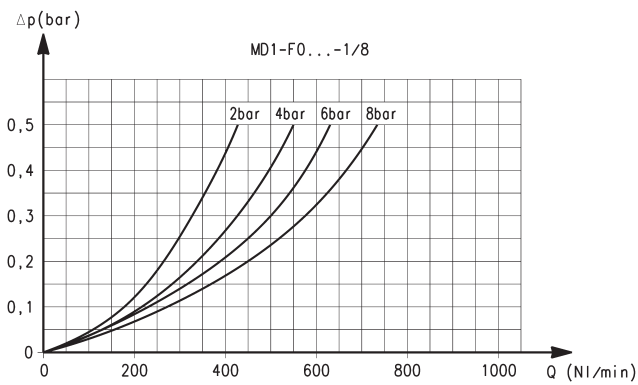

Ports with interchangeable 1/8 threaded cartridges

Δp = Pressure drop (bar)
Q = Flow (NL/min)

Ports with interchangeable 1/4 threaded cartridges

Δp = Pressure drop (bar)
Q = Flow (NL/min)

FLOW DIAGRAM

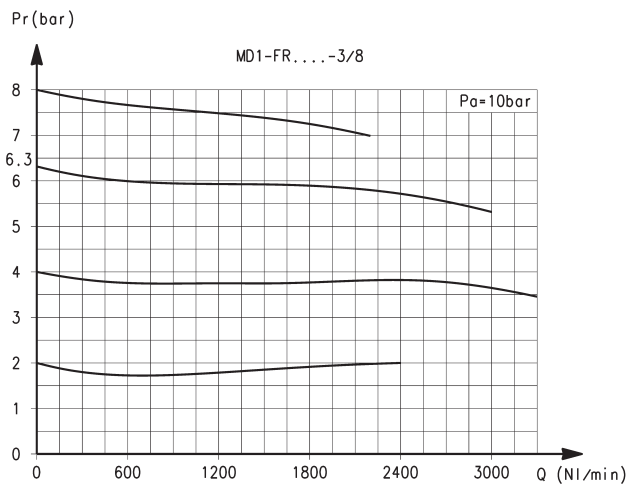

Ports with interchangeable G3/8 threaded cartridges

Pr = Regulated pressure (bar)
Q = Flow (NL/min)

Pa = Inlet pressure (bar)

N.B: The version with automatic exhaust has a flow reduction of max

FLOW DIAGRAMS for models with 5 µm filtering element

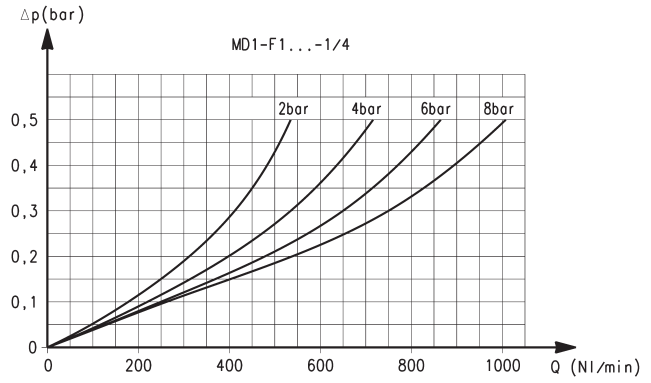
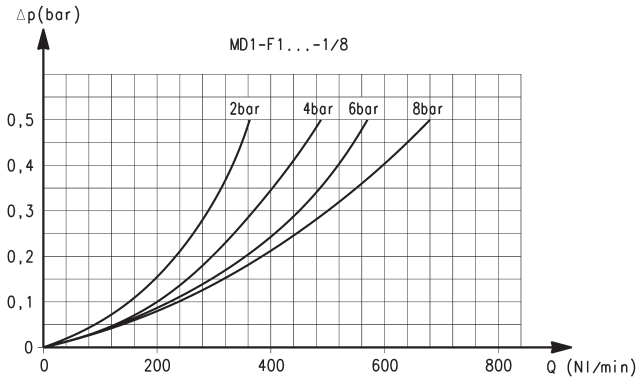

Ports with interchangeable 1/8 threaded cartridges

Δp = Pressure drop (bar)
Q = Flow (NL/min)

Ports with interchangeable 1/4 threaded cartridges

Δp = Pressure drop (bar)
Q = Flow (NL/min)

FLOW DIAGRAM for models with 5 µm filtering element

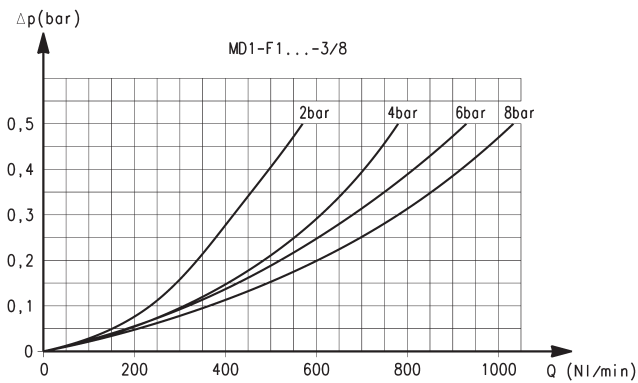

Ports with interchangeable 3/8 threaded cartridges

Δp = Pressure drop (bar)
Q = Flow (NL/min)

N.B The version with automatic exhaust has a flow reduction of max 10%

Series MD filters - dimensions



FT01 = filter with direct G1/8 exhaust
 FT02 = filter with semi-automatic manual drain
 FT03 = filter with automatic/depressuring drain

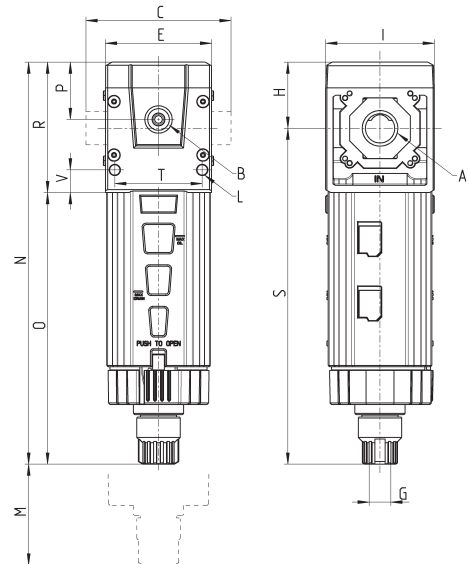
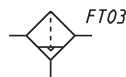
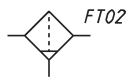
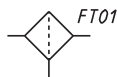

DIMENSIONS																	
Mod.	A	B	C	E	G	H	I	L	M	N	O	P	R	S	T	V	Weight (Kg)
MD1-F000	-	G1/8	42	42	G1/8	26.2	43	Ø4	90	159.4	107.7	22.7	51.7	133.2	34.6	9	0.2
MD1-F000-1/8	G1/8	G1/8	42	42	G1/8	26.2	43	Ø4	90	159.4	107.7	22.7	51.7	133.2	34.6	9	0.2
MD1-F000-1/4	G1/4	G1/8	42	42	G1/8	26.2	43	Ø4	90	159.4	107.7	22.7	51.7	133.2	34.6	9	0.2
MD1-F000-3/8	G3/8	G1/8	42	42	G1/8	26.2	43	Ø4	90	159.4	107.7	22.7	51.7	133.2	34.6	9	0.2
MD1-F000-6	Ø6	G1/8	47	42	G1/8	26.2	43	Ø4	90	159.4	107.7	22.7	51.7	133.2	34.6	9	0.2
MD1-F000-8	Ø8	G1/8	62	42	G1/8	26.2	43	Ø4	90	159.4	107.7	22.7	51.7	133.2	34.6	9	0.2
MD1-F000-10	Ø10	G1/8	67	42	G1/8	26.2	43	Ø4	90	159.4	107.7	22.7	51.7	133.2	34.6	9	0.2
MD1-F030	-	G1/8	42	42	M10x1	26.2	43	Ø4	90	149	97.4	22.7	51.7	122.9	34.6	9	0.2

Series MD filters with visual blockage indicator - dimensions



FT05 = filter with direct G1/8 exhaust and visual blockage indicator
 FT06 = filter with semi-automatic manual drain and visual blockage indicator
 FT07 = filter with automatic/depressuring drain and visual blockage indicator

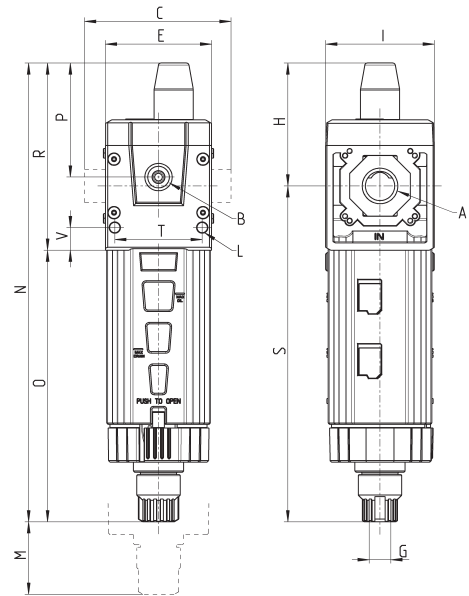
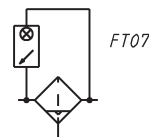
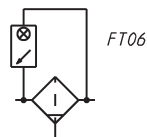
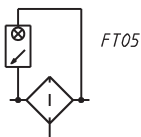

DIMENSIONS																	
Mod.	A	B	C	E	G	H	I	L	M	N	O	P	R	S	T	V	Weight (Kg)
MD1-F001	-	G1/8	42	42	G1/8	48.7	43	Ø4	90	181.9	107.7	45.2	74.2	133.2	34.6	9	0.2
MD1-F001-1/8	G1/8	G1/8	42	42	G1/8	48.7	43	Ø4	90	181.9	107.7	45.2	74.2	133.2	34.6	9	0.2
MD1-F001-1/4	G1/4	G1/8	42	42	G1/8	48.7	43	Ø4	90	181.9	107.7	45.2	74.2	133.2	34.6	9	0.2
MD1-F001-3/8	G3/8	G1/8	42	42	G1/8	48.7	43	Ø4	90	181.9	107.7	45.2	74.2	133.2	34.6	9	0.2
MD1-F001-6	Ø6	G1/8	47	42	G1/8	48.7	43	Ø4	90	181.9	107.7	45.2	74.2	133.2	34.6	9	0.2
MD1-F001-8	Ø8	G1/8	62	42	G1/8	48.7	43	Ø4	90	181.9	107.7	45.2	74.2	133.2	34.6	9	0.2
MD1-F001-10	Ø10	G1/8	67	42	G1/8	48.7	43	Ø4	90	181.9	107.7	45.2	74.2	133.2	34.6	9	0.2
MD1-F031	-	G1/8	42	42	M10x1	48.7	43	Ø4	90	171.5	97.4	45.2	74.2	122.9	34.6	9	0.2

Series MD coalescing filters

Ports with interchangeable cartridges: threaded (1/8, 1/4, 3/8) or integrated with super-rapid fitting for tube with Ø 6, 8 and 10 mm.

Modular assembly

Bowl with technopolymer cover and bayonet-type mounting



- » High performance and high purity compressed air
- » Air quality according to ISO 8573-1:2010 standard, Classes 1.8.1 and 2.8.2
- » Visual blockage indicator
- » Condensate drain options: semi-automatic manual, automatic protected depressurisation, direct G1/8 exhaust
- » Bowl locking system reducing the risk of accidents
- » Additional air intakes with the same characteristics of the inlet air (line)

The coalescing filter is a fine oil separator filter that removes the solids with dimensions from 0.1 to 5 µm and oil vapours with a concentration from 0.01 to 0.1 mg/m³. For a correct functioning they require a pre-filtering. Given the characteristic of this filter, it is recommended to replace the filter element at least every 12 months or 8000 working hours.

Thanks to the solution adopted for the pneumatic connection, it is possible to equip the same element with interchangeable cartridges that can either be threaded, or with an integrated super-rapid fitting, both types available in different sizes. Intermediate cartridges can be also integrated to join multiple functions or with derivation to draw air. An additional air intake, with the same characteristic of the outlet air, is available on the front side and on the rear one. This intake can be used by utilities with limited consumption.

GENERAL DATA

Construction	modular, compact with filtering element in BOROSILICATE	
Materials	see TABLE OF MATERIALS on the following page	
Ports	with interchangeable cartridges: 1/8, 1/4 and 3/8 threaded or integrated with super-rapid fitting for tube with Ø 6, 8 and 10 mm	
Condensate capacity	24 cm ³	
Fixing	vertical in-line; wall-mounting by means of through holes in the body or with a support bracket	
Operating temperature	-5°C ÷ 50°C up to 16 bar	
Condensate drain	semi-automatic manual, automatic protected depressurisation, direct G1/8 exhaust	
Quality of delivered air according to ISO 8573-1:2010	Class 2.8.2 with 1 µm filtering element (pre-filtering with Class 6.8.4 is recommended) Classe 1.8.1 with 0.01 µm filtering element (pre-filtering with Classe 2.8.2 is recommended)	
Operating pressure	0.3 ÷ 16 bar	
Nominal flow	see FLOW DIAGRAMS on the following pages	
Oil retain efficiency	99.80% (0.01µm)	97% (1µm)
Particles retain efficiency	99.99999% (0.01µm)	99.999% (1µm)
Fluid	compressed air	

CODING EXAMPLE

MD	1	-	FC	0	0	0	-	1/8
-----------	----------	----------	-----------	----------	----------	----------	----------	------------

MD	SERIES
1	DIMENSION: 1 = 42 mm
FC	COALESCING FILTER
0	FILTERING ELEMENT (further details in the dedicated section): 0 = 0,01 µm 1 = 1 µm
0	DRAINING OF CONDENSATE (further details in the dedicated section): 0 = semiautomatic-manual drain 5 = automatic drain, protected depressurisation 8 = direct G1/8 exhaust
0	VISUAL BLOCKAGE INDICATOR: 0 = not present 1 = present
1/8	PORTS (IN - OUT)*: = without cartridges 1/8 = G1/8 1/4 = G1/4 3/8 = G3/8 6 = tube Ø6 8 = tube Ø8 10 = tube Ø10 * NOTE: if the inlet (IN) cartridge is different from the outlet (OUT) cartridge, both dimensions shall be indicated. Example: MD1-FC000-1/4-10

SERIES MD COALESCING FILTERS

Series MD coalescing filters - materials

A = filter
B = filter with visual blockage indicator

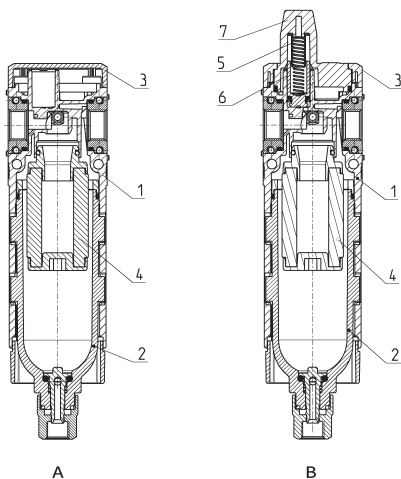

PARTS	MATERIALS
1 = Body	Polyamide
2 = Tank	Polycarbonate
3 = Covering	Polyamide
4 = Filtering element	Borosilicate
5 = Upper spring	Stainless steel
6 = Piston	Anodized aluminium
7 = Visual blockage indicator	Polycarbonate
Seals	NBR

FLOW DIAGRAMS for models with 1 μm filtering element

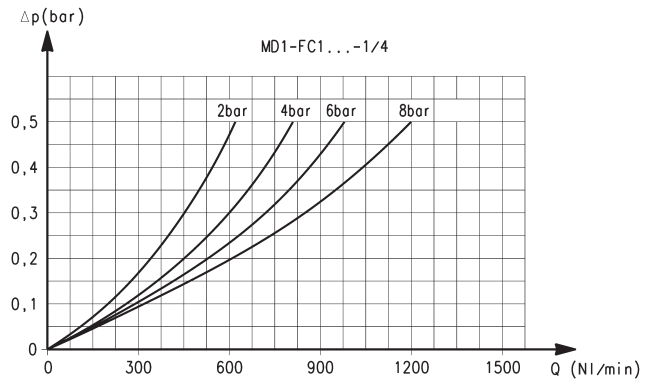
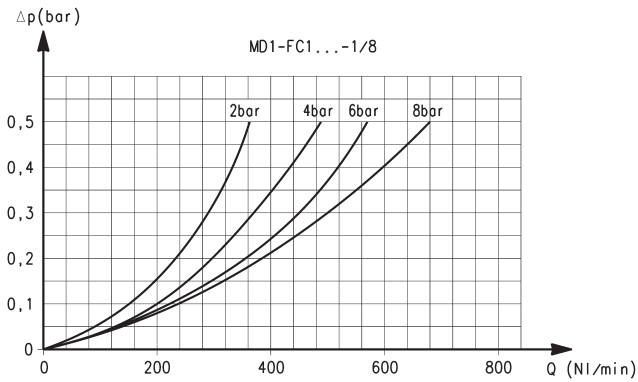

Ports with interchangeable 1/8 threaded cartridges

Δp = Pressure drop (bar)
Q = Flow (NL/min)

Ports with interchangeable 1/4 threaded cartridges

Δp = Pressure drop (bar)
Q = Flow (NL/min)

FLOW DIAGRAM for models with 1 μm filtering element

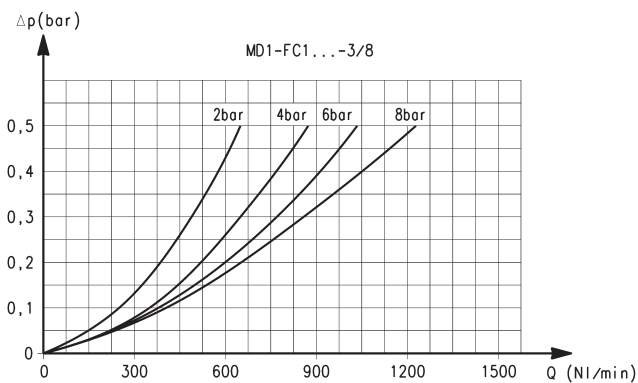

Ports with interchangeable 3/8 threaded cartridges

Δp = Pressure drop (bar)
Q = Flow (NL/min)

FLOW DIAGRAMS for models with 0.01 µm filtering element

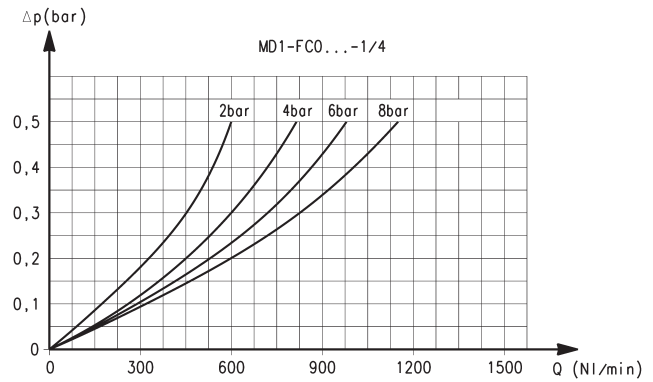
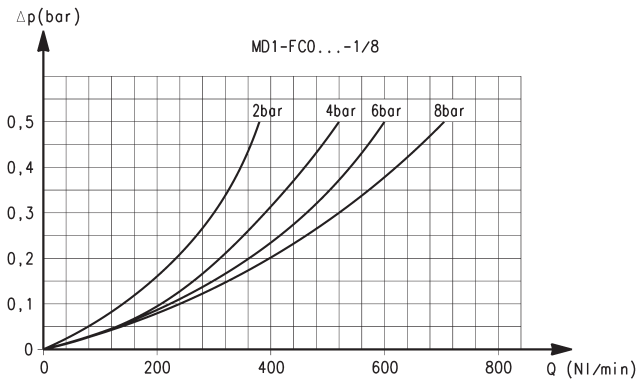

Ports with interchangeable 1/8 threaded cartridges

Δp = Pressure drop (bar)
Q = Flow (NL/min)

Ports with interchangeable 1/4 threaded cartridges

Δp = Pressure drop (bar)
Q = Flow (NL/min)

FLOW DIAGRAM for models with 0.01 µm filtering element

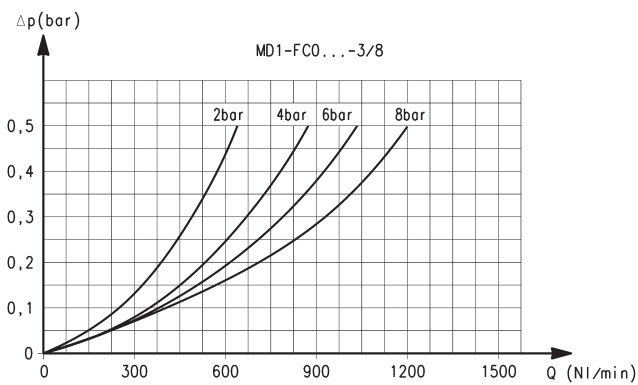

Ports with interchangeable 3/8 threaded cartridges

Δp = Pressure drop (bar)
Q = Flow (NL/min)

Series MD coalescing filters - dimensions



- FA01 = coalescing filter with direct G1/8 exhaust
- FA02 = coalescing filter with semi-automatic manual drain
- FA03 = coalescing filter with automatic/depressuring drain

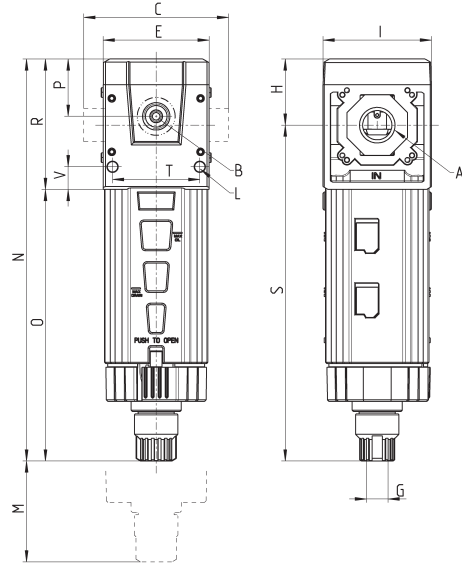
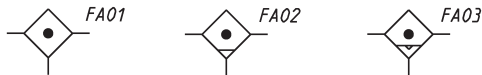

DIMENSIONS																	
Mod.	A	B	C	E	G	H	I	L	M	N	O	P	R	S	T	V	Weight (Kg)
MD1-FC000	-	G1/8	42	42	G1/8	26.2	43	Ø4	90	159.4	107.7	22.7	51.7	133.2	34.6	9	0.2
MD1-FC000-1/8	G1/8	G1/8	42	42	G1/8	26.2	43	Ø4	90	159.4	107.7	22.7	51.7	133.2	34.6	9	0.2
MD1-FC000-1/4	G1/4	G1/8	42	42	G1/8	26.2	43	Ø4	90	159.4	107.7	22.7	51.7	133.2	34.6	9	0.2
MD1-FC000-3/8	G3/8	G1/8	42	42	G1/8	26.2	43	Ø4	90	159.4	107.7	22.7	51.7	133.2	34.6	9	0.2
MD1-FC000-6	Ø6	G1/8	47	42	G1/8	26.2	43	Ø4	90	159.4	107.7	22.7	51.7	133.2	34.6	9	0.2
MD1-FC000-8	Ø8	G1/8	62	42	G1/8	26.2	43	Ø4	90	159.4	107.7	22.7	51.7	133.2	34.6	9	0.2
MD1-FC000-10	Ø10	G1/8	67	42	G1/8	26.2	43	Ø4	90	159.4	107.7	22.7	51.7	133.2	34.6	9	0.2

Series MD coalescing filters with visual indicator - dimensions



- FA04 = coalescing filter with direct G1/8 exhaust and visual blockage indicator
- FA05 = coalescing filter with semi-automatic manual drain and visual blockage indicator
- FA06 = coalescing filter with automatic/depressuring drain and visual blockage indicator

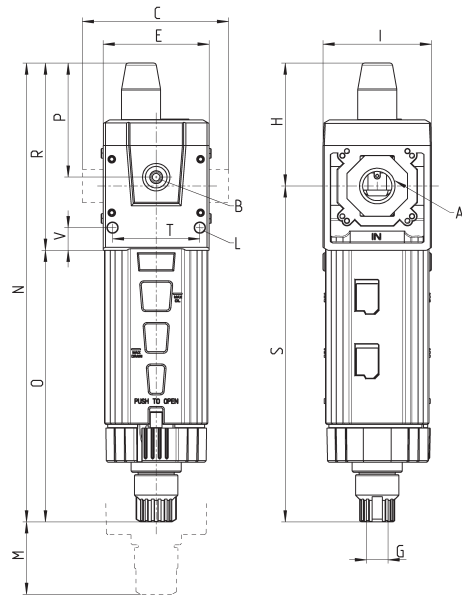
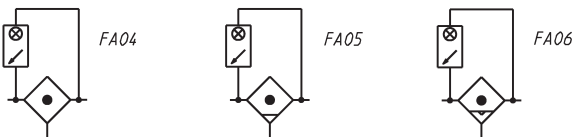

DIMENSIONS																	
Mod.	A	B	C	E	G	H	I	L	M	N	O	P	R	S	T	V	Weight (Kg)
MD1-FC001	-	G1/8	42	42	G1/8	48.7	43	Ø4	90	181.9	107.7	45.2	74.2	133.2	34.6	9	0.2
MD1-FC001-1/8	G1/8	G1/8	42	42	G1/8	48.7	43	Ø4	90	181.9	107.7	45.2	74.2	133.2	34.6	9	0.2
MD1-FC001-1/4	G1/4	G1/8	42	42	G1/8	48.7	43	Ø4	90	181.9	107.7	45.2	74.2	133.2	34.6	9	0.2
MD1-FC001-3/8	G3/8	G1/8	42	42	G1/8	48.7	43	Ø4	90	181.9	107.7	45.2	74.2	133.2	34.6	9	0.2
MD1-FC001-6	Ø6	G1/8	47	42	G1/8	48.7	43	Ø4	90	181.9	107.7	45.2	74.2	133.2	34.6	9	0.2
MD1-FC001-8	Ø8	G1/8	62	42	G1/8	48.7	43	Ø4	90	181.9	107.7	45.2	74.2	133.2	34.6	9	0.2
MD1-FC001-10	Ø10	G1/8	67	42	G1/8	48.7	43	Ø4	90	181.9	107.7	45.2	74.2	133.2	34.6	9	0.2

Series MD activated carbon filters

Ports with interchangeable cartridges: threaded (1/8, 1/4, 3/8) or integrated with super-rapid fitting for tube with \varnothing 6, 8 and 10 mm

Modular assembly

Bowl with technopolymer cover and bayonet-type mounting



- » Removal of oil, liquid and gaseous components from compressed air through the active carbons
- » Air quality in compliance with ISO 8573-1 standard, Class 1.7.1
- » Visual blockage indicator
- » Bowl locking system reducing the risk of accidents
- » Additional air intakes with the same characteristics of the inlet air (line)

Within a battery of filters the activated carbon version is placed at the end because it requires a pre-filtering like the coalescing filter. Given the characteristic of this filter, it is recommended to replace the filter element at least every 6 months or 1000 working hours.

The operating principle is based on the adsorption characteristic of the filtering element which is composed of extremely porous fibers placed on different layers. These fibers create a cross-linked and are thus able to adsorb wet parts and contaminants remaining in the passing air, for example oil vapours/smokes, as well as odours generated from these contaminants.

GENERAL DATA

Construction	modular, compact with activated carbon filtering element
Materials	see TABLE OF MATERIALS on the following page
Ports	With interchangeable cartridges: 1/8, 1/4 and 3/8 threaded or integrated with super-rapid fitting for tube with \varnothing 6, 8 and 10 mm
Mounting	vertical in-line; wall-mounting by means of through holes in the body or with a support bracket
Operating temperature	10°C ÷ 40°C (t max = 60°C)
Condensate drain	not present
Quality of delivered air according to ISO 8573-1:2010	Class 1.7.1 (pre-filtering in Class 1.8.1 is recommended)
Operating pressure	0.3 ÷ 16 bar
Nominal flow	see FLOW DIAGRAMS on the following pages
Filtering element	activated carbon
Residual oil content	< 0.003 mg/m ³
Fluid	compressed air

CODING EXAMPLE

MD	1	-	FCA	0	-	1/8
-----------	----------	----------	------------	----------	----------	------------

MD	SERIES
1	DIMENSION: 1 = 42 mm
FCA	ACTIVATED CARBON FILTER
0	VISUAL BLOCKAGE INDICATOR: 0 = not present 1 = present
1/8	PORTS (IN - OUT)*: = without cartridges 1/8 = G1/8 1/4 = G1/4 3/8 = G3/8 6 = tube Ø6 8 = tube Ø8 10 = tube Ø10 * NOTE: if the inlet (IN) cartridge is different from the outlet (OUT) cartridge, both dimensions shall be indicated. Example: MD1-FCA1-1/4-10

SERIES MD ACTIVATED CARBON FILTERS

Series MD activated carbon filters - materials

A = filter
B = filter with visual blockage indicator

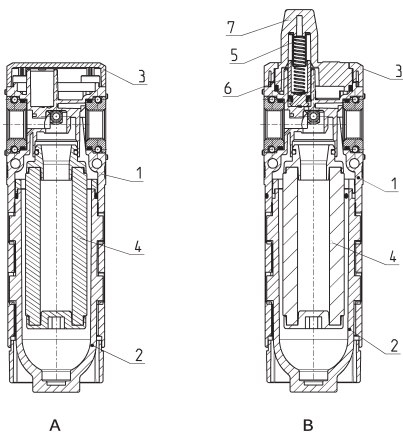

PARTS	MATERIALS
1 = Body	Polyamide
2 = Tank	Polycarbonate
3 = Covering	Polyamide
4 = Filtering element	Active carbons
5 = Upper spring	Stainless steel
6 = Piston	Anodized aluminium
7 = Visual blockage indicator	Polycarbonate
Seals	NBR

FLOW DIAGRAMS

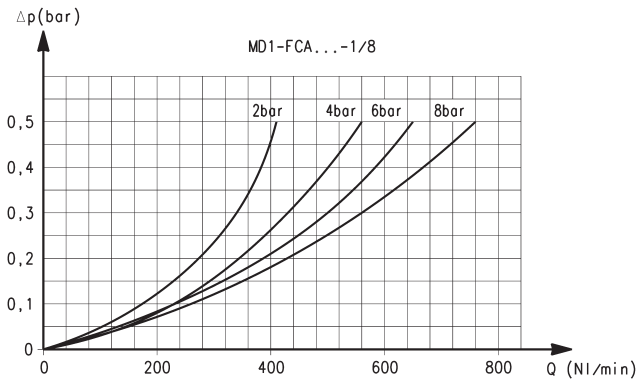

Ports with interchangeable 1/8 threaded cartridges

Δp = Pressure drop (bar)
Q = Flow (NL/min)

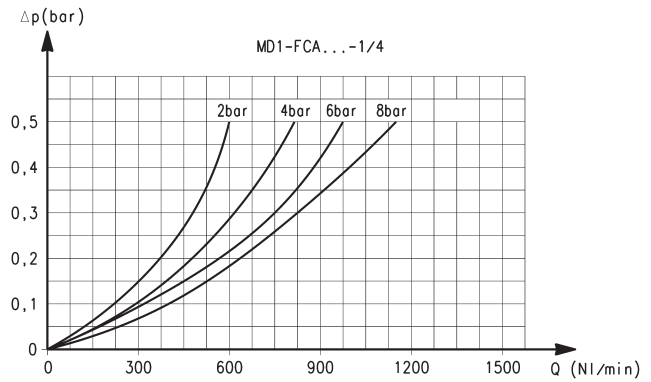

Ports with interchangeable 1/4 threaded cartridges

Δp = Pressure drop (bar)
Q = Flow (NL/min)

FLOW DIAGRAM

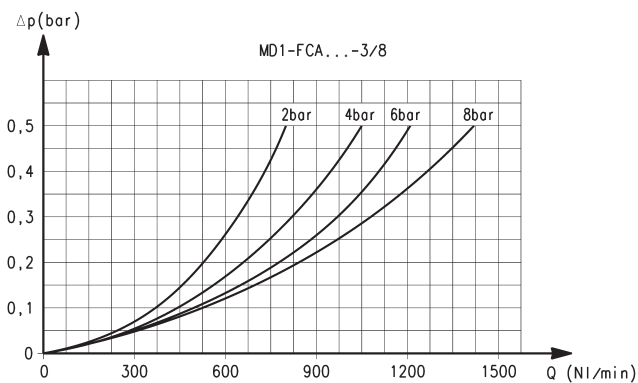

Ports with interchangeable 3/8 threaded cartridges

Δp = Pressure drop (bar)
Q = Flow (NL/min)

Series MD activated carbon filters - dimensions



FC01 = activated carbon filter

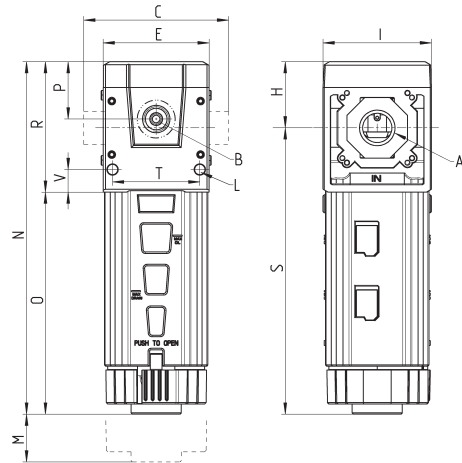
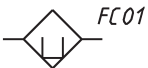

DIMENSIONS																
Mod.	A	B	C	E	H	I	L	M	N	O	P	R	S	T	V	Weight (Kg)
MD1-FCA0	-	G1/8	42	42	26.2	43	Ø4	90	139.7	88	22.7	51.7	113.5	34.6	9	0.2
MD1-FCA0-1/8	G1/8	G1/8	42	42	26.2	43	Ø4	90	139.7	88	22.7	51.7	113.5	34.6	9	0.2
MD1-FCA0-1/4	G1/4	G1/8	42	42	26.2	43	Ø4	90	139.7	88	22.7	51.7	113.5	34.6	9	0.2
MD1-FCA0-3/8	G3/8	G1/8	42	42	26.2	43	Ø4	90	139.7	88	22.7	51.7	113.5	34.6	9	0.2
MD1-FCA0-6	Ø6	G1/8	47	42	26.2	43	Ø4	90	139.7	88	22.7	51.7	113.5	34.6	9	0.2
MD1-FCA0-8	Ø8	G1/8	62	42	26.2	43	Ø4	90	139.7	88	22.7	51.7	113.5	34.6	9	0.2
MD1-FCA0-10	Ø10	G1/8	67	42	26.2	43	Ø4	90	139.7	88	22.7	51.7	113.5	34.6	9	0.2

Series MD activated carbon filters with visual indicator - dimensions



FC02 = activated carbon filter with visual blockage indicator

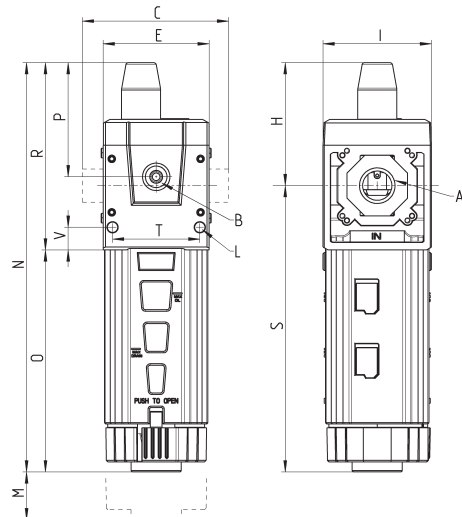
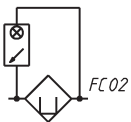

DIMENSIONS																
Mod.	A	B	C	E	H	I	L	M	N	O	P	R	S	T	V	Weight (Kg)
MD1-FCA1	-	G1/8	42	42	48.7	43	Ø4	90	162.2	88	45.2	74.2	113.5	34.6	9	0.2
MD1-FCA1-1/8	G1/8	G1/8	42	42	48.7	43	Ø4	90	162.2	88	45.2	74.2	113.5	34.6	9	0.2
MD1-FCA1-1/4	G1/4	G1/8	42	42	48.7	43	Ø4	90	162.2	88	45.2	74.2	113.5	34.6	9	0.2
MD1-FCA1-3/8	G3/8	G1/8	42	42	48.7	43	Ø4	90	162.2	88	45.2	74.2	113.5	34.6	9	0.2
MD1-FCA1-6	Ø6	G1/8	47	42	48.7	43	Ø4	90	162.2	88	45.2	74.2	113.5	34.6	9	0.2
MD1-FCA1-8	Ø8	G1/8	62	42	48.7	43	Ø4	90	162.2	88	45.2	74.2	113.5	34.6	9	0.2
MD1-FCA1-10	Ø10	G1/8	67	42	48.7	43	Ø4	90	162.2	88	45.2	74.2	113.5	34.6	9	0.2

Series MD pressure regulators

Ports with interchangeable cartridges: threaded (1/8, 1/4, 3/8) or integrated with super-rapid fitting for tube with Ø 6, 8 and 10 mm
Versions: single, combined with other functions, Manifold



- » Minimal pressure decreases
- » Knob with position lock
- » Tamper-proof system (lockable regulator)
- » With or without overpressure exhaust (relieving)
- » Available versions: Manifold, with by-pass valve, calibrated, locked.

Thanks to the flexibility given by the connection inserts, the regulator can be adjusted within a treatment group so that the regulation knob is in the front or lower position. Once the regulation is locked, it is possible to insert as many security locks through the 4 holes.

The by-pass valve allows the fast exhaust of the air introduced.

The different springs enable a more accurate adjustment of the pressure.

The Series MD offers multi-sector solutions that ensure saving in terms of installation time, space and costs. Thanks to the solution adopted for the pneumatic connection, it is possible to equip the same element with interchangeable cartridges that can either be threaded, or with an integrated super-rapid fitting, both types available in different sizes. Intermediate cartridges can be also integrated to join multiple functions or with derivation to draw air.

GENERAL DATA

Construction	modular, compact with pre-formed diaphragm
Materials	see TABLE OF MATERIALS on the following page
Ports	with interchangeable cartridges: 1/8, 1/4 and 3/8 threaded or integrated with super-rapid fitting for tube with Ø 6, 8 and 10 mm
Fixing	in-line; wall-mounting by means of through holes in the body or with a support bracket; panel mounting
Operating temperature	-5°C ÷ 50°C up to 16 bar
Inlet pressure	0 ÷ 16 bar
Outlet pressure	0.5 ÷ 2 bar 0.5 ÷ 4 bar 0.5 ÷ 7 bar 0.5 ÷ 10 bar
Overpressure exhaust	with relieving without relieving
Nominal flow	see FLOW DIAGRAMS on the following pages
Fluid	compressed air

CODING EXAMPLE

MD	1	-	R	T	0	0	-	1/4	-	■	-	●
-----------	----------	----------	----------	----------	----------	----------	----------	------------	----------	----------	----------	----------

MD	SERIES
1	SIZE: 1 = 42 mm
R	TYPE OF REGULATOR: R = pressure regulator M = Manifold pressure regulator
T	OPERATING PRESSURE (1 bar = 14,5 psi): 0 = 0.5 ÷ 10 bar 2 = 0.5 ÷ 2 bar 4 = 0.5 ÷ 4 bar 7 = 0.5 ÷ 7 bar T = calibrated ** B = locked **
0	DESIGN TYPE: 0 = with relieving 1 = without relieving 2 = with relieving and by-pass valve (only for R regulator) 3 = without relieving, with by-pass valve (only for R regulator)
0	PRESSURE GAUGE: 0 = without pressure gauge (with 1/8 port)
1/4	PORTS (IN - OUT)*: = without cartridges 1/8 = G1/8 1/4 = G1/4 3/8 = G3/8 6 = tube Ø6 8 = tube Ø8 10 = tube Ø10 * NOTE: if the inlet (IN) cartridge is different from the outlet (OUT) cartridge, both dimensions shall be indicated. Example: MD1-R020-1/4-10
<p>** NOTE: IF THE REGULATOR IS CALIBRATED OR LOCKED, AFTER THE PORTS ADD THE INLET PRESSURE "■" AND THE OUTLET PRESSURE "●"</p> <p>INLET PRESSURE: ■ = enter the SUPPLY pressure value</p> <p>OUTLET PRESSURE: ● = enter the OUTLET pressure value for the LOCKED regulator or the maximum value of the ADJUSTABLE pressure for the CALIBRATED regulator</p> <p>Example of a calibrated regulator with Inlet Pressure = 6.3 bar and Outlet Pressure = 4.5 bar Complete part number: MD1-RT00-1/4-6.3-4.5</p>	

SERIES MD REGULATORS

Pressure regulators Series MD - materials

R = pressure regulator
M = Manifold pressure regulator

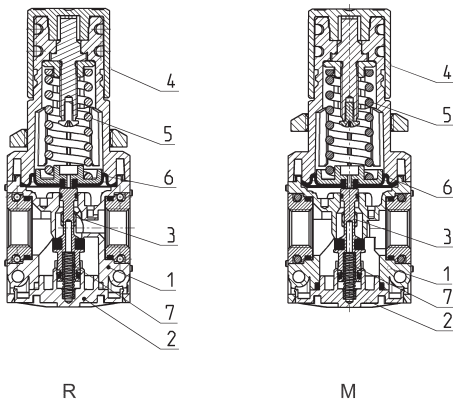

PARTS	MATERIALS
1 = Body	Polyamide
2 = Valve holder plug	Polyamide
3 = Poppet	Brass
4 = Knob	Polyamide
5 = Upper spring	Zinc-plated steel
6 = Diaphragm	NBR
7 = Lower spring	Stainless steel
Seals	NBR

FLOW DIAGRAMS for regulators with working pressures of 2, 4, 7, 10 bar

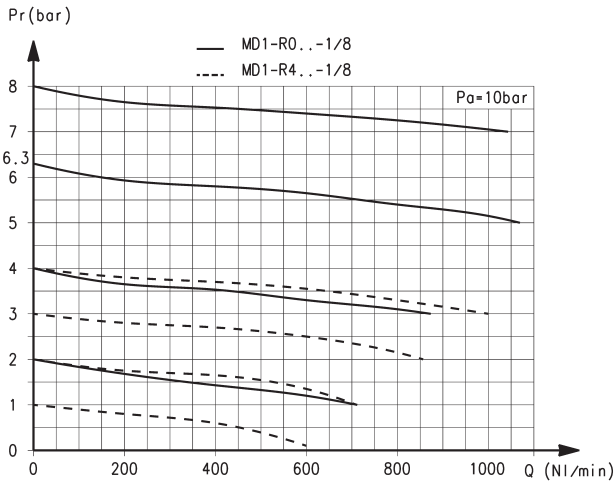

Ports with interchangeable 1/8 threaded cartridges

Pr = Regulated pressure (bar)
Q = Flow (NI/min)

Pa = Inlet pressure (bar)

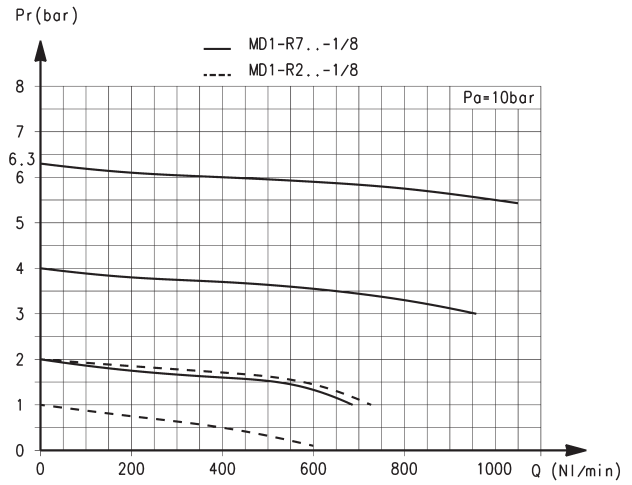

Ports with interchangeable 1/8 threaded cartridges

Pr = Regulated pressure (bar)
Q = Flow (NI/min)

Pa = Inlet pressure (bar)

FLOW DIAGRAMS for regulators with working pressures of 2, 4, 7, 10 bar

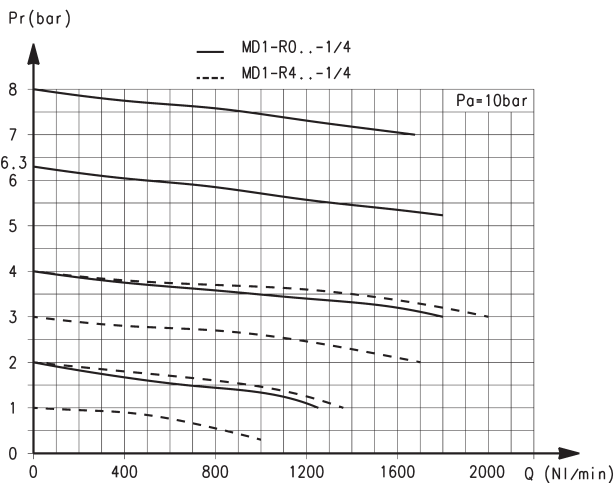

Ports with interchangeable 1/4 threaded cartridges

Pr = Regulated pressure
Q = Flow

Pa = Inlet pressure

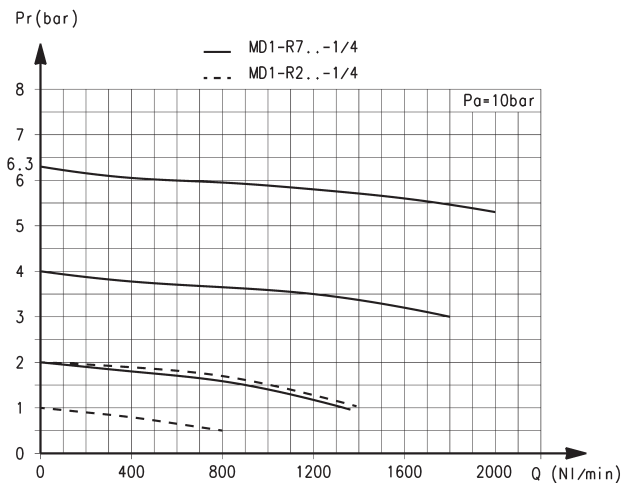

Ports with interchangeable 1/4 threaded cartridges

Pr = Regulated pressure
Q = Flow

Pa = Inlet pressure

FLOW DIAGRAMS for regulators with working pressures of 2, 4, 7, 10 bar

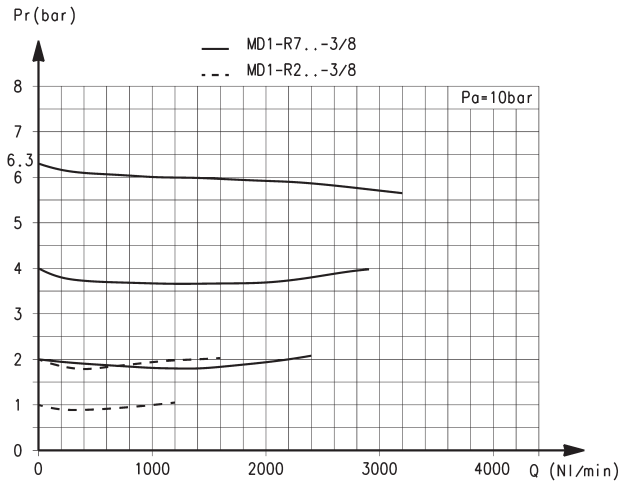
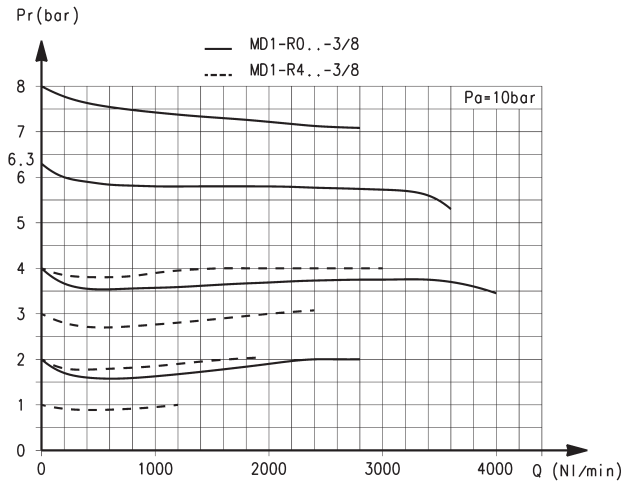

Ports with interchangeable 3/8 threaded cartridges

Pr = Regulated pressure (bar)
Q = Flow (NI/min)

Pa = Inlet pressure (bar)

Ports with interchangeable 3/8 threaded cartridges

Pr = Regulated pressure (bar)
Q = Flow (NI/min)

Pa = Inlet pressure (bar)

Series MD pressure regulators - dimensions



- PR01 = regulator without relieving
- PR02 = regulator with relieving
- PR03 = regulator with relieving and by-pass valve
- PR04 = regulator without relieving and with by-pass valve

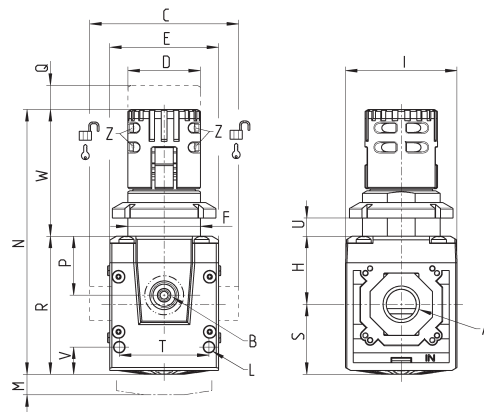
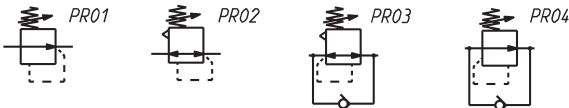

Mod.	A	B	C	D	E	F	H	I	L	M	N	P	Q	R	S	T	U	V	W	Z	Weight (Kg)
MD1-R000	-	G1/8	42	Ø28	42	M28X1,5	26.2	43	Ø4	16	102	22.7	4	53.2	27	34.6	0 ÷ 11	10.5	48.8	Ø3.2	0.2
MD1-R000-1/8	G1/8	G1/8	42	Ø28	42	M28X1,5	26.2	43	Ø4	16	102	22.7	4	53.2	27	34.6	0 ÷ 11	10.5	48.8	Ø3.2	0.2
MD1-R000-1/4	G1/4	G1/8	42	Ø28	42	M28X1,5	26.2	43	Ø4	16	102	22.7	4	53.2	27	34.6	0 ÷ 11	10.5	48.8	Ø3.2	0.2
MD1-R000-3/8	G3/8	G1/8	42	Ø28	42	M28X1,5	26.2	43	Ø4	16	102	22.7	4	53.2	27	34.6	0 ÷ 11	10.5	48.8	Ø3.2	0.2
MD1-R000-6	Ø6	G1/8	47	Ø28	42	M28X1,5	26.2	43	Ø4	16	102	22.7	4	53.2	27	34.6	0 ÷ 11	10.5	48.8	Ø3.2	0.2
MD1-R000-8	Ø8	G1/8	62	Ø28	42	M28X1,5	26.2	43	Ø4	16	102	22.7	4	53.2	27	34.6	0 ÷ 11	10.5	48.8	Ø3.2	0.2
MD1-R000-10	Ø10	G1/8	67	Ø28	42	M28X1,5	26.2	43	Ø4	16	102	22.7	4	53.2	27	34.6	0 ÷ 11	10.5	48.8	Ø3.2	0.2

FLOW DIAGRAMS for Manifold regulators with working pressures of 2, 4, 7, 10 bar

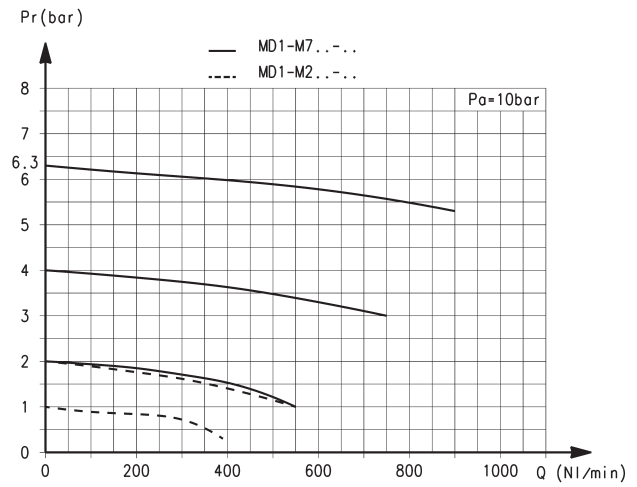
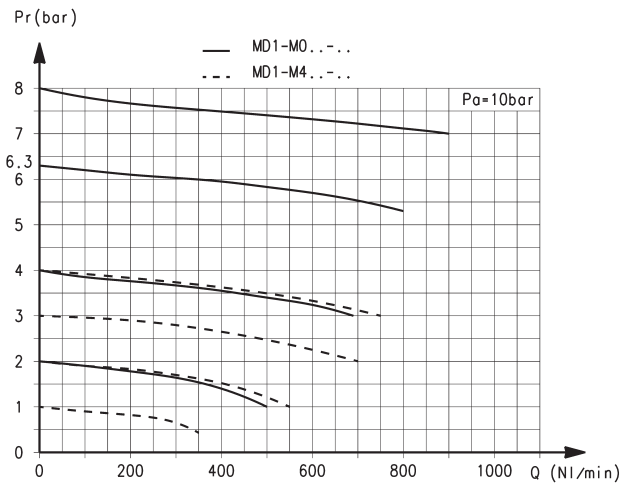

Pr = Regulated pressure (bar)
Q = Flow (NI/min)

Pa = Inlet pressure (bar)

Pr = Regulated pressure (bar)
Q = Flow (NI/min)

Pa = Inlet pressure (bar)

MANIFOLD REGULATOR - PNEUMATIC SYMBOLS

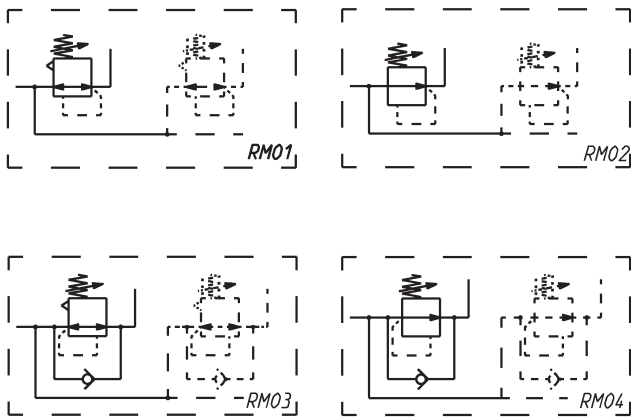

RM01 = Manifold regulator with relieving
 RM02 = Manifold regulator without relieving
 RM03 = Manifold regulator with relieving and by-pass valve
 RM04 = Manifold regulator without relieving, with by-pass valve

Series MD pressure regulators - dimensions



With the Manifold version it is possible to realize a battery of regulators which are fed by a single source of inlet pressure. Each regulator can be set up at any pressure (lower than the inlet pressure). The front or rear connection of each regulator allows to draw air at the pressure value set on the regulator itself.

There is no limit to the number of regulators that can be connected.

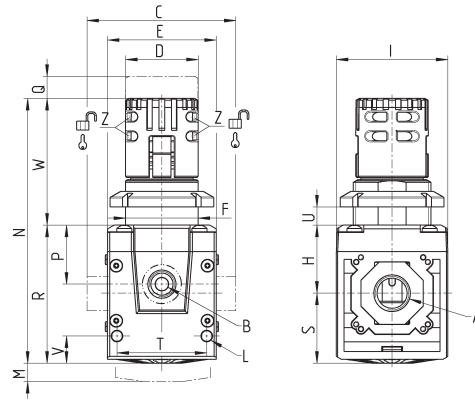

SERIES MD REGULATORS

Mod.	A	B	C	D	E	F	H	I	L	M	N	P	Q	R	S	T	U	V	W	Z	Weight (Kg)
MD1-M000	-	G1/8	42	Ø28	42	M28X1,5	26.2	43	Ø4	16	102	22.7	4	53.2	27	34.6	0 ÷ 11	10.5	48.8	Ø3.2	0.2

Series MD lubricators

Ports with interchangeable cartridges: threaded (1/8, 1/4, 3/8) or integrated with super-rapid fitting for tube with \varnothing 6, 8 and 10 mm

Modular assembly

Bowl with technopolymer cover and bayonet-type mounting



- » Regulation screw
- » Ability to refill the oil even with system under pressure
- » High flow
- » Check of the oil level through plastic cover openings
- » Bowl locking system reducing the risk of accidents
- » Additional air intakes with the same characteristics of the outlet air (line)

The lubricator allows the nebulization of lubricating oil which is necessary to the functioning of components in specific conditions of use.

By means of a regulation screw the amount of oil can be properly adjusted in order to avoid unnecessary overdoses.

GENERAL DATA

Construction	modular, compact
Materials	see TABLE OF MATERIALS on the following page
Ports	with interchangeable cartridges: 1/8, 1/4 and 3/8 threaded or integrated with super-rapid fitting for tube with \varnothing 6, 8 and 10 mm
Oil capacity	40 cm ³
Oil refilling	even during use
Mounting	in vertical position by means of through holes in the body
Operating temperature	-5°C ÷ 50°C up to 16 bar
Oil for lubrication	use ISO VG32 oils. Once applied, the lubrication should never be interrupted.
Operating pressure	0 ÷ 16 bar
Min. air consumption for lubrication at 1 bar	15 NI/min
Min. air consumption for lubrication at 6 bar	25 NI/min
Nominal flow	see FLOW DIAGRAMS on the following pages
fluid	compressed air

CODING EXAMPLE

MD	1	-	L	0	0	-	1/8
-----------	----------	----------	----------	----------	----------	----------	------------

MD	SERIES
1	DIMENSION: 1 = 42 mm
L	LUBRICATOR
00	DESIGN TYPE: 00 = oil mist with refill valve 10 = oil mist without refill valve
1/8	PORTS (IN - OUT)*: = without ports 1/8 = G1/8 1/4 = G1/4 3/8 = G3/8 6 = tube Ø6 8 = tube Ø8 10 = tube Ø10 * NOTE: if the inlet (IN) cartridge is different from the outlet (OUT) cartridge, both dimensions shall be indicated. Example: MD1-L00-1/4-1/8

SERIES MD LUBRICATORS

Series MD lubricators - materials

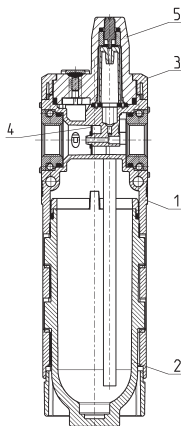

PARTS	MATERIALS
1 = Body	Polyamide
2 = Tank	Polycarbonate
3 = Covering	Polyamide
4 = Diaphragm	NBR
5 = Visual blockage indicator	Polycarbonate
Seals	NBR

FLOW DIAGRAMS

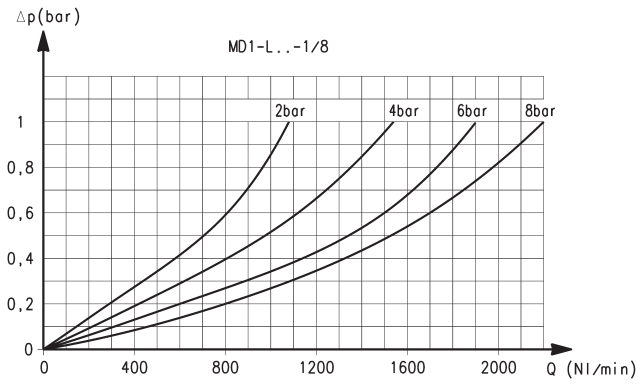

Ports with interchangeable 1/8 threaded cartridges

Δp = Pressure drop (bar)
Q = Flow (NL/min)

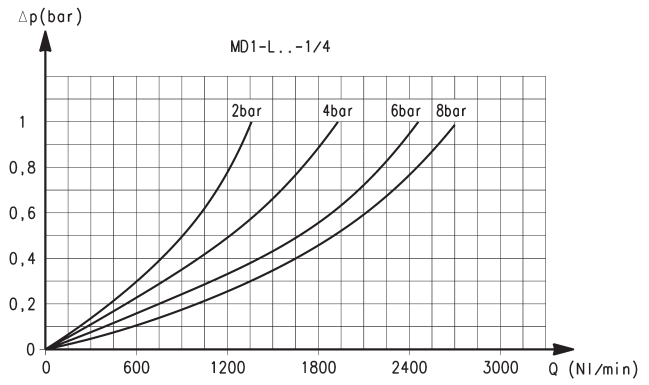

Ports with interchangeable 1/4 threaded cartridges

Δp = Pressure drop (bar)
Q = Flow (NL/min)

FLOW DIAGRAM

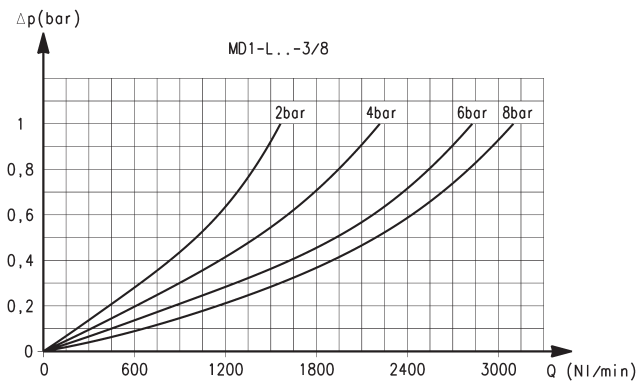

Ports with interchangeable 3/8 threaded cartridges

Δp = Pressure drop (bar)
Q = Flow (NL/min)

Series MD lubricators - dimensions



LU0 = Lubricator

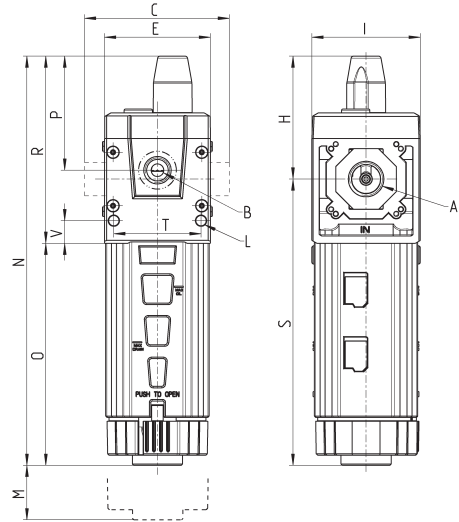
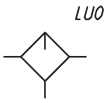

DIMENSIONS																
Mod.	A	B	C	E	H	I	L	M	N	O	P	R	S	T	V	Weight (Kg)
MD1-L00	-	G1/8	42	42	48.7	43	Ø4	75	162.2	88	45.2	74.2	113.5	34.6	9	0.2
MD1-L00-1/8	G1/8	G1/8	42	42	48.7	43	Ø4	75	162.2	88	45.2	74.2	113.5	34.6	9	0.2
MD1-L00-1/4	G1/4	G1/8	42	42	48.7	43	Ø4	75	162.2	88	45.2	74.2	113.5	34.6	9	0.2
MD1-L00-3/8	G3/8	G1/8	42	42	48.7	43	Ø4	75	162.2	88	45.2	74.2	113.5	34.6	9	0.2
MD1-L00-6	Ø6	G1/8	47	42	48.7	43	Ø4	75	162.2	88	45.2	74.2	113.5	34.6	9	0.2
MD1-L00-8	Ø8	G1/8	62	42	48.7	43	Ø4	75	162.2	88	45.2	74.2	113.5	34.6	9	0.2
MD1-L00-10	Ø10	G1/8	67	42	48.7	43	Ø4	75	162.2	88	45.2	74.2	113.5	34.6	9	0.2

Series MD pressure filter-regulators

Ports with interchangeable cartridges: threaded (1/8, 1/4, 3/8) or integrated with super-rapid fitting for tube with \varnothing 6, 8 and 10 mm

Modular assembly

Bowl with technopolymer cover and bayonet-type mounting



- » Filtering between 25 μm or 5 μm
- » Minimum pressure drops
- » Knob with position lock
- » Tamper-proof system (lockable regulator)
- » Bowl locking system reducing the risk of accidents

Series MD filter-regulators integrate filter and pressure reducer in one unit, thus reducing their dimensions.

The by-pass valve allows the fast exhaust of the air introduced. The different springs enable a more accurate adjustment of the pressure.

Thanks to the solution adopted for the pneumatic connection, it is possible to equip the same element with interchangeable cartridges that can either be threaded, or with an integrated super-rapid fitting, both types available in different sizes. Intermediate cartridges can be also integrated to join multiple functions or with derivation to draw air.

GENERAL DATA

Construction	modular, compact with filtering element in HDPE
Materials	see TABLE OF MATERIALS on the following page
Ports	with interchangeable cartridges: 1/8, 1/4 and 3/8 threaded or integrated with super-rapid fitting for tube with diameters of 6, 8 and 10 mm
Condensate capacity	24 cm ³
Mounting	in-line; wall-mounting by means of through holes in the body or with a support bracket; panel mounting
Operating temperature	-5°C ÷ 50°C up to 16 bar (with the dew point of the fluid lower than 2°C at the min. working temperature)
Condensate drain	semi-automatic manual, automatic, protected depressurisation, direct G1/8 exhaust
Quality of delivered air according to ISO 8573-1 2010	Class 6.8.4 with 5 μm filtering element Class 7.8.4 with 25 μm filtering element
Inlet pressure	0.3 ÷ 16 bar (with automatic drain 1 ÷ 9 bar)
Exit pressure	0.5 ÷ 2bar 0.5 ÷ 4bar 0.5 ÷ 7bar 0.5 ÷ 10bar
Nominal flow	see FLOW DIAGRAMS on the following pages
Fluid	compressed air

CODING EXAMPLE

MD	1	-	FR	0	0	0	0	-	1/8
-----------	----------	----------	-----------	----------	----------	----------	----------	----------	------------

MD	SERIES
1	DIMENSION: 1 = 42 mm
FR	FILTER-REGULATOR
0	FILTERING ELEMENT (further details in the dedicated section) AND DESIGN TYPE: 0 = 25 µm with relieving 1 = 5 µm with relieving 2 = 25 µm without relieving * 3 = 5 µm without relieving * 4 = 25 µm with relieving and by-pass valve 5 = 5 µm with relieving and by-pass valve 6 = 25 µm without relieving, with by-pass valve * 7 = 5 µm without relieving, with by-pass valve * * this option is available with semiautomatic-manual drain only
0	DRAINING OF CONDENSATE (further details in the dedicated section): 0 = semiautomatic-manual drain 3 = automatic drain 5 = protected depressurisation 8 = direct G1/8 exhaust
0	OPERATING PRESSURE (1 bar = 14,5 psi): 0 = 0.5 ÷ 10 bar 2 = 0.5 ÷ 2 bar 4 = 0.5 ÷ 4 bar 7 = 0.5 ÷ 7 bar
0	PRESSURE GAUGE: 0 = without pressure gauge (with 1/8 port)
1/8	PORTS (IN - OUT)*: = without cartridges 1/8 = G1/8 1/4 = G1/4 3/8 = G3/8 6 = tube Ø6 8 = tube Ø8 10 = tube Ø10 * NOTE: if the inlet (IN) cartridge is different from the outlet (OUT) cartridge, both dimensions shall be indicated. Example: MD1-FR0000-1/4-1/8

SERIES MD FILTER-REGULATORS

Series MD filter-regulators - materials

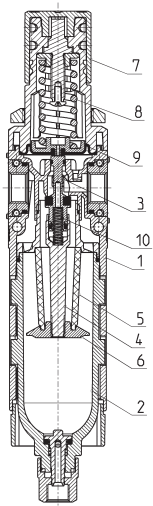

PARTS	MATERIALS
1 = Body	Polyamide
2 = Tank	Polycarbonate
3 = Poppet	Brass
4 = Valve guide	Polyacetal
5 = Filtering element	Polyethylene
6 = Separation deflector	Polyacetal
7 = Knob	Polyamide
8 = Upper spring	Zinc-plated steel
9 = Diaphragm	NBR
10 = Lower spring	Stainless steel
Seals	NBR

FLOW DIAGRAMS

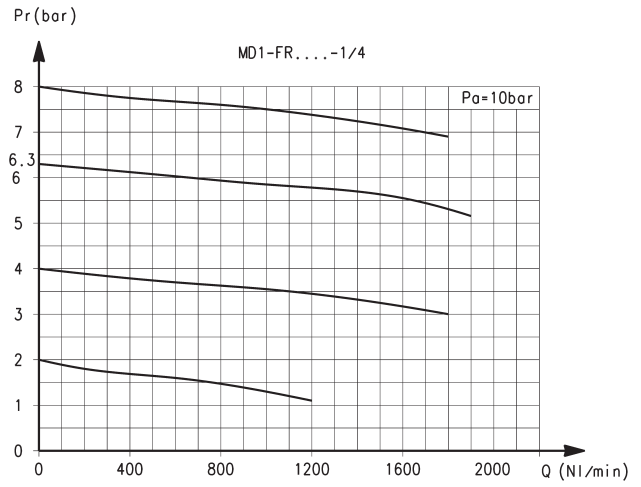
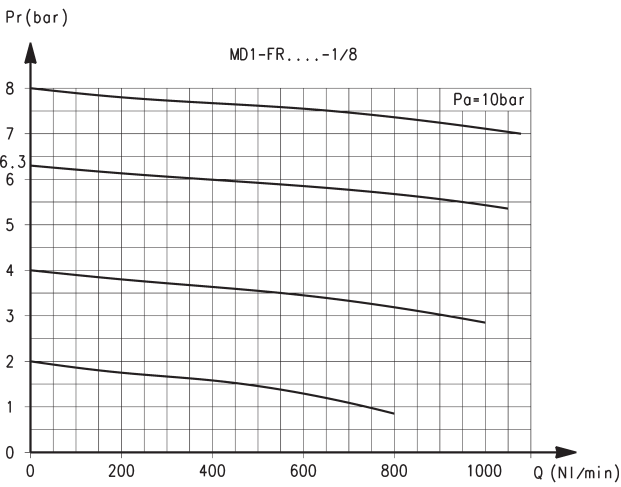

Ports with interchangeable G1/8 threaded cartridges

Pr = Regulated pressure (bar)
Q = Flow (NL/min)

Pa = Inlet pressure (bar)

Ports with interchangeable G1/4 threaded cartridges

Pr = Regulated pressure (bar)
Q = Flow (NL/min)

Pa = Inlet pressure (bar)

FLOW DIAGRAM

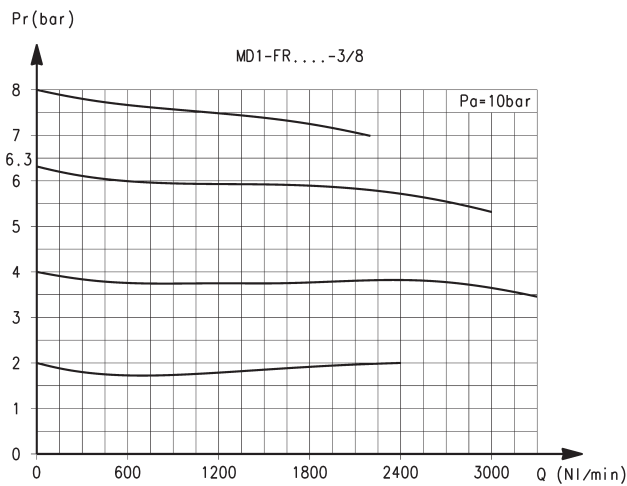

Ports with interchangeable G3/8 threaded cartridges

Pr = Regulated pressure (bar)
Q = Flow (NL/min)

Pa = Inlet pressure (bar)

N.B: The version with automatic exhaust has a flow reduction of max 10%

PNEUMATIC SYMBOLS

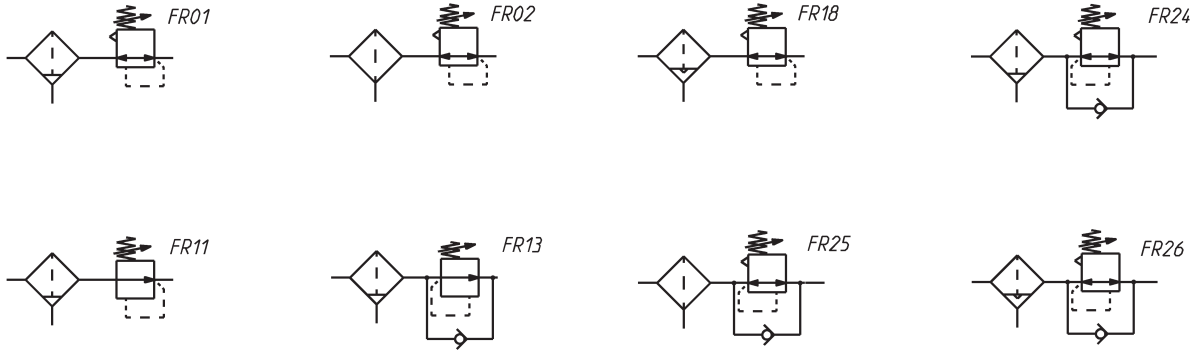

FR01 = filter-regulator with relieving and semi-automatic manual drain
 FR02 = filter-regulator with relieving and direct G1/8 exhaust
 FR11 = filter-regulator without relieving, with semi-automatic manual drain
 FR13 = filter-regulator without relieving, with by-pass valve and semi-automatic manual drain

FR18 = filter-regulator with relieving and automatic/depressuring drain
 FR24 = filter-regulator with relieving, by-pass valve and semi-automatic manual drain
 FR25 = filter-regulator with relieving, by-pass valve and direct G1/8 exhaust
 FR26 = filter-regulator with relieving, by-pass valve and automatic/depressuring drain

SERIES MD FILTER-REGULATORS

Series MD filter-regulators - dimensions

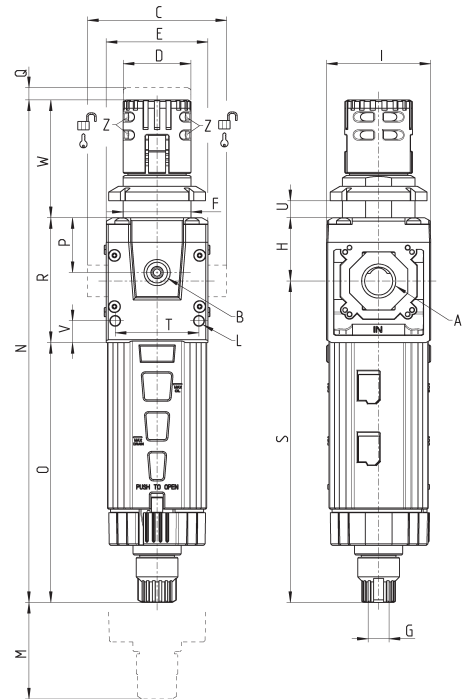

Mod.	A	B	C	D	E	F	G	H	I	L	M	N	O	P	Q	R	S	T	U	V	W	Z	Weight (Kg)
MD1-FR0000	-	G1/8	42	Ø28	42	M28X1,5	G1/8	26.2	43	Ø4	110	208.2	107.7	22.7	4	51.7	133.2	34.6	0 ± 11	9	48.8	Ø3.2	0.2
MD1-FR0000-1/8	G1/8	G1/8	42	Ø28	42	M28X1,5	G1/8	26.2	43	Ø4	110	208.2	107.7	22.7	4	51.7	133.2	34.6	0 ± 11	9	48.8	Ø3.2	0.2
MD1-FR0000-1/4	G1/4	G1/8	42	Ø28	42	M28X1,5	G1/8	26.2	43	Ø4	110	208.2	107.7	22.7	4	51.7	133.2	34.6	0 ± 11	9	48.8	Ø3.2	0.2
MD1-FR0000-3/8	G3/8	G1/8	42	Ø28	42	M28X1,5	G1/8	26.2	43	Ø4	110	208.2	107.7	22.7	4	51.7	133.2	34.6	0 ± 11	9	48.8	Ø3.2	0.2
MD1-FR0000-6	Ø6	G1/8	47	Ø28	42	M28X1,5	G1/8	26.2	43	Ø4	110	208.2	107.7	22.7	4	51.7	133.2	34.6	0 ± 11	9	48.8	Ø3.2	0.2
MD1-FR0000-8	Ø8	G1/8	62	Ø28	42	M28X1,5	G1/8	26.2	43	Ø4	110	208.2	107.7	22.7	4	51.7	133.2	34.6	0 ± 11	9	48.8	Ø3.2	0.2
MD1-FR0000-10	Ø10	G1/8	67	Ø28	42	M28X1,5	G1/8	26.2	43	Ø4	110	208.2	107.7	22.7	4	51.7	133.2	34.6	0 ± 11	9	48.8	Ø3.2	0.2
MD1-FR0300	-	G1/8	42	Ø28	42	M28X1,5	M10x1	26.2	43	Ø4	110	197.6	97.4	22.7	4	51.7	122.9	34.6	0 ± 11	9	48.8	Ø3.2	0.2

Series MD lockable isolation 3/2-way valves

Ports with interchangeable cartridges: threaded (1/8, 1/4, 3/8) or integrated with super-rapid fitting for tube with \varnothing 6, 8 and 10 mm

Modular

Manual, electro-pneumatic, servo-pilot and pneumatic control



- » Standard tamperproof lock-out (manual valve)
- » 24 V, 110 V or 230 V coils
- » Solenoid valve with or without manual override available in different types
- » Additional air intakes with the same characteristics of the inlet air (line)

The Series MD offers multi-sector solutions that ensure saving in terms of installation time, space and costs.

Series MD lockable isolation valves allow the inlet and exhaust of compressed air from the plant and can meet several application requirements.

The electric version can be equipped with different options of manual override (Push & Turn, Push-in, retaining lever). Moreover, a version without override is also available.

The manually operated valve can be locked thanks to the use of padlocks.

GENERAL DATA

Construction	modular, compact, spool-type
Materials	see TABLE OF MATERIALS on the following page
Ports	with interchangeable cartridges: 1/8, 1/4 and 3/8 threaded, integrated with super-rapid fitting for tube with \varnothing 6, 8 and 10 mm
Fixing	in-line; wall-mounting by means of through holes in the body or with a support bracket; panel-mounting (for manually operated version only)
Operating temperature	-5°C ÷ 50°C up to 16 bar
Operating pressure	Manual valve: -0.8 bar ÷ 10 bar Electro-pneumatic valve: 2 bar ÷ 10 bar Servopilot or pneumatic valve: -0.8 bar ÷ 10 bar (with pilot 2 ÷ 10 bar)
Nominal flow	see FLOW DIAGRAMS on the following pages
Nominal exhaust flow at 6 bar with $\Delta p = 1$ bar	850 NL/min
Fluid	compressed air

CODING EXAMPLE

MD	1	-	V	01	-	1/8
-----------	----------	----------	----------	-----------	----------	------------

MD	SERIES	
1	DIMENSION: 1 = 42 mm	
V	3/2-WAY VALVE	
01	DESIGN TYPE: 01 = lockable manual control 16 = electro-pneumatic control, Push & Turn manual override 16IL = electro-pneumatic control, bistable manual override, lever type	16IM = electro-pneumatic control, monostable manual override 16IT = electro-pneumatic control without manual override 36 = pneumatic control
1/8	PORTS (IN - OUT) *: = without cartridges 1/8 = G1/8 1/4 = G1/4 3/8 = G3/8 6 = tube Ø6 8 = tube Ø8 10 = tube Ø10	

* NOTE: if the inlet (IN) cartridge is different from the outlet (OUT) cartridge, both dimensions shall be indicated.
Example: MD1-V01-1/4-1/8

TYPES OF MANUAL OVERRIDE

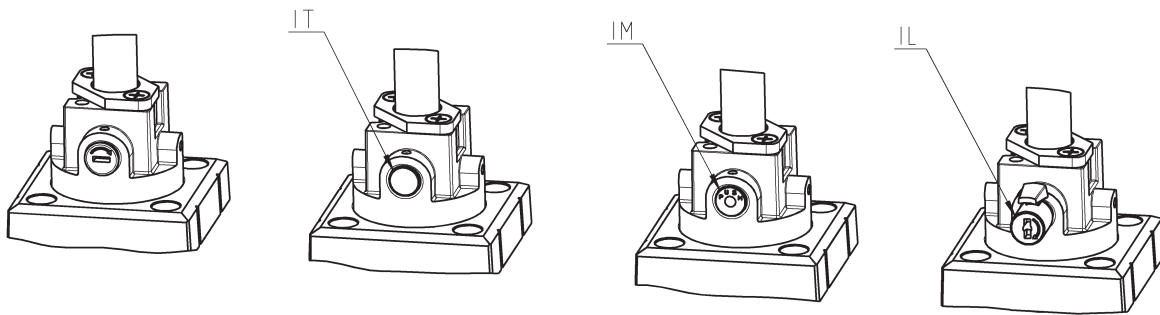

Push & Turn manual override

IT = without manual override
IL = bistable manual override, lever type
IM = monostable manual override

Series MD lockable isolation 3/2-way valves - materials

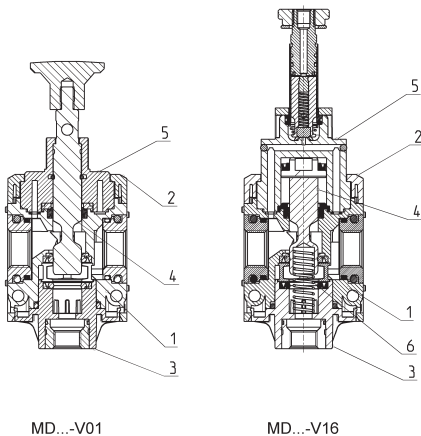

PARTS	MATERIALS
1 = Body	Polyamide
2 = Covering	Polyamide
3 = Plug	Polyamide
4 = Spool	Anodized aluminium
5 = End-cover	Polyamide
6 = Lower spring	Stainless steel
Seals	NBR

FLOW DIAGRAMS for manually operated models

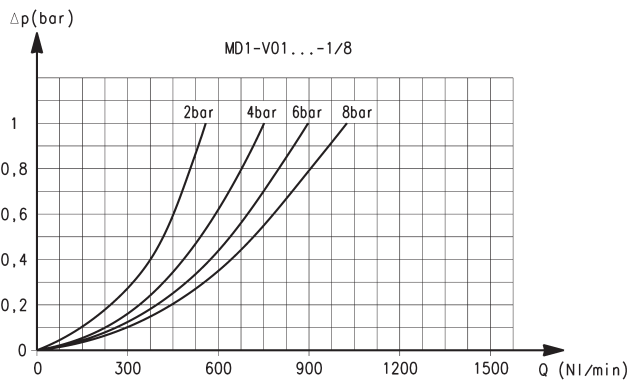

Ports with interchangeable G1/8 threaded cartridges

Δp = Pressure drop (bar)
Q = Flow (NL/min)

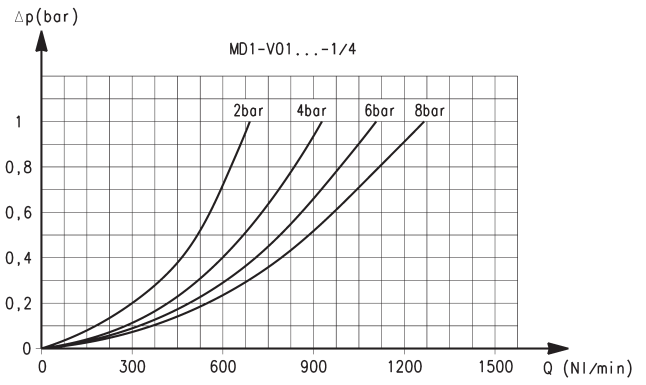

Ports with interchangeable G1/4 threaded cartridges

Δp = Pressure drop (bar)
Q = Flow (NL/min)

FLOW DIAGRAM for manually operated models

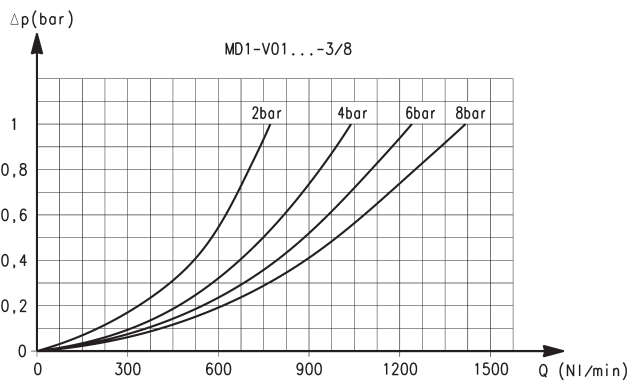

Ports with interchangeable G3/8 threaded cartridges

Δp = Pressure drop (bar)
Q = Flow (NL/min)

FLOW DIAGRAMS for electro-pneumatically or pneumatically operated models

SERIES MD 3/2-WAY ISOLATION VALVES

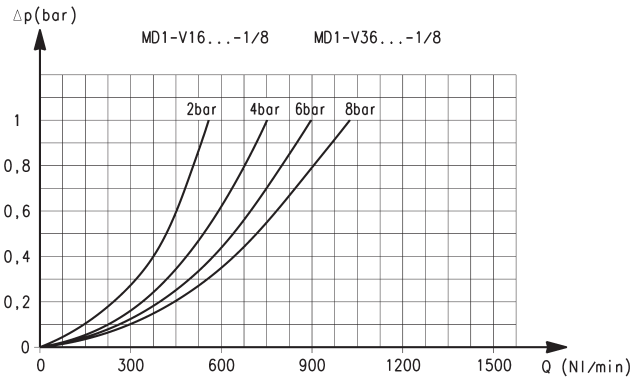

Ports with interchangeable G1/8 threaded cartridges

Δp = Pressure drop (bar)
 Q = Flow (NL/min)

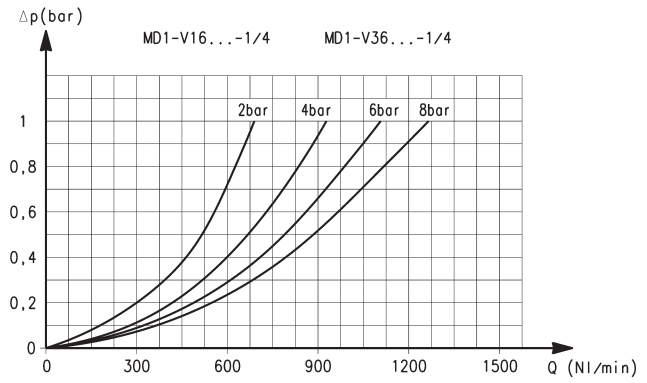

Ports with interchangeable G1/4 threaded cartridges

Δp = Pressure drop (bar)
 Q = Flow (NL/min)

FLOW DIAGRAM for electro-pneumatically or pneumatically operated models

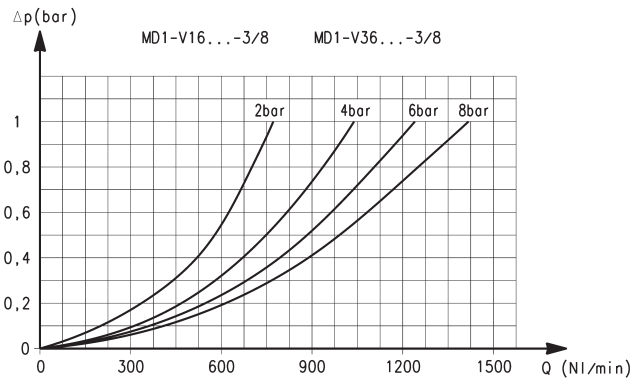

Ports with interchangeable G3/8 threaded cartridges

Δp = Pressure drop (bar)
 Q = Flow (NL/min)

Manually operated valves - dimensions

Fig. 1 = closed valve
Fig. 2 = open valve



VN27 = Lockable bistable manual valve 3/2

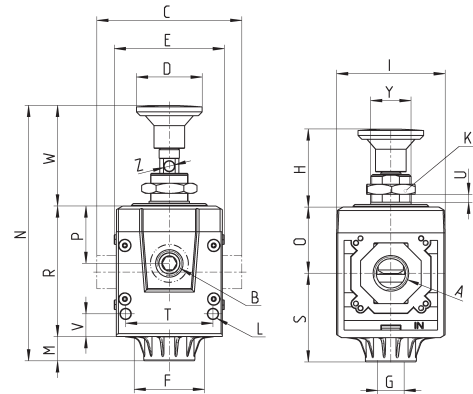
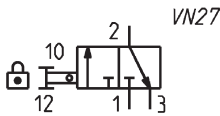

Fig.1

Fig.2

Mod.	A	B	C	D	E	F	G	H	I	K	L	M	N	O	P	R	S	T	U	V	W	Y	Z	Weight (Kg)
MD1-V01	-	G1/8	42	Ø26	42	28.5	G1/8	31	43	19	Ø4	9.5	101	26.2	22.7	51.7	35.1	34.6	0-8	9	39.8	M16X1	Ø4.5	0.2
MD1-V01-1/8	G1/8	G1/8	42	Ø26	42	28.5	G1/8	31	43	19	Ø4	9.5	101	26.2	22.7	51.7	35.1	34.6	0-8	9	39.8	M16X1	Ø4.5	0.2
MD1-V01-1/4	G1/4	G1/8	42	Ø26	42	28.5	G1/8	31	43	19	Ø4	9.5	101	26.2	22.7	51.7	35.1	34.6	0-8	9	39.8	M16X1	Ø4.5	0.2
MD1-V01-3/8	G3/8	G1/8	42	Ø26	42	28.5	G1/8	31	43	19	Ø4	9.5	101	26.2	22.7	51.7	35.1	34.6	0-8	9	39.8	M16X1	Ø4.5	0.2
MD1-V01-6	Ø6	G1/8	47	Ø26	42	28.5	G1/8	31	43	19	Ø4	9.5	101	26.2	22.7	51.7	35.1	34.6	0-8	9	39.8	M16X1	Ø4.5	0.2
MD1-V01-8	Ø8	G1/8	62	Ø26	42	28.5	G1/8	31	43	19	Ø4	9.5	101	26.2	22.7	51.7	35.1	34.6	0-8	9	39.8	M16X1	Ø4.5	0.2
MD1-V01-10	Ø10	G1/8	67	Ø26	42	28.5	G1/8	31	43	19	Ø4	9.5	101	26.2	22.7	51.7	35.1	34.6	0-8	9	39.8	M16X1	Ø4.5	0.2

Electro-pneumatically operated valves - dimensions



- * = add:
- IL for the version with bistable manual override, lever type (EV10)
 - IM for the version with monostable manual override (EV54)
 - IT for the version without manual override (EV55)

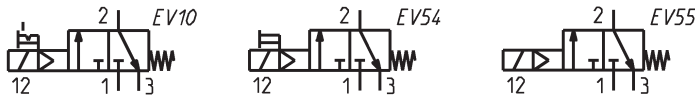
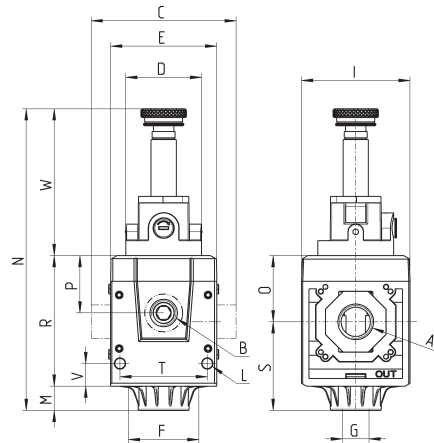

Mod.	A	B	C	D	E	F	G	I	L	M	N	O	P	R	S	T	V	W	Weight (Kg)
MD1-V16*	-	G1/8	42	Ø30	42	28.5	G1/8	43	Ø4	9.5	119.4	26.2	22.7	51.7	35.1	34.6	9	58.2	0.2
MD1-V16*-1/8	G1/8	G1/8	42	Ø30	42	28.5	G1/8	43	Ø4	9.5	119.4	26.2	22.7	51.7	35.1	34.6	9	58.2	0.2
MD1-V16*-1/4	G1/4	G1/8	42	Ø30	42	28.5	G1/8	43	Ø4	9.5	119.4	26.2	22.7	51.7	35.1	34.6	9	58.2	0.2
MD1-V16*-3/8	G3/8	G1/8	42	Ø30	42	28.5	G1/8	43	Ø4	9.5	119.4	26.2	22.7	51.7	35.1	34.6	9	58.2	0.2
MD1-V16*-6	Ø6	G1/8	47	Ø30	42	28.5	G1/8	43	Ø4	9.5	119.4	26.2	22.7	51.7	35.1	34.6	9	58.2	0.2
MD1-V16*-8	Ø8	G1/8	62	Ø30	42	28.5	G1/8	43	Ø4	9.5	119.4	26.2	22.7	51.7	35.1	34.6	9	58.2	0.2
MD1-V16*-10	Ø10	G1/8	67	Ø30	42	28.5	G1/8	43	Ø4	9.5	119.4	26.2	22.7	51.7	35.1	34.6	9	58.2	0.2

Pneumatically operated valves - dimensions



YES1 = pneumatically operated valve, 3/2, monostable, mechanical spring

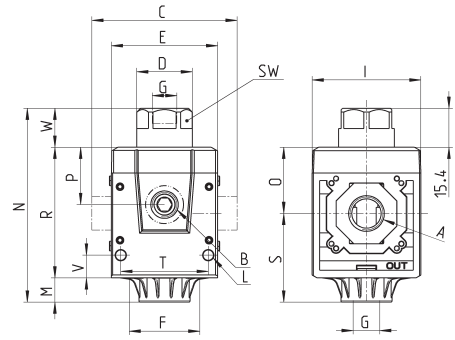
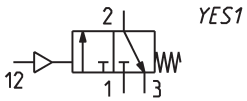

SERIES MD 3/2-WAY ISOLATION VALVES

Mod.	A	B	C	D	E	F	G	I	L	M	N	O	P	R	S	T	V	W	SW	Weight (Kg)
MD1-V36	-	G1/8	42	Ø22	42	28.5	G1/8	43	Ø4	9.5	76.6	26.2	22.7	51.7	35.1	34.6	9	15.4	20	0.2
MD1-V36-1/8	G1/8	G1/8	42	Ø22	42	28.5	G1/8	43	Ø4	9.5	76.6	26.2	22.7	51.7	35.1	34.6	9	15.4	20	0.2
MD1-V36-1/4	G1/4	G1/8	42	Ø22	42	28.5	G1/8	43	Ø4	9.5	76.6	26.2	22.7	51.7	35.1	34.6	9	15.4	20	0.2
MD1-V36-3/8	G3/8	G1/8	42	Ø22	42	28.5	G1/8	43	Ø4	9.5	76.6	26.2	22.7	51.7	35.1	34.6	9	15.4	20	0.2
MD1-V36-6	Ø6	G1/8	47	Ø22	42	28.5	G1/8	43	Ø4	9.5	76.6	26.2	22.7	51.7	35.1	34.6	9	15.4	20	0.2
MD1-V36-8	Ø8	G1/8	62	Ø22	42	28.5	G1/8	43	Ø4	9.5	76.6	26.2	22.7	51.7	35.1	34.6	9	15.4	20	0.2
MD1-V36-10	Ø10	G1/8	67	Ø22	42	28.5	G1/8	43	Ø4	9.5	76.6	26.2	22.7	51.7	35.1	34.6	9	15.4	20	0.2

Series MD soft start valves

Ports with interchangeable cartridges: threaded (1/8, 1/4, 3/8) or integrated with super-rapid fitting for tube with Ø 6, 8 and 10 mm
Modular assembly



- » Security function to maintain the command sequence
- » Opening of the main air path at about 50% of the value of the inlet pressure
- » Upper air intake to connect a pressure switch or to extend switching time
- » Additional air intakes with the same characteristics of the outlet air (line)

The soft start valves are used to avoid the sudden movement of pneumatic actuators. Feeding them pneumatically is enough to begin the phase of the pressure gradual increase in the system. By means of a regulation screw, it is possible to determine the time the valve needs to reach the 50% of the inlet pressure. Once this value is reached, the valve opens completely the passage.

The blanked connection on the upper side allows either the time increase to fill the system through a small additional volume or the connection of a pressure switch.

GENERAL DATA

Construction	modular, compact, poppet-type
Materials	see TABLE OF MATERIALS on the following page
Ports	with interchangeable cartridges: 1/8, 1/4 and 3/8 threaded, integrated with super-rapid fitting for tube with Ø 6, 8 and 10 mm
Fixing	in-line; wall-mounting by means of through hole in the body or with a support bracket
Operating temperature	-5°C ÷ 50°C
Operating pressure	2 ÷ 10 bar
Nominal flow at 6 bar with ΔP 1 bar	MD1-AV-1/8 = 1000 NI/min MD1-AV-1/4 = 1350 NI/min MD1-AV-3/8 = 1500 NI/min
Fluid	compressed air

CODING EXAMPLE

MD	1	-	AV	-	1/8
-----------	----------	---	-----------	---	------------

MD	SERIES
1	DIMENSION: 1 = 42 mm
AV	SOFT START VALVE
1/8	<p>PORTS (IN - OUT)*: = without cartridges</p> <p>1/8 = G1/8 1/4 = G1/4 3/8 = G3/8 6 = tube Ø6 8 = tube Ø8 10 = tube Ø10</p> <p>* NOTE: if the inlet (IN) cartridge is different from the outlet (OUT) cartridge, both dimensions shall be indicated. Example: MD1-AV-1/4-1/8</p>

SERIES MD SOFT START VALVES

Series MD soft start valves - materials

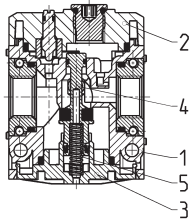

PARTS	MATERIALS
1 = Body	Polyamide
2 = Covering	Polyamide
3 = Plug	Polyamide
4 = Poppet	Brass
5 = Spring	Stainless steel
Seals	NBR

MD1 DIAGRAMS FOR PRESSURISATION TIMES

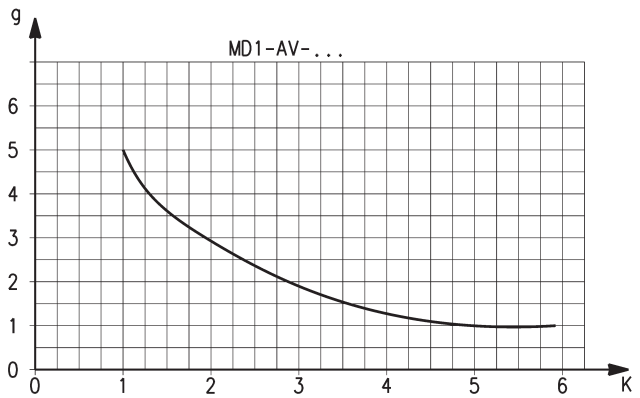
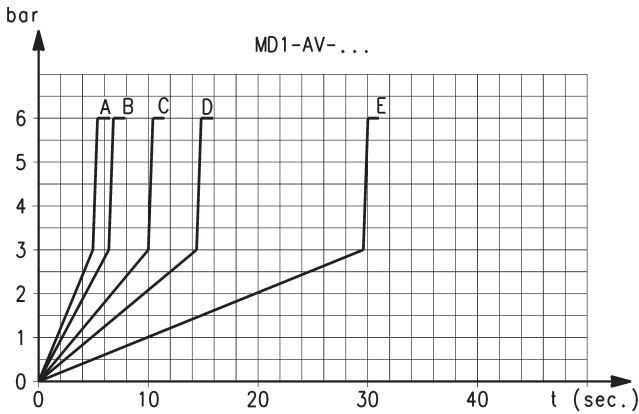

Pressurisation times as to the number of turns of the regulation screw, with downstream volume of 5 litres. A = 5 turns - B = 4 turns - C = 3 turns - D = 2 turns - E = 1 turn. K = number of turns of the regulation screw required to obtain the required pressurisation time with an inlet pressure of 6 bar. Variations of the inlet pressure can cause deviations of the pressure time by ± 20%. $K = t/V$ where: V = volume of the downstream system in litres; t = desired pressuring time in seconds.

EXAMPLE:
 V = 5 litres
 t = 16 seconds
 $K = 16/5 = 3,2$

Using in the graph this value K, the number of turns of the regulation screw will be approx. 0,8.

SERIES MD SOFT START VALVES

Series MD soft start valves - dimensions



AVP1 = Soft start valve

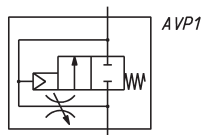
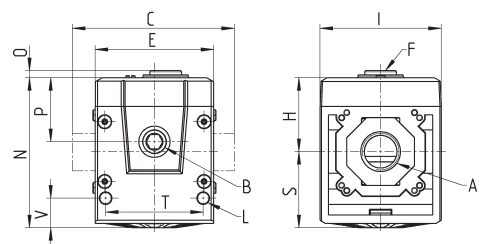

Mod.	A	B	C	E	F	H	I	L	N	O	P	S	T	V	Weight (Kg)
MD1-AV	-	G1/8	42	42	G1/8	26.2	43	Ø4	53.2	2.5	22.7	27	34.6	10.5	0.2
MD1-AV-1/8	G1/8	G1/8	42	42	G1/8	26.2	43	Ø4	53.2	2.5	22.7	27	34.6	10.5	0.2
MD1-AV-1/4	G1/4	G1/8	42	42	G1/8	26.2	43	Ø4	53.2	2.5	22.7	27	34.6	10.5	0.2
MD1-AV-3/8	G3/8	G1/8	42	42	G1/8	26.2	43	Ø4	53.2	2.5	22.7	27	34.6	10.5	0.2
MD1-AV-6	Ø6	G1/8	47	42	G1/8	26.2	43	Ø4	53.2	2.5	22.7	27	34.6	10.5	0.2
MD1-AV-8	Ø8	G1/8	62	42	G1/8	26.2	43	Ø4	53.2	2.5	22.7	27	34.6	10.5	0.2
MD1-AV-10	Ø10	G1/8	67	42	G1/8	26.2	43	Ø4	53.2	2.5	22.7	27	34.6	10.5	0.2

Series MD take-off blocks

Module with interchangeable cartridges: threaded (1/8, 1/4, 3/8) or integrated with super-rapid fitting for tube with Ø 6, 8 and 10 mm (5 outlets) Intermediate junction cartridge (3 outlets) Intermediate junction cartridge with non-return valve

SERIES MD TAKE-OFF BLOCKS



- » Compact design
- » Utilities orientation
- » Cartridge with non-return valve function
- » Power supply block for treatment units mounted on opposite sides

The take-off block can be positioned as desired among the other blocks of the air treatment unit and allows to draw in air from different sides.

The intermediate cartridge, that can also be supplied with a non-return valve, enables to draw in a reduced quantity of air. The take-off block enables to connect two air treatment units that can be mounted on both sides of the block

GENERAL DATA

Construction	modular, compact
Materials	see TABLE OF MATERIALS on the following page
Ports - Take-off block	with interchangeable cartridges: 1/8, 1/4 and 3/8 threaded or integrated with super-rapid fitting for tube with Ø 6, 8 and 10 mm
Ports - Joining cartridge with derivation	3/8
Ports - Joining cartridge with VNR	3/8
Derivations - Take-off block	see dimentions table
Derivations - Joining cartridge	2 x 1/8 + 1 x 3/8
Fixing - Take-off block	in-line; wall-mounting by means of through holes in the body or with a support bracket
Operating temperature	-5°C ÷ 50°C
Operating pressure	0 ÷ 16 bar
Nominal flow at 6 bar with Δp = 1 bar	MD1-B00-1/8 = 1300 NI/min MD1-B00-1/4 = 2300 NI/min MD1-B00-3/8 = 3400 NI/min
Fluid	compressed air

CODING EXAMPLE

MD	1	-	B	00	-	1/8
-----------	----------	----------	----------	-----------	----------	------------

MD	SERIES
1	DIMENSION: 1 = 42 mm
B	TAKE-OFF BLOCK
00	DESIGN TYPE 00 = 5 outlets 01 = 3 outlets (only without cartridges) 02 = Increased inlet
1/8	PORTS (IN - OUT)*: = without cartridges 1/8 = G1/8 1/4 = G1/4 3/8 = G3/8 6 = tube Ø6 8 = tube Ø8 10 = tube Ø10 * NOTE: if the inlet (IN) cartridge is different from the outlet (OUT) cartridge, both dimensions shall be indicated. Example: MD1-B00-3/8-10

SERIES MD TAKE-OFF BLOCKS

Series MD take-off block - materials

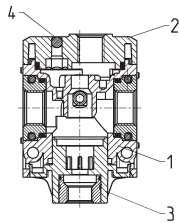

PARTS	MATERIALS
1 = Body	Polyamide
2 = Covering	Polyamide
3 = Plug	Polyamide
4 = Sphere	Stainless steel
Seals	NBR

Take-Off block (5 ways) Mod. MD1-B00

Outlets locations: B (front and rear)
G ; F ; A



BL01 = Take-off block

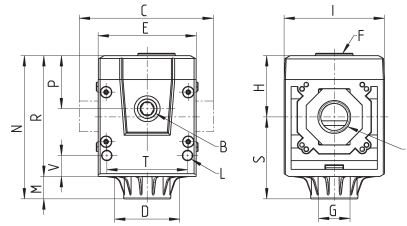

Mod.	A	B	C	D	E	F	G	H	I	L	M	N	P	R	S	T	V	Weight (Kg)
MD1-B00	-	G1/8	42	28.5	42	G1/8	G1/8	26.2	43	Ø4	9.5	61.2	22.7	51.7	35.1	34.6	9	0.2
MD1-B00-1/8	G1/8	G1/8	42	28.5	42	G1/8	G1/8	26.2	43	Ø4	9.5	61.2	22.7	51.7	35.1	34.6	9	0.2
MD1-B00-1/4	G1/4	G1/8	42	28.5	42	G1/8	G1/8	26.2	43	Ø4	9.5	61.2	22.7	51.7	35.1	34.6	9	0.2
MD1-B00-3/8	G3/8	G1/8	42	28.5	42	G1/8	G1/8	26.2	43	Ø4	9.5	61.2	22.7	51.7	35.1	34.6	9	0.2
MD1-B00-6	Ø6	G1/8	47	28.5	42	G1/8	G1/8	26.2	43	Ø4	9.5	61.2	22.7	51.7	35.1	34.6	9	0.2
MD1-B00-8	Ø8	G1/8	62	28.5	42	G1/8	G1/8	26.2	43	Ø4	9.5	61.2	22.7	51.7	35.1	34.6	9	0.2
MD1-B00-10	Ø10	G1/8	67	28.5	42	G1/8	G1/8	26.2	43	Ø4	9.5	61.2	22.7	51.7	35.1	34.6	9	0.2
MD1-B02	-	G1/8	42	28.5	42	G1/8	G1/4	26.2	43	Ø4	9.5	61.2	22.7	51.7	35.1	34.6	9	0.2

Use of the take-off block MD1-B02

The take-off block MD1-B02 is particularly suitable when Series MD1 modules have to be supplied through the same pressure source.
The modules which are connected to the left side are of LH kind.

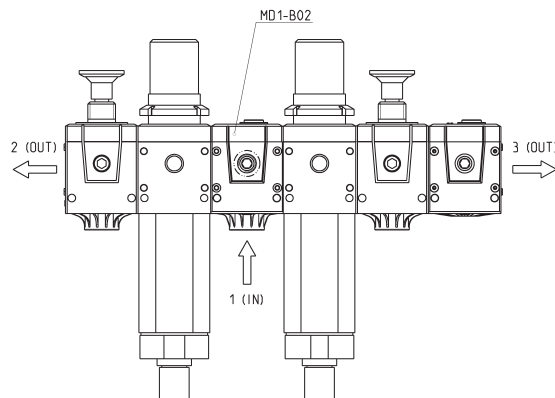

Take-Off block (3 outlets) Mod. MD1-B01



The kit is supplied with:
 1x intermediate joining cartridge with derivation
 4x zinc-plated white special screws $\varnothing 4,5$ TC/RC

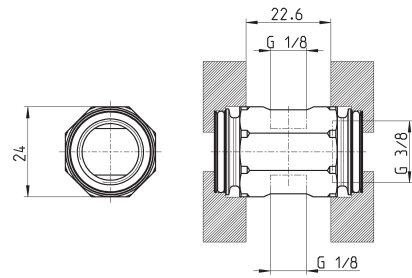

Mod.
MD1-B01

Intermediate joining cartridge with non return valve Mod. MD1-VNR



The kit is supplied with:
 1x intermediate joining cartridge
 with non return valve
 4x zinc-plated white special screws $\varnothing 4,5$ TC/RC

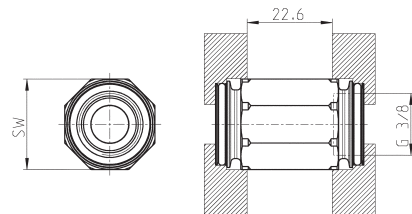

Mod.
MD1-VNR

ACCESSORIES FOR SERIES MD



Threaded cartridges



Integrated cartridges with super-rapid fitting



Intermediate joining cartridge Mod. MD1-C



Screws for wall mounting Mod. MD1-D



Rear bracket Mod. MD1-ST/1

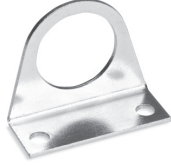

Mounting bracket Mod. C114-ST



Mounting bracket Mod. C114-ST/1



Mounting bracket Mod. C114-ST/2

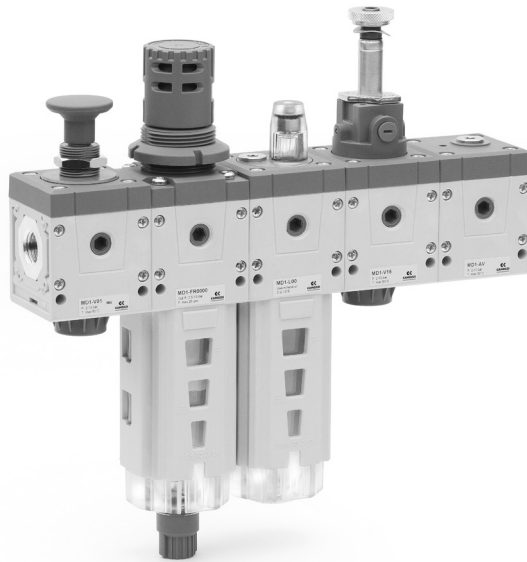

Threaded cartridges Mod. MD1-A-...



The kit is supplied with:
2x nickel-plated threaded cartridges
4x special white zinc-plated screws $\varnothing 4,5$ TC/RC

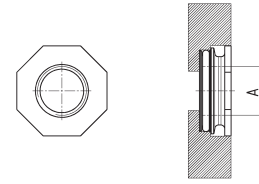

DIMENSIONS	
Mod.	A
MD1-A-1/8	G1/8
MD1-A-1/4	G1/4
MD1-A-3/8	G3/8

Integrated cartridges with super-rapid fitting Mod. MD1-A-...



The kit is supplied with:
2x integrated nickel-plated cartridges with super-rapid fitting
4x special white zinc-plated screws $\varnothing 4,5$ TC/RC

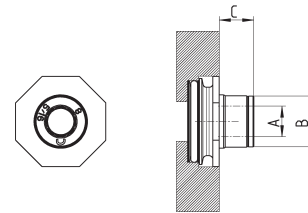

DIMENSIONS			
Mod.	A	B	C
MD1-A-6	$\varnothing 6$	12.7	8.5
MD1-A-8	$\varnothing 8$	14.2	10
MD1-A-10	$\varnothing 10$	16.5	12.5

Intermediate joining cartridge Mod. MD1-C



The kit is supplied with:
1x intermediate joining cartridge
4x special white zinc-plated screws $\varnothing 4,5$ TC/RC

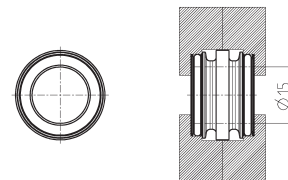

Mod.
MD1-C

Screws for wall mounting Mod. MD1-D

The kit is supplied with:
2x white zinc-plated screws M4x50



Mod.
MD1-D

Rear bracket Mod. MD1-ST/1

The kit is supplied with:
1x zinc-plated bracket
2x white zinc-plated screws M4x50

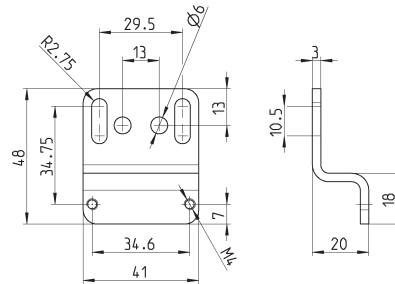

Mod.
MD1-ST/1

Mounting bracket Mod. C114-ST

For regulators and filter-regulators (G1/4 - G1/8)

The kit is supplied with:
1x zinc-plated steel bracket

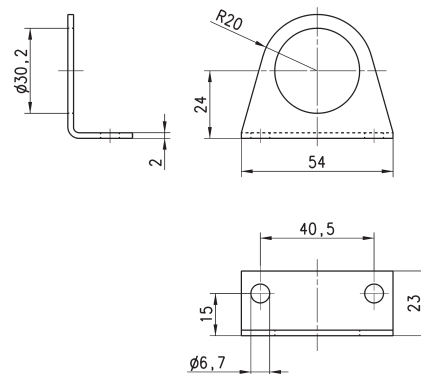
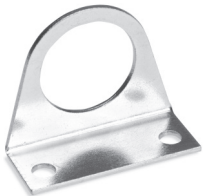

Mod.
C114-ST

Mounting bracket Mod. C114-ST/1



For regulators and filter-regulators (G1/4 - G1/8)

The kit is supplied with:
1x zinc-plated steel bracket

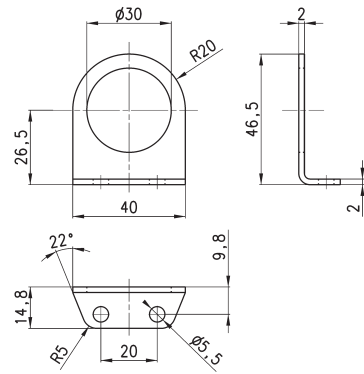

Mod.	
C114-ST/1	

Mounting bracket Mod. C114-ST/2



For regulators and filter-regulators (G1/4 - G1/8)

The kit is supplied with:
1x zinc-plated steel bracket

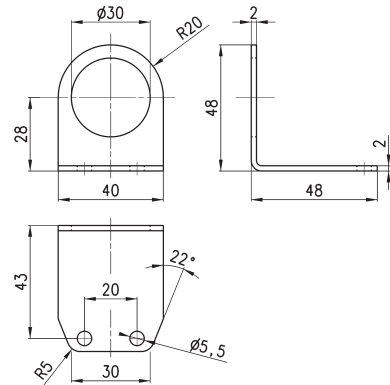

Mod.	
C114-ST/2	

Fixing kit for Series MD: PRE



The kit includes:
1x bushing
1x O-Ring
2x special $\varnothing 4.5 \times 34$ white zinc-plated screws

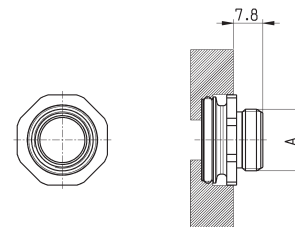

DIMENSIONS	
Mod.	A
PRE-1/4-C	G1/4
PRE-3/8-C	G3/8

Series MD assembled FRL

Ports with interchangeable cartridges: threaded (1/8, 1/4, 3/8) or integrated with super-rapid fitting for tube with Ø 6, 8 and 10 mm
Modular assembly

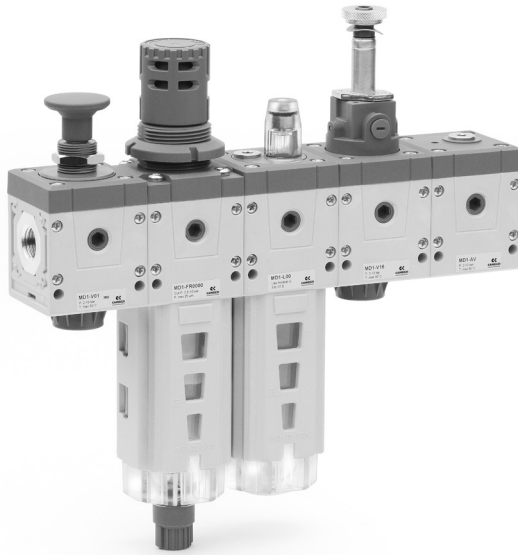

- » Compact design
- » Optimized dimensions
- » Great reliability
- » Easy and quick maintenance
- » Reduced weight
- » Quick fixing
- » Wide range of functions
- » Additional air intakes

The Series MD offers multi-sector solutions that ensure saving in terms of installation time, space and costs. The various functions can be connected by means of intermediate junctioning cartridges. The regulator and the valves can be adjusted so as to have the regulation devices or the actuation in front or lower position. There are different types of wall mounting available.

Thanks to the solution adopted for the pneumatic connection, it is possible to equip the same element with interchangeable cartridges that can either be threaded, or with an integrated super-rapid fitting, both types available in different sizes. Intermediate cartridges can be also integrated to join multiple functions or with derivation to draw air.

GENERAL DATA

Construction	modular, compact
Materials	see catalogue pages referring to the single component
Ports	with interchangeable cartridges: 1/8, 1/4 and 3/8 threaded or integrated with super-rapid fitting for tube with Ø 6, 8 and 10 mm
Fixing	vertical in-line; wall-mounting by means of through holes in the body or with a support bracket; panel mounting
Operating temperature	-5°C ÷ 50°C up to 16 bar (according to the single component characteristics)

CONFIGURATION OF SERIES MD ASSEMBLED GROUPS

TO CONFIGURE THE SERIES MD ASSEMBLED GROUPS, USE THE HERE BELOW EXAMPLE AND THE RELATED LEGEND ON THE FOLLOWING PAGE.

Configuration of the assembled group in the drawing below:

MD1-V01+A26F000L00V16-8

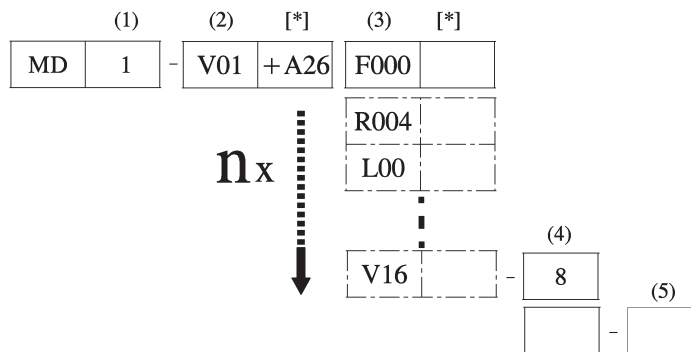
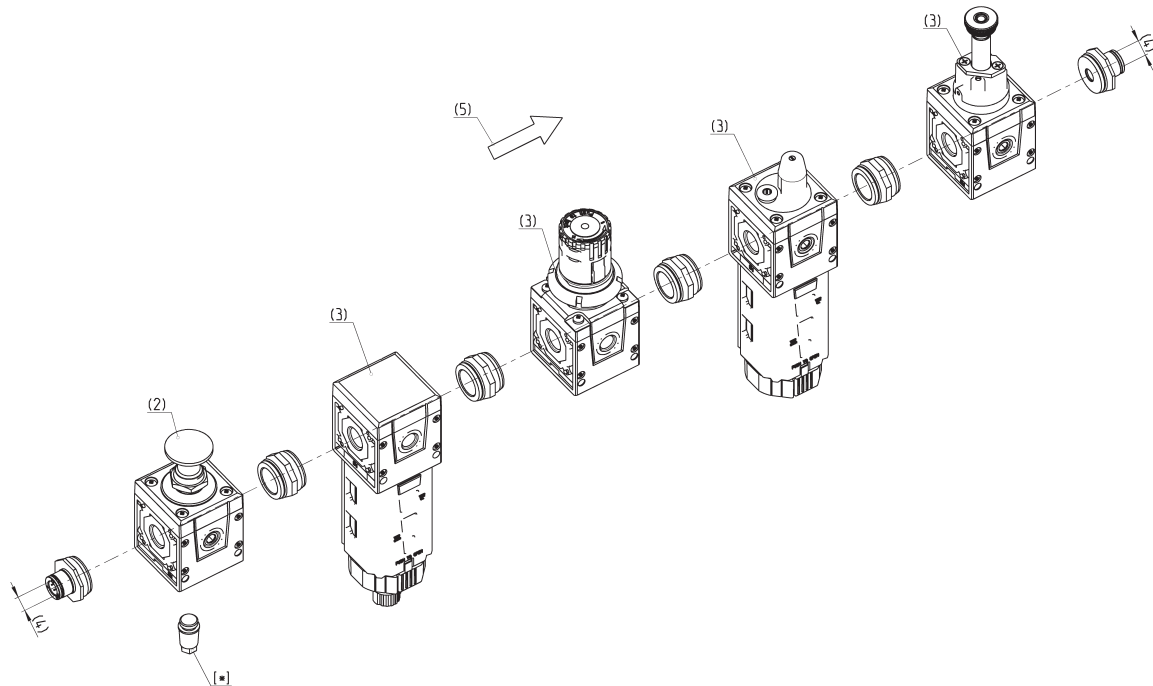

CONFIGURATOR OF SERIES MD ASSEMBLED GROUPS

MD	1	-	V01	F000	R000	L00	V16	-	8	-	LH
-----------	----------	----------	------------	-------------	-------------	------------	------------	----------	----------	----------	-----------

MD		SERIES
1	(1)	DIMENSION: 1 = 42 mm
-		
V01	(2)	MODULE + [*] (to configure the modules, see the single components pages): F... = Filter FC... = Coalescing filter FCA... = Activated carbons filter R... = Pressure regulator L... = Lubricator FR... = Filter-Regulator V... = Lockable isolation valve AV... = Soft start valve B... = Take-off block
	[*]	The following ACCESSORIES can be added after every single module: REGULATOR, FILTER-REGULATOR AND MANIFOLD REGULATOR +A01 = M043-P04 (pressure gauge) +A02 = M043-P06 (pressure gauge) +A03 = M043-P10 (pressure gauge) +A04 = M043-P12 (pressure gauge) +A05 = SWCN-P10-P3-2 (pressure switch) +A06 = SWCN-P10-P4-2 (pressure switch) +A07 = SWCN-P10-P4-M (pressure switch) +A08 = PG010-PB-1/8 (pressure gauge) LOCKABLE ISOLATION VALVE ...V01 / V16 / V36 +A25 = 2901 1/8 (silencier) +A26 = 2921 1/8 (silencier) - recommended choice +A27 = 2931 1/8 (silencier) +A28 = 2938 1/8 (silencier) +A01 = M043-P04 (pressure gauge) +A02 = M043-P06 (pressure gauge) +A03 = M043-P10 (pressure gauge) +A04 = M043-P12 (pressure gauge) +A05 = SWCN-P10-P3-2 (pressure switch) +A06 = SWCN-P10-P4-2 (pressure switch) +A07 = SWCN-P10-P4-M (pressure switch) +A08 = PG010-PB-1/8 (pressure gauge) SOFT START VALVE AND 5-WAY TAKE-OFF BLOCK +A15 = PM11-NC (pressure switch mounted on top) +A16 = PM11-NA (pressure switch mounted on top) +A17 = PM681-1 (pressure switch mounted on top) +A18 = PM681-3 (pressure switch mounted on top) +A19 = PM11-SC + S2520 1/8-1/4 (pressure switch with fitting mounted on top) +A05 = SWCN-P10-P3-2 (front mounted pressure switch) +A06 = SWCN-P10-P4-2 (front mounted pressure switch) +A07 = SWCN-P10-P4-M (front mounted pressure switch) +A08 = PG010-PB-1/8 (front mounted pressure switch) INTERMEDIATE JOINING CARTRIDGE WITH DERIVATION (MD1-B) +A17 = PM681-1 (pressure switch mounted on top) +A18 = PM681-3 (pressure switch mounted on top)
F000	(3)	see MODULE (2) + [*]
R000	(3)	see MODULE (2) + [*]
L00	(3)	see MODULE (2) + [*]
V16	(3)	see MODULE (2) + [*]
-		
8	(4)	PORTS (IN - OUT)**: = without cartridges 1/8 = G1/8 1/4 = G1/4 3/8 = G3/8 6 = tube Ø6 8 = tube Ø8 10 = tube Ø10
-		
LH	(5)	FLOW DIRECTION: = from left to right (standard) LH = from right to left

nx = the combination "(3) + (*)" can be repeated an odd ("n") number of times

** NOTE: if the inlet (IN) cartridge is different from the outlet (OUT) cartridge, both dimensions shall be indicated. Example: MD1-V01F000R000-3/8-8



Series N filters, coalescing filters and activated carbon filters

Ports: G1/8, G1/4



- » Available with: transparent PA12 bowl or nickel-plated brass bowl for the small version (N1)
- » Quality of delivered air according to ISO 8573-1:2010 from Class 7.8.4 to Class 1.7.1

The version with semi-automatic manual drain is equipped with a transparent bowl that makes the monitoring of the condensate level very easy.

The version with metal bowl is particularly suitable for applications subject to impacts or in the presence of aggressive agents that could damage the PA12 bowl.

Series N filters are available with G1/8 and G1/4 gas ports. The models are available with 3 different filtering elements: 25, 5, 0.01µm and activated carbon.

GENERAL DATA

Construction	HDPE, coalescing and activated carbon filtering element
Materials	brass, transparent PA12 or nickel-plated brass, NBR
Ports	G1/8 - G1/4
Max. condensate capacity	11 cm ³ (bowl size = 1) 28 cm ³ (bowl size = 2)
Weight	0.220 kg
Mounting	vertical, inline
Operating temperature	-5°C ÷ 50°C at 10 bar (with the dew point of the fluid lower than 2°C at the min. working temperature)
Quality of delivered air according to ISO 8573-1 2010	Class 7.8.4 with 25 µm filtering element Class 6.8.4 with 5 µm filtering element Class 1.8.1 with 0.01 µm filtering element Classe 1.7.1 with activated carbon filtering element
Draining of condensate	see the coding example
Operating pressure	0.3 ÷ 16 bar (with depressurisation max 10 bar)
Nominal flow	see FLOW DIAGRAMS on the following pages
Fluid	Compressed air
Pre-filtering	it is recommended to use a filter with residual oil of 0.01mg/m ³

CODING EXAMPLE

N	2	04	-	F	0	0	-
----------	----------	-----------	----------	----------	----------	----------	----------

N	SERIES
2	SIZE: 1 = small bowl (11 cm ³) 2 = normal bowl (28 cm ³)
04	PORTS: 08 = G1/8 04 = G1/4
F	F = FILTER
0	FILTERING ELEMENT: 0 = 25µm (standard) 1 = 5µm B = 0.01µm CA = activated carbon (without drain, only closed bowl size 2)
0	DRAINING OF CONDENSATE (further details in the dedicated section): 0 = semi-automatic manual drain 4 = depressurisation (normal bowl only) 5 = protected depressurisation (normal bowl only) 8 = no drain, direct G1/8 exhaust
	BOWL MATERIAL: = transparent PA12 (standard) TM = nickel-plated brass (only in the small size with semi-automatic manual drain or without drain, port 1/8)

Filters Series N



- FT01 = filter without drain with threaded port
- FT02 = filter with semiautomatic manual drain
- FT03 = filter with automatic/depression drain
- FA01 = coalescing filter without drain with threaded port
- FA02 = coalescing filter with semi-automatic manual drain
- FA03 = coalescing filter with automatic/depression drain
- FC01 = absorption function without bowl hole

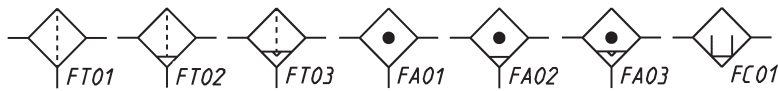
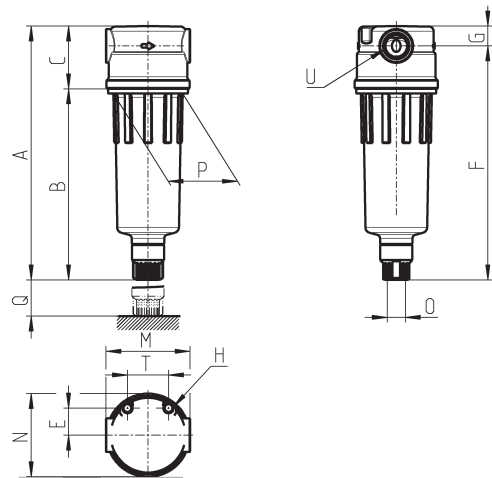

DIMENSIONS														
Mod.	A	B	C	E	F	G	H	M	N	O	P	Q	T	U
N108-F00	111	78	33	14.5	101	10	M5	45	44.5	G1/8	38	40	22	G1/8
N104-F00	111	78	33	14.5	101	10	M5	45	44.5	G1/8	38	40	22	G1/4
N208-F00	135	102	33	14.5	125	10	M5	45	44.5	G1/8	38	40	22	G1/8
N204-F00	135	102	33	14.5	125	10	M5	45	44.5	G1/8	38	40	22	G1/4
N208-FCA	117	84	33	14.5	107	10	M5	45	44.5	G1/8	38	69	22	G1/8
N204-FCA	117	84	33	14.5	107	10	M5	45	44.5	G1/8	38	69	22	G1/4
N108-F19-OX1	93	59	33	14.5	82	10	M5	45	44.5		38	69	22	G1/8
N104-F19-OX1	93	59	33	14.5	82	10	M5	45	44.5		38	69	22	G1/4

FLOW DIAGRAMS

SERIES N FILTERS

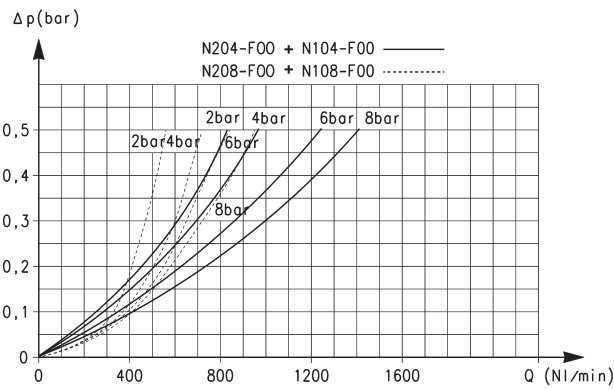

Flow diagram for models:
 N204-F00 - N104-F00 = _____
 N208-F00 - N108-F00 = - - - - -

ΔP = Pressure drop (bar)
 Q = Flow (NL/min)

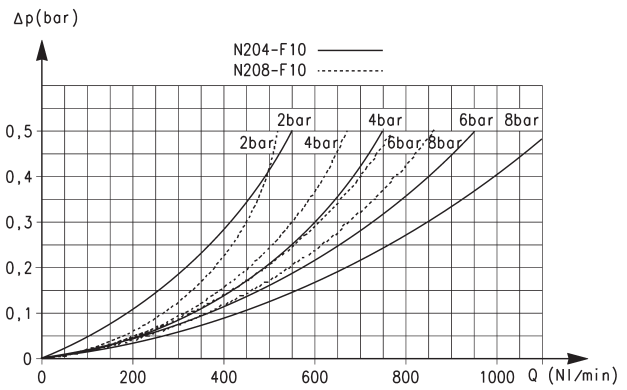

Flow diagram for models:
 N204-F10 = _____
 N208-F10 = - - - - -

ΔP = Pressure drop (bar)
 Q = Flow (NL/min)

FLOW DIAGRAMS

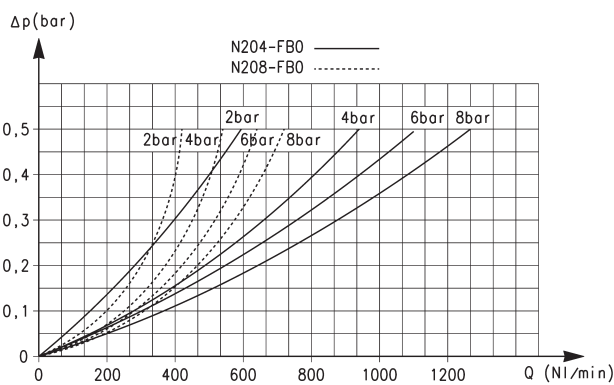

Flow diagram for models:
 N204-FB0 = _____
 N208-FB0 = - - - - -

ΔP = Pressure drop (bar)
 Q = Flow (NL/min)

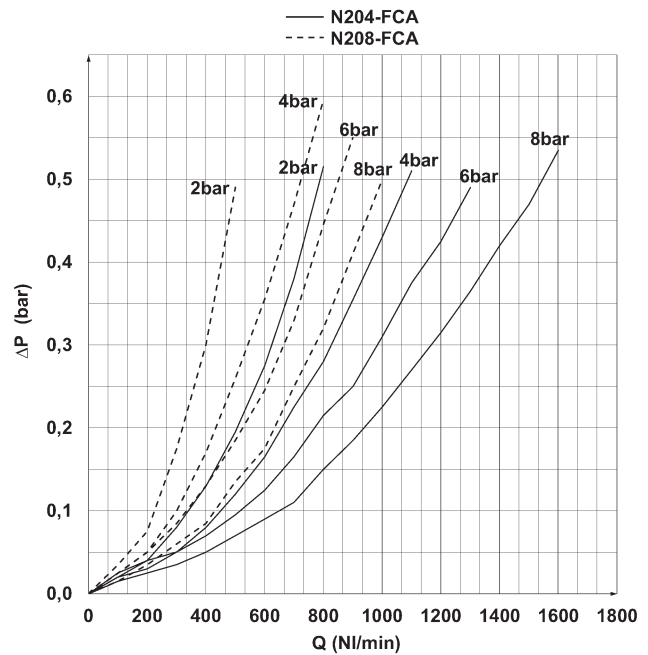

Flow diagram for models:
 N204-FCA = _____
 N208-FCA = - - - - -

ΔP = Pressure drop (bar)
 Q = Flow (NL/min)

Series N pressure regulators

Ports G1/8, G1/4



- » Knob with closure
- » Integral return exhaust (relieving)

Series N pressure regulators are available with G1/4 and G1/8 ports. Their design incorporates a self relieving diaphragm so as to allow decremental adjustments.

GENERAL DATA

Construction	diaphragm type
Materials	brass, technopolymer, NBR
Ports	G1/8 - G1/4
Weight	Kg 0.316
Pressure gauge ports	G1/8
Mounting	in - line or console (in any position)
Operating temperature	-5°C ÷ 50°C (with the dew point of the fluid lower than 2°C at the min. working temperature)
Inlet pressure	0 ÷ 16 bar
Outlet pressure	0.5 ÷ 10 bar(standard), 0.5 ÷ 2 bar; 0.5 ÷ 4 bar e 0.5 ÷ 7 bar
Nominal flow	see FLOW DIAGRAMS on the following pages
Secondary pressure relieving	with relieving (standard) without relieving
Fluid	compressed air

CODING EXAMPLE

N	12	04	-	R	T	0	-	■	-	●
---	----	----	---	---	---	---	---	---	---	---

N	SERIES
12	SIZE: 12
04	PORTS: 08 = G1/8 04 = G1/4
R	R = REGULATOR
T	OPERATING PRESSURE: 0 = 0.5 ÷ 10 bar (standard) 1 = 0.5 ÷ 4 bar 2 = 0.5 ÷ 2 bar 7 = 0.5 ÷ 7 bar T = calibrated* B = locked*
0	DESIGN TYPE: 0 = self-relieving 1 = non-relieving
<p>* NOTE: IF THE REGULATOR IS CALIBRATED OR LOCKED, AFTER THE DESIGN TYPE ADD THE INLET PRESSURE "■" AND THE OUTLET PRESSURE "●"</p> <p>INLET PRESSURE: ■ = enter the SUPPLY pressure value</p> <p>OUTLET PRESSURE: ● = enter the OUTLET pressure value for the LOCKED regulator or the maximum value of the ADJUSTABLE pressure for the CALIBRATED regulator</p> <p>Example of a calibrated regulator with Inlet Pressure = 6.3 bar and Outlet Pressure = 4.5 bar Complete part number: N1204-RT0-6.3-4.5</p>	

Pressure regulators Series N



Calibrated or blocked regulators on request

PR01 = regulator without relieving
PR02 = regulator with relieving

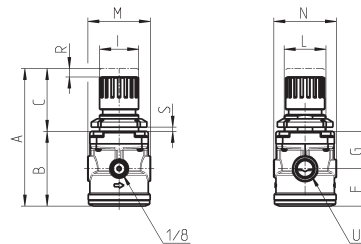
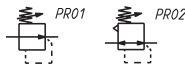

DIMENSIONS												
Mod.	A	B	C	F	G	I	L	M	N	R	S	U
N1208-R00	92	53	39	26	27	28	30X1,5	45	45	3	0+6	G1/8
N1204-R00	92	53	39	26	27	28	30X1,5	45	45	3	0+6	G1/4

FLOW DIAGRAMS

SERIES N PRESSURE REGULATORS

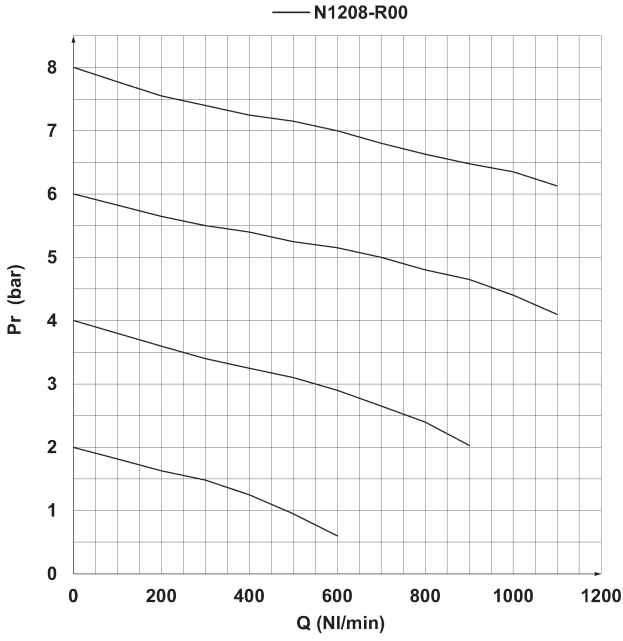

Flow diagram for model: N1208-R00

Pa = Inlet pressure (bar)
Pr = Regulated pressure (bar)
Q = Flow (NL/min)

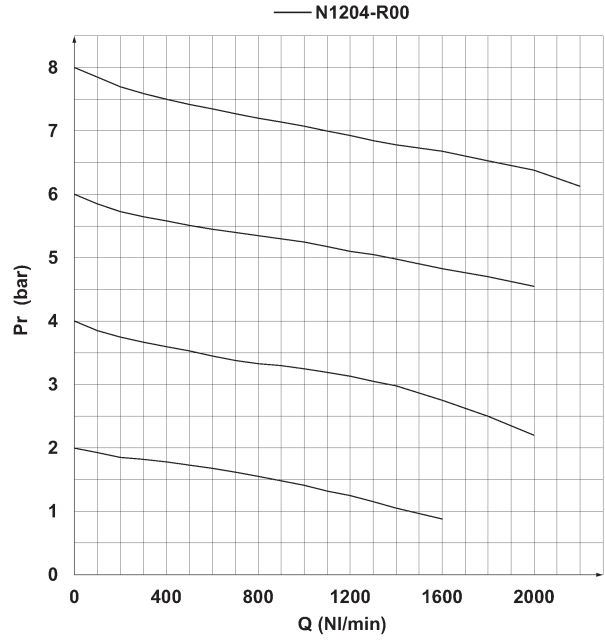

Flow diagram for model: N1204-R00

Pa = Inlet pressure (bar)
Pr = Regulated pressure (bar)
Q = Flow (NL/min)

Series N lubricators

New version

Ports G1/8, G1/4



» Available with: transparent PA12 bowl or nickel-plated brass bowl for the small version (N1)

Series N lubricators are available with G1/4 and G1/8 ports. The special type of design allows a vast range of applications in relation to the amount of atomized oil and the air consumed.

The body is made of brass, whilst the bowl can be in transparent PA12 or in nickel-plated brass.

The version with metal bowl is particularly suitable for applications subject to impacts or in the presence of aggressive agents that could damage the PA12 bowl.

GENERAL DATA

Construction	modular, compact
Materials	brass, transparent PA12 or nickel-plated brass, NBR
Ports	G1/8 - G1/4
Oil capacity	26 cm ³ (bowl size = 1) 37 cm ³ (bowl size = 2)
Weight	0.240 kg
Mounting	vertical, inline
Operating temperature	-5°C ÷ 50°C at 10 bar (with the dew point of the fluid lower than 2°C at the min. working temperature)
Oil refilling	without pressure
Oil for lubricator	use ISO VG32 oils. Once applied, the lubrication should never be interrupted
Operating pressure	1 ÷ 16 bar
Nominal flow	see FLOW DIAGRAMS on the following pages
Min. air consumption for lubrication	at 1 bar = 7.5 NL/min at 6 bar = 11 NL/min
Fluid	compressed air

CODING EXAMPLE

N	2	04	-	L	00	-	
----------	----------	-----------	----------	----------	-----------	----------	--

N	SERIES
2	SIZE: 1 = small bowl (26 cm ³) 2 = normal bowl (37 cm ³)
04	PORTS: 08 = G1/8 04 = G1/4
L	L = LUBRICATOR
00	DESIGN TYPE: 00 = atomized oil
	BOWL MATERIAL: = transparent PA12 (standard) TM = nickel-plated brass (only in the small size)

SERIES N LUBRICATORS

Lubricators Series N



LU0 = Lubricator

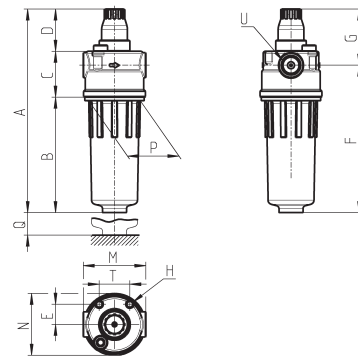
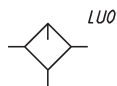

DIMENSIONS															
Mod.	A	B	C	D	E	F	G	H	M	N	P	Q	T	U	
N108-L00	122.5	59	33	30.5	14.5	82	40.5	M5	45	44.5	38	46.5	22	G1/8	
N104-L00	122.5	59	33	30.5	14.5	82	40.5	M5	45	44.5	38	46.5	22	G1/4	
N208-L00	146.5	83	33	30.5	14.5	106	40.5	M5	45	44.5	38	46.5	22	G1/8	
N204-L00	146.5	83	33	30.5	14.5	106	40.5	M5	45	44.5	38	46.5	22	G1/4	

FLOW DIAGRAMS

SERIES N LUBRICATORS

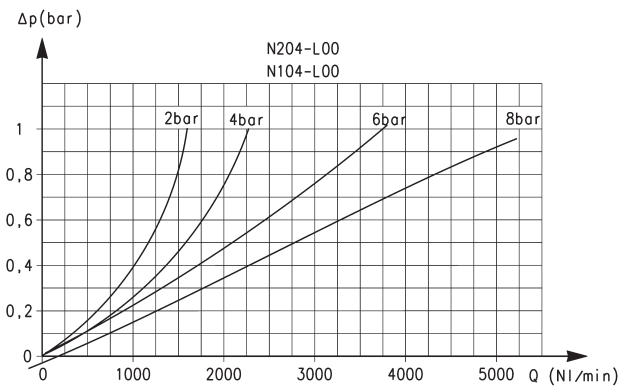

Flow diagrams for models: N204-L00 and N104-L00

ΔP = Pressure drop (bar)
Q = Flow (NL/min)

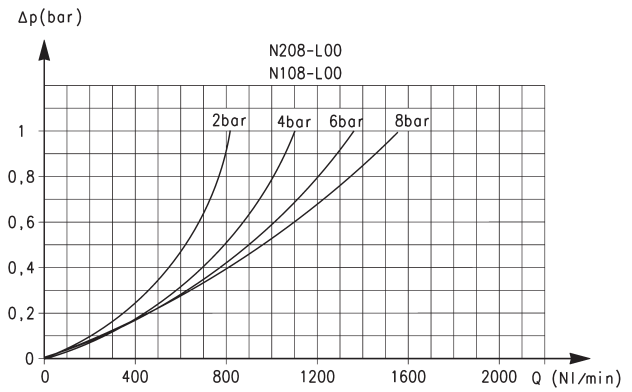

Flow diagrams for models: N208-L00 and N108-L00

ΔP = Pressure drop (bar)
Q = Flow (NL/min)

Series N filter-regulators

Ports G1/8, G1/4



» Available with: transparent PA12 bowl or nickel-plated brass bowl for the small version (N1)

The version with metal bowl is particularly suitable for applications subject to impacts or in the presence of aggressive agents that could damage the PA12 bowl.

Series N filter-regulator is available with G1/4 and G1/8 ports. Its design incorporates a self relieving diaphragm. The transparent filter bowl allows an easy monitoring of the condensate level. The semi-automatic manual drain makes both the manual and automatic condensate exhaust easier when there is no pressure.

GENERAL DATA

Construction	HDPE and coalescing filtering element
Materials	brass body and poppet stainless steel spring NBR O-ring HDPE filtering element transparent PA12 or nickel-plated bowl others: PA
Ports	G1/8 - G1/4
Max. condensate capacity	11 cm ³ (bowl size = 1) 28 cm ³ (bowl size = 2)
Weight	0.370 Kg
Pressure gauge ports	G1/8
Mounting	vertical, in-line
Operating temperature	-5°C ÷ 50°C a 10 bar (with the dew point of the fluid lower than 2°C at the min. working temperature)
Quality of delivered air according to ISO 8573-1 2010	Class 7.8.4 with 25 µm filtering element Class 6.8.4 with 5 µm filtering element
Draining of condensate	see the coding example
Inlet pressure	with standard drain and protected depressurisation 0.3 ÷ 16 bar
Outlet pressure	with depressurisation drain 0.3 ÷ 10 bar
Nominal flow	see FLOW DIAGRAMS on the following pages
Secondary pressure relieving	with relieving (standard) without relieving
Fluid	compressed air

CODING EXAMPLE

N	2	04	-	D	0	0	-	4	-
N	SERIES								
2	SIZE: 1 = small bowl (11 cm ³) 2 = normal bowl (28 cm ³)								
04	PORTS: 08 = G1/8 04 = G1/4								
D	D = FILTER-REGULATOR								
0	FILTERING ELEMENT: 0 = 25µm (standard) 1 = 5µm								
0	DRAINING OF CONDENSATE (further details in the dedicated section) AND DESIGN TYPE: 0 = semi-automatic manual drain with self-relieving 1 = semi-automatic manual drain without relieving 4 = depressurisation with self-relieving (with normal bowl only) 5 = protected depressurisation with self-relieving (with normal bowl only) 8 = no drain (direct port 1/8), with self-relieving								
4	OPERATING PRESSURE: = 0.5 ÷ 10 bar (standard) 2 = 0.5 ÷ 2 bar 4 = 0.5 ÷ 4 bar 7 = 0.5 ÷ 7 bar								
	BOWL MATERIAL: = transparent PA12 (standard) TM = nickel-plated brass (only in the small size with semi-automatic manual drain or without drain)								

SERIES N FILTER-REGULATORS

Series N filter-regulators



FR01 = filter-regulator with relieving and manual drain
 FR02 = FR with relieving and without drain
 FR11 = FR with manual drain and without relieving

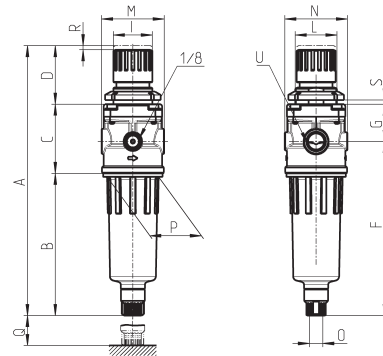
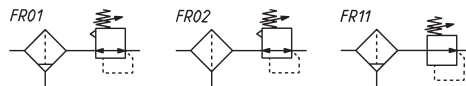

Mod.	A	B	C	D	F	G	I	L	M	N	O	P	Q	R	S	U
N108-D00	167	78	50	39	101	27	28	M30x1,5	45	45	G1/8	38	40	3	0 ÷ 6	G1/8
N104-D00	167	78	50	39	101	27	28	M30x1,5	45	45	G1/8	38	40	3	0 ÷ 6	G1/4
N208-D00	191	102	50	39	125	27	28	M30x1,5	45	45	G1/8	38	40	3	0 ÷ 6	G1/8
N204-D00	191	102	50	39	125	27	28	M30x1,5	45	45	G1/8	38	40	3	0 ÷ 6	G1/4
N104-D19-OX1	147	59	50	39	82	27	28	M30x1,5	45	45		38	40	3	0 ÷ 6	G1/4
N108-D19-OX1	147	59	50	39	82	27	28	M30x1,5	45	45		38	40	3	0 ÷ 6	G1/8

FLOW DIAGRAMS

SERIES N FILTER-REGULATORS

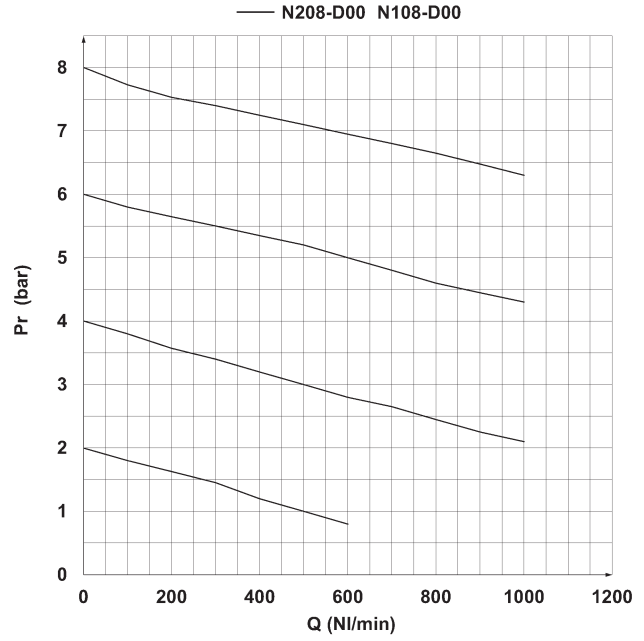
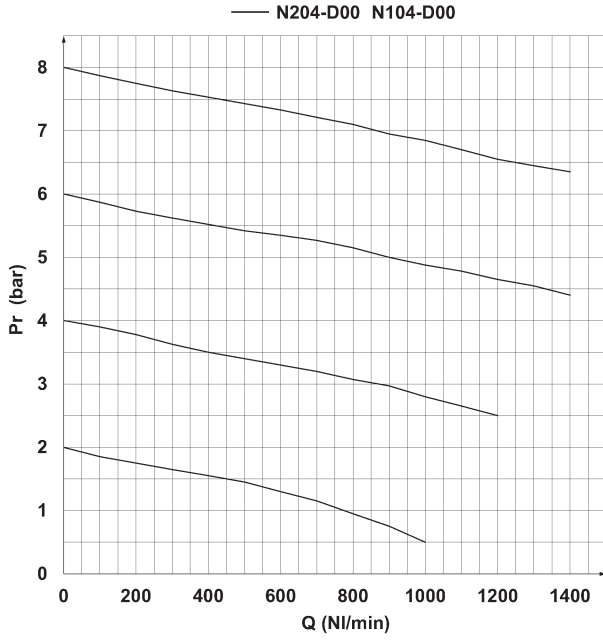

Flow diagrams for models: N204-D00 - N104-D00

Pa = Inlet pressure (bar)
Pr = Regulated pressure (bar)
Qn = Flow (NL/min)

Flow diagrams for models: N208-D00 - N108-D00

Pa = Inlet pressure (bar)
Pr = Regulated pressure (bar)
Qn = Flow (NL/min)

ACCESSORIES FOR SERIES N

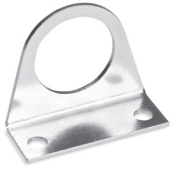

Mounting bracket
Mod. C114-ST



Mounting bracket
Mod. C114-ST/1



Mounting bracket
Mod. C114-ST/2



Mounting bracket
Mod. N204-ST



Systems of rapid connections designed to make mounting easier.

Mounting bracket Mod. C114-ST



For regulators and filter-regulators (G1/4 - G1/8)

The kit is supplied with:
1x zinc-plated steel bracket.

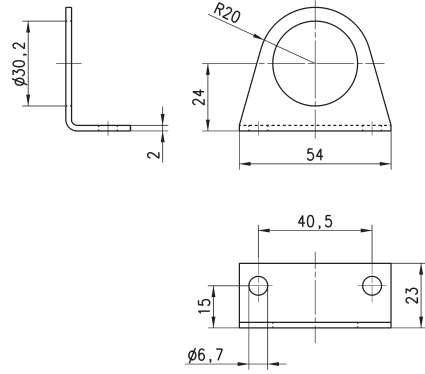

Mod.
C114-ST

Mounting bracket Mod. C114-ST/1



For regulators and filter-regulators (G1/4 - G1/8)

The kit is supplied with 1 zinc-plated steel bracket.

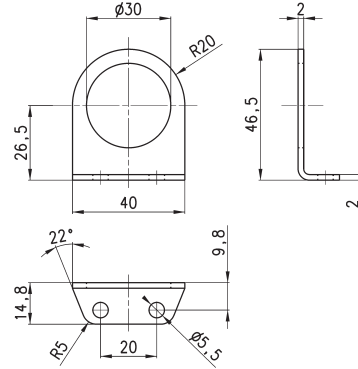

Mod.
C114-ST/1

Mounting bracket Mod. C114-ST/2



For regulators and filter-regulators
(G1/4 - G1/8)

The kit is supplied with 1 zinc-plated steel bracket.

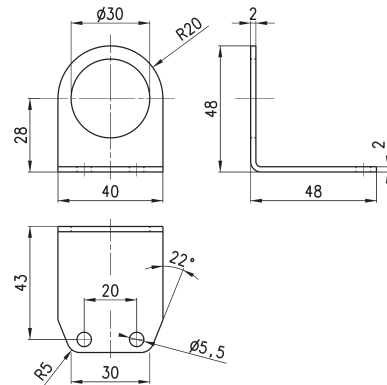

Mod.
C114-ST/2

Mounting bracket Mod. N204-ST



For filters and lubricators

The kit is supplied with:

- 1 bracket
- 2 screws M5X6

Materials: zinc-plated steel bracket and screws.

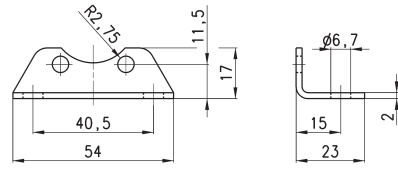

Mod.

N204-ST

Series CLR micro pressure regulators

Ports G1/4, G1/8
With banjo stem with or without relieving
Available with or without banjo



Series CLR micro pressure regulators are available with G1/8 and G1/4 connections. A piston with or without relieving and VS function (by-pass valve) has been incorporated into its design. The body is in brass, while the connection fitting is in technopolymer which guarantees maximum lightness. They can be supplied with or without banjo and can be console mounted.

With a threaded top part of the body both direct mounting to a valve outlet (1/8 and 1/4 threads) and console mounting are easily facilitated. The pressure is precisely regulated simply by turning the polymer knob with a locking nut available to set the desired output.

- » Extremely lightweight
- » Compact
- » In-line or console mounting

GENERAL DATA

Construction	piston
Materials	brass body, technopolymer banjo, stainless steel spring; NBR O-ring
Ports	G1/8 - G1/4
Weight	Kg 0,035
Mounting	in-line or panel mounting (in any position)
Operating temperature	-5°C ÷ 50°C (with the dew point of the fluid lower than 2°C at the min. working temperature)
Inlet pressure	2 ÷ 10 bar
Outlet pressure	0,5 ÷ 10 bar
Nominal flow	see FLOW DIAGRAMS on the following pages
Secondary pressure (relieving)	with relieving (standard) without relieving (all regulators are provided with high relief flow VS function)
Fluid	compressed air

CODING EXAMPLE

CL	R		1/8	-	01	-	4
CL	SERIES:						
R	R = REGULATOR						
1/8	PORTS: 1/8 = G1/8 1/4 = G1/4						
01	DESIGN TYPE: = with relieving 01 = without relieving						
4	TUBE: = without banjo 4 = single technopolymer banjo with tube diameter Ø4 mm (only CLR 1/8) 6 = single technopolymer banjo with tube diameter Ø6 mm 8 = single technopolymer banjo with tube diameter Ø8 mm 1/8L = single metal banjo with thread G1/8 (only CLR 1/8) 1/8D = double metal banjo with double thread G1/8 (only CLR 1/8)						

SERIES CLR MICRO PRESSURE REGULATORS

FLOW DIAGRAMS at 6 bar with ΔP1

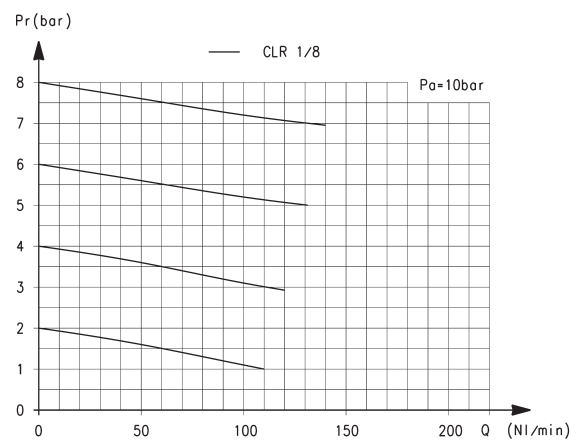
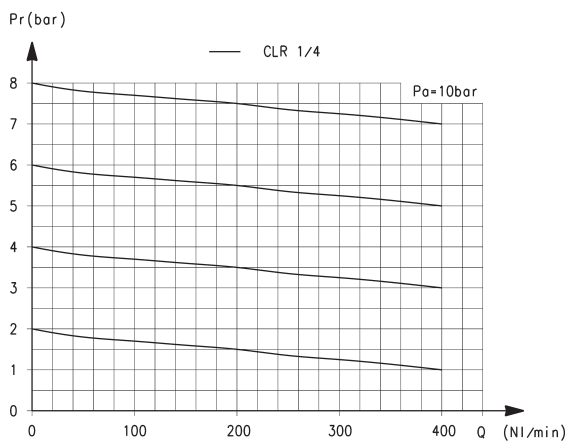

Pa = Inlet pressure (bar)
Pr = Regulated pressure (bar)
Q = Flow (NL/min)

CLR 1/4-6 = 209 NL/min
CLR 1/4-8 = 310 NL/min

Pa = Inlet pressure (bar)
Pr = Regulated pressure (bar)
Q = Flow (NL/min)

CLR 1/8-4 = 90 NL/min
CLR 1/8-6 = 120 NL/min
CLR 1/8-8 = 120 NL/min

Series CLR Micro pressure regulators with banjo

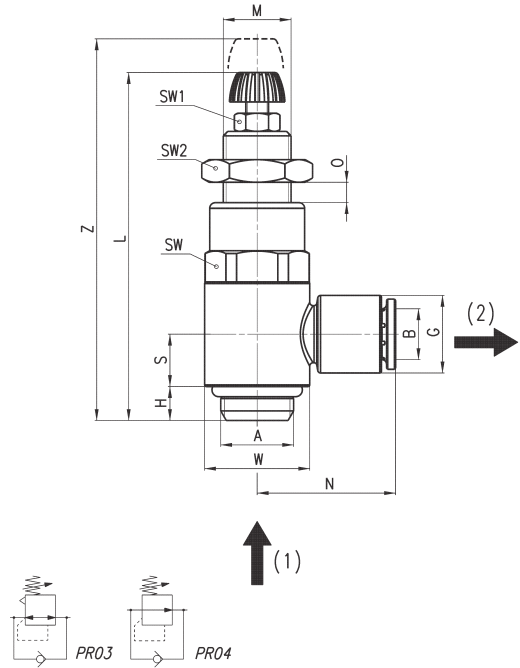

Mod.	A	B	G	H	L	M	N	O	S	W	SW	SW1	SW2	Z
CLR 1/8-4	G1/8	4	11.6	5	52	M11x1	21	0 ÷ 6.5	7.75	14	14	7	14	59
CLR 1/8-6	G1/8	6	11.6	5	52	M11x1	21	0 ÷ 6.5	7.75	14	14	7	14	59
CLR 1/8-8	G1/8	8	13.9	5	52	M11x1	22.5	0 ÷ 6.5	7.75	14	14	7	14	59
CLR 1/4-6	G1/4	6	13.9	6	59.5	M12x1	24.5	0 ÷ 8	9.25	18.6	17	7	17	68
CLR 1/4-8	G1/4	8	13.9	6	59.5	M12x1	24.5	0 ÷ 8	9.25	18.6	17	7	17	68

DRAWING NOTE
(1) = inlet pressure
(2) = regulated pressure

PR03 = Regulator with relieving and by-pass valve
PR04 = Regulator without relieving and with by-pass valve

Series CLR Micro pressure regulators without banjo

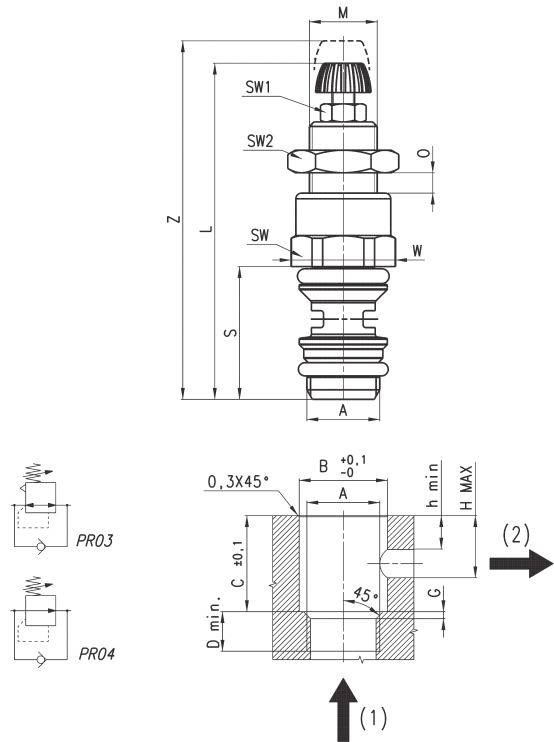

DIMENSIONS																
Mod.	A	B	C	D min	G	h min	H MAX	L	M	O	S	W	SW	SW1	SW2	Z
CLR 1/8	G1/8	11	15.5	6	1	5.5	10	52	M11x1	0 ÷ 6.5	20.5	15.2	14	7	14	59
CLR 1/4	G1/4	15.65	18.5	7	1.25	7	12	59.5	M12x1	0 ÷ 8	24.5	18.5	17	7	17	68

DRAWING NOTE
(1) = inlet pressure
(2) = regulated pressure

PR03 = Regulator with relieving and by-pass valve
PR04 = Regulator without relieving and with by-pass valve

Series CLR Micro pressure regulators with double banjo

New model

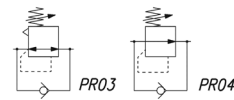
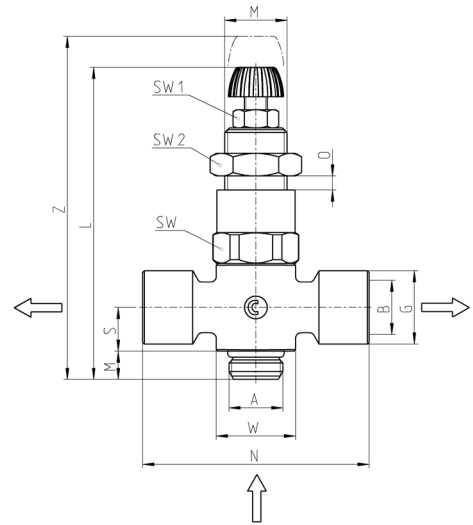

DRAWING NOTE
(1) = inlet pressure
(2) = regulated pressure

PR03 = Regulator with relieving and by-pass valve
PR04 = Regulator without relieving and with by-pass valve

Mod.	A	B	G	H	L	M	N	O	S	W	SW	SW1	SW2	Z
CLR 1/8-1/8D	G1/8	G1/8	13	5	52	M11x1	40	0 ÷ 6.5	7.75	14	14	7	14	59

Series CLR Micro pressure regulators with banjo

New model

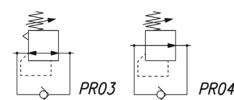
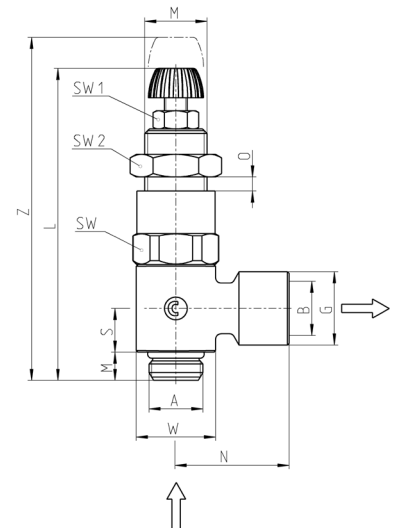

DRAWING NOTE
(1) = inlet pressure
(2) = regulated pressure

PR03 = Regulator with relieving and by-pass valve
PR04 = Regulator without relieving and with by-pass valve

Mod.	A	B	G	H	L	M	N	O	S	W	SW	SW1	SW2	Z
CLR 1/8-1/8L	G1/8	G1/8	13	5	52	M11x1	20	0 ÷ 6.5	7.75	14	14	7	14	59

Series TC pressure microregulators

For applications with oxygen, without relieving
Ports: cartridge construction, G1/8 and 1/8 NPTF

SERIES TC MICROREGULATORS



- » Compact design
- » High performance
- » Easy to install
- » Materials suitable with several gases

The Series TC pressure regulator has been designed to be used for all the applications and equipment where it is needed to insert the single component in customized integrated pneumatic circuits (manifolds) or collectors.

The cartridge design and the compact size allow the regulator to be plugged in a proper seat, making the installation easier and reducing the assembly time. To produce the new TC regulator, materials have been analyzed and chosen on the basis of their suitability with the contact medium. The body in PPS and the seals in FKM ensure thus full compatibility with a wide range of gaseous fluids.

GENERAL DATA

Construction	compact with pre-formed diaphragm
Materials	see the TABLE OF MATERIALS on the following page
Ports	cartridge construction in manifold - G1/8 or 1/8NPTF (aluminium body version only)
Mounting	in-line or cartridge (any position)
Operating temperature	-5°C ÷ 50°C
Inlet pressure	0 ÷ 10 bar
Outlet pressure	0.03 ÷ 0.5 bar 0.1 ÷ 2 bar 0.15 ÷ 3 bar 0.2 ÷ 4 bar
Overpressure exhaust	without relieving
Nominal flow	see FLOW DIAGRAMS on the following pages
Medium	air, inert and medical gases, OXYGEN
Repeatability	±0.2% FS

CODING EXAMPLE

TC	1	-	R	3	1	-	C	-	V	-	OX2
-----------	----------	----------	----------	----------	----------	----------	----------	----------	----------	----------	------------

TC	SERIES
1	SIZE
R	REGULATOR
3	WORKING PRESSURE: 1 = 0.03 ÷ 0.5 bar 2 = 0.1 ÷ 2 bar 3 = 0.15 ÷ 3 bar 4 = 0.2 ÷ 4 bar
1	TYPE OF CONSTRUCTION: 1 = without relieving
C	PORTS: C = Cartridge 1/8 = G1/8 1/8TF = 1/8NPTF
V	SEALS MATERIAL: V = FKM
OX2	VERSIONS: OX1 = for oxygen (non-volatile residue lower than 550 mg/m ³) OX2 = for oxygen (non-volatile residue lower than 35 mg/m ³)

SERIES TC MICROREGULATORS

Series TC pressure microregulators - materials

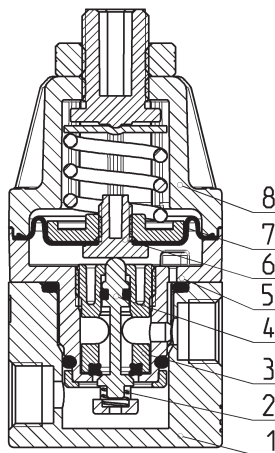

PARTS	MATERIALS
1. Base body	Anodized aluminium
2. Lower spring	Stainless steel
3. Insert	PPS
4. Poppet	Stainless steel
5. Body	PPS
6. Valve guide	PPS
7. Diaphragm	FKM
8. Bell	Polyamide
Seals	FKM

FLOW DIAGRAMS - 0.5 and 2 bar working pressure

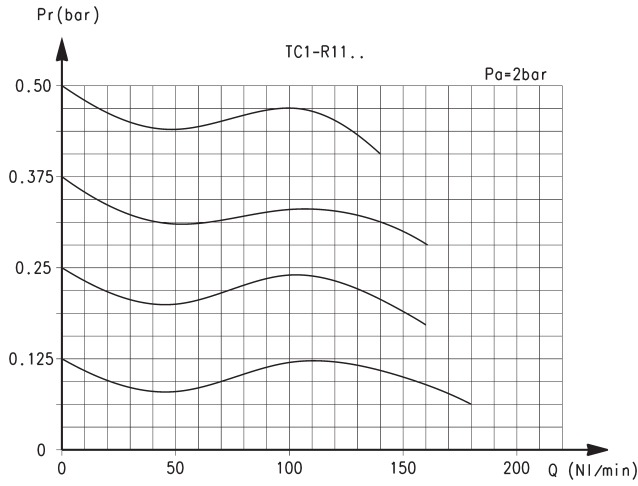

Pr = Regulated pressure (bar)
Q = Flow (NI/min)

Pa = Inlet pressure (bar)

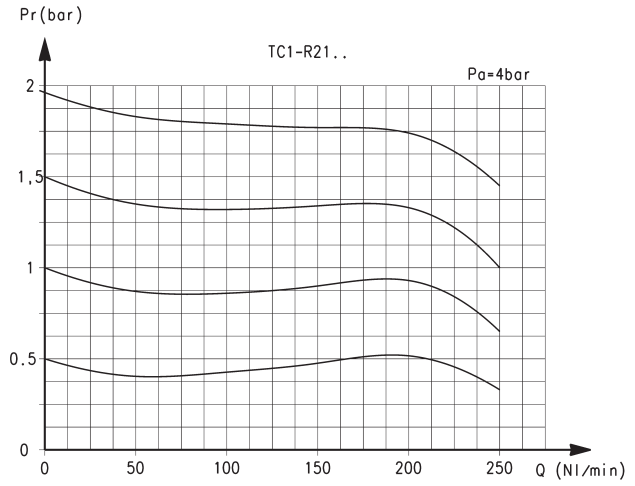

Pr = Regulated pressure (bar)
Q = Flow (NI/min)

Pa = Inlet pressure (bar)

FLOW DIAGRAMS - 3 and 4 bar working pressure

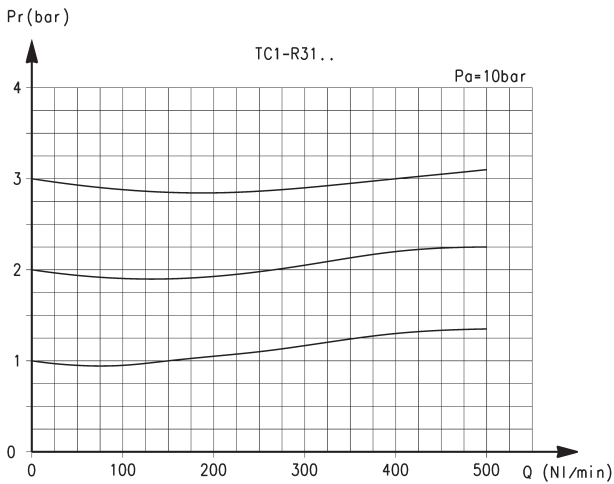

Pr = Regulated pressure (bar)
Q = Flow (NI/min)

Pa = Inlet pressure (bar)

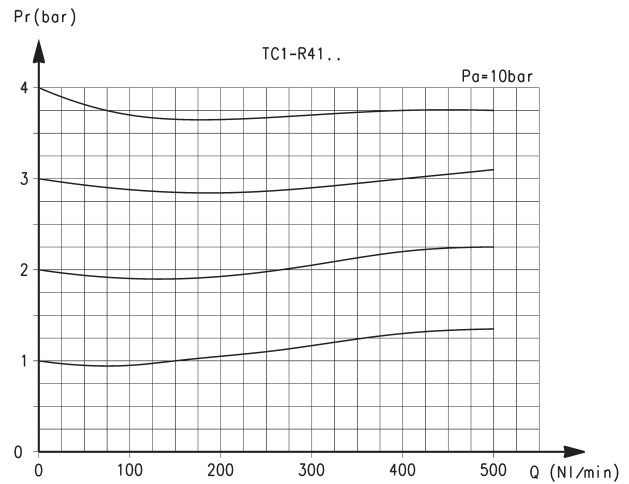

Pr = Regulated pressure (bar)
Q = Flow (NI/min)

Pa = Inlet pressure (bar)

Series TC cartridge pressure microregulators

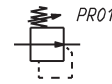
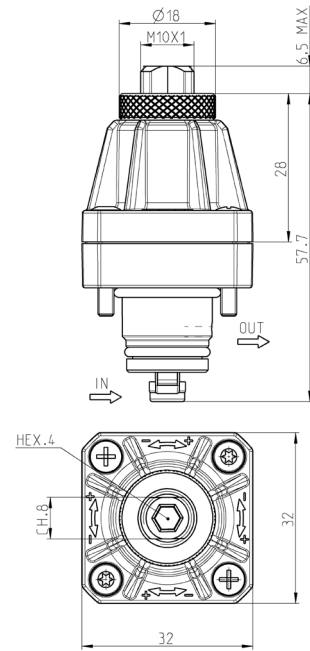

PR01 = regulator without relieving

Mod.

TC1-R11-C-V-OX1

TC1-R11-C-V-OX2

TC1-R21-C-V-OX1

TC1-R21-C-V-OX2

TC1-R31-C-V-OX1

TC1-R31-C-V-OX2

TC1-R41-C-V-OX1

TC1-R41-C-V-OX2

Series TC pressure microregulators with aluminium body



* to choose the type of thread (G1/8 or 1/8 NPTF)
see the Coding example

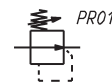
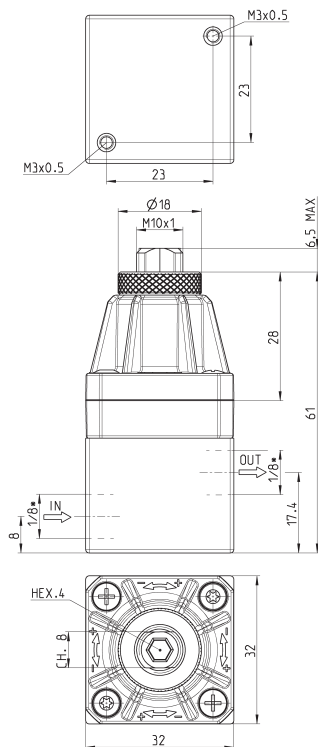

PR01 = regulator without relieving

Mod.

TC1-R11- V -OX1

TC1-R11- V -OX2

TC1-R21- V -OX1

TC1-R21- V -OX2

TC1-R31- V -OX1

TC1-R31- V -OX2

TC1-R41- V -OX1

TC1-R41- V -OX2

Seat dimensions for cartridge version

SERIES TC MICROREGULATORS

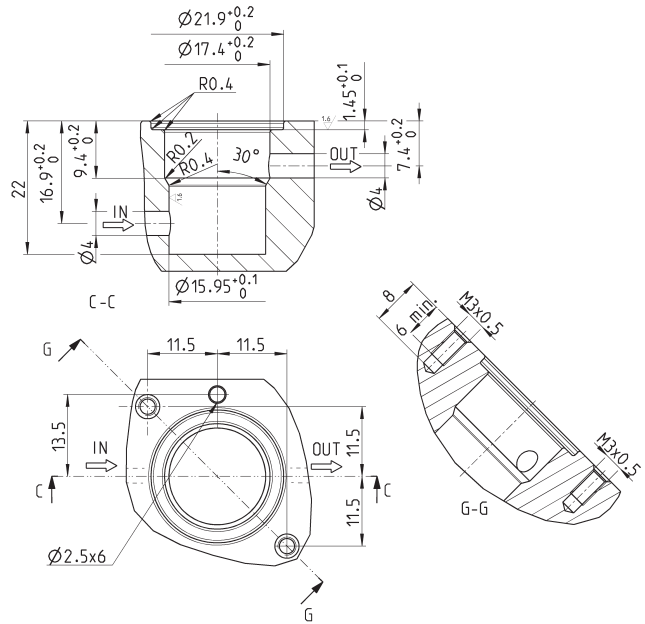

Series M pressure microregulators

Ports G1/8, G1/4



- » Versions with calibrated or blocked regulators are available
- » Versions with certified diaphragms and seals materials are available on request

Series M pressure regulator is available with G1/8 and G1/4 ports. Its design incorporates a diaphragm and relieving so as to allow decremental adjustments as well.

Microregulators are available with different regulation types: non-relieving, very sensitive self-relieving (through a light air leak) and VS (valve with fast draining).

The VS version is used when a regulator should be inserted between the valve and cylinder, or capacity, without any negative influence on the exhaust.

GENERAL DATA

Construction	diaphragm type
Materials	brass body, stainless steel spring, NBR O-ring
Ports	G1/8 - G1/4
Weight	Kg 0.235
Pressure gauge ports	G1/8
Mounting	in-line or panel mounting (in any position)
Operating temperature	-5°C ÷ 50°C (with the dew point of the fluid lower than 2°C at the min. working temperature)
Inlet pressure	0 ÷ 16 bar
Outlet pressure	0.5 ÷ 10 bar (standard) 0.5 ÷ 2 bar 0.5 ÷ 4 bar 0.5 ÷ 7 bar
Nominal flow	see FLOW DIAGRAMS on the following pages
Secondary pressure relieving	with relieving (standard) without relieving
Fluid	compressed air

CODING EXAMPLE

M | **0** | **04** | **-** | **R** | **T** | **0** | **2** | **-** | **VS** | **-** | **■** | **-** | **●**

M	SERIES
0	SIZE
04	PORTS: 08 = G1/8 04 = G1/4
R	REGULATOR
T	OPERATING PRESSURE: 0 = 0.5 ÷ 10 bar (standard) 1 = 0.5 ÷ 4 bar 2 = 0.5 ÷ 2 bar 7 = 0.5 ÷ 7 bar T = calibrated * B = locked *
0	DESIGN TYPE: 0 = self relieving 1 = non relieving 5 = relieving with precise setting
2	PRESSURE GAUGE = without pressure gauge (standard) ** the pressure gauges are supplied disassembly mod. M043-P. 1 = with pressure gauge 0-2.5 with working pressure 0.5 ÷ 2 bar 2 = with pressure gauge 0-6 with working pressure 0.5 ÷ 4 bar 3 = with pressure gauge 0-10 with working pressure 0.5 ÷ 7 bar 4 = with pressure gauge 0-12 with working pressure 0.5 ÷ 10 bar
VS	REGULATION TYPE: = without high relief flow (standard) VS = high relief flow
<p>* NOTE: IF THE REGULATOR IS CALIBRATED OR LOCKED, AFTER THE REGULATION TYPE ADD THE INLET PRESSURE "■" AND THE OUTLET PRESSURE "●"</p> <p>INLET PRESSURE: ■ = enter the SUPPLY pressure value</p> <p>OUTLET PRESSURE: ● = enter the OUTLET pressure value for the LOCKED regulator or the maximum value of the ADJUSTABLE pressure for the CALIBRATED regulator</p> <p>Example of a calibrated regulator with Inlet Pressure = 6.3 bar and Outlet Pressure = 4.5 bar Complete part number: M04-RT0-6.3-4.5</p>	

SERIES M PRESSURE MICROREGULATORS

FLOW DIAGRAMS

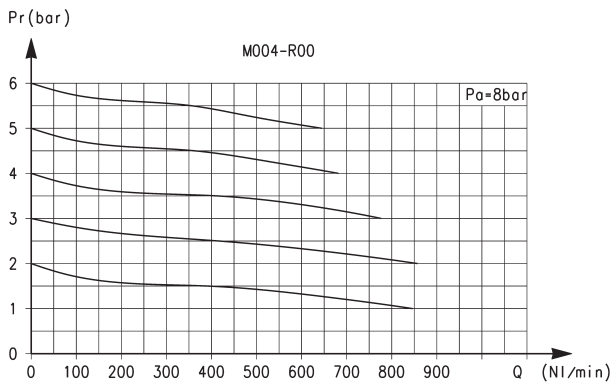

Flow diagram for models: M004-R00
Pa = Inlet pressure (bar)
Pr = Regulated pressure (bar)
Qn = Flow (NL/min)

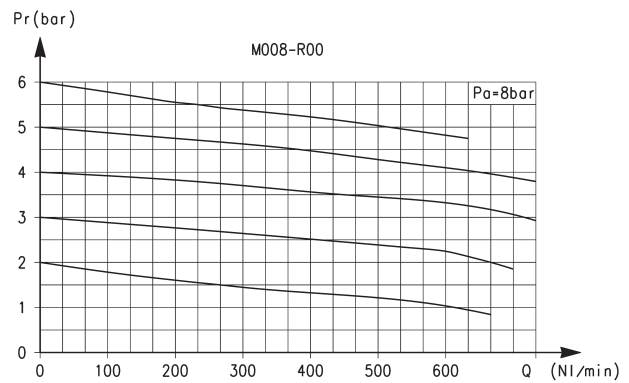

Flow diagram for models: M008-R00
Pa = Inlet pressure (bar)
Pr = Regulated pressure (bar)
Qn = Flow (NL/min)

PNEUMATIC SYMBOLS

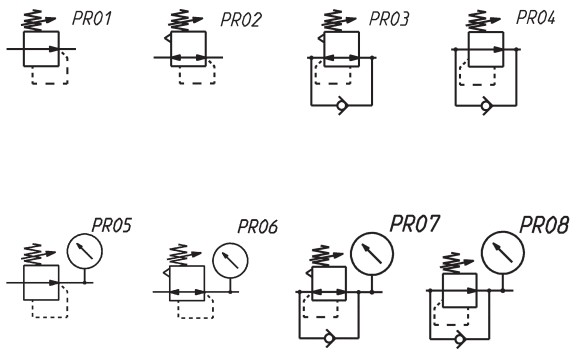

- PR01 = reg. without relieving
- PR02 = reg. with relieving
- PR03 = reg. with relieving and by-pass valve
- PR04 = reg. without relieving with by-pass valve
- PR05 = reg. without relieving with pressure gauge
- PR06 = reg. with relieving and pressure gauge
- PR07 = reg. with relieving, by-pass valve and pressure gauge
- PR08 = reg. without relieving with by-pass valve and pressure gauge

SERIES M PRESSURE MICROREGULATORS

Series M pressure microregulator

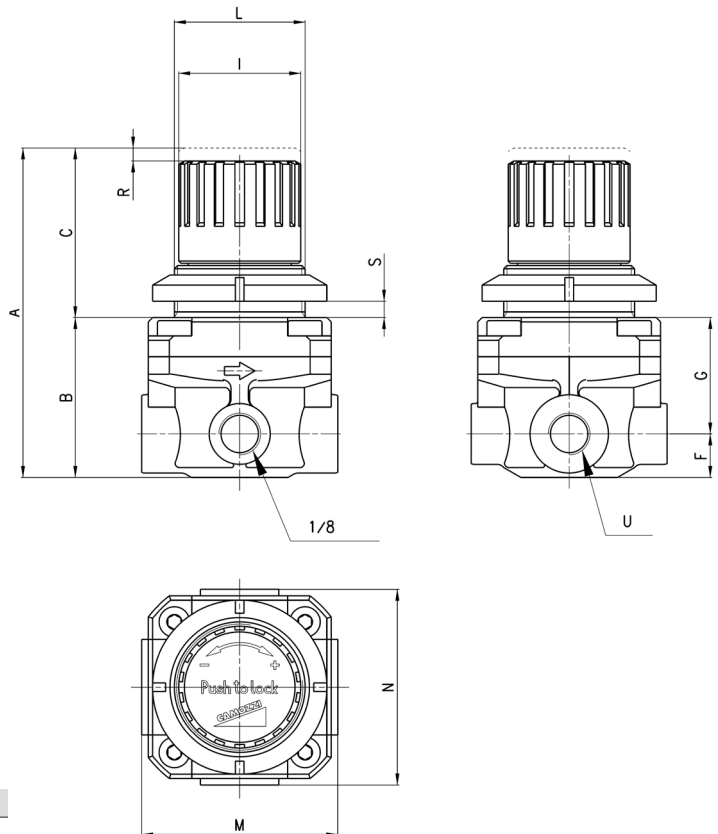

DIMENSIONS										
Mod.	A	B	C	F	G	I	L	M	N	U
M008-R00	76	37	39	10	27	28	M30x1,5	45	45	3 0 ÷ 6 G1/8
M004-R00	76	37	39	10	27	28	M30x1,5	45	45	3 0 ÷ 6 G1/4
M008-R01-E-OX1	76	37	39	10	27	28	M30x1,5	45	45	3 0 ÷ 6 G1/8
M004-R01-E-OX1	76	37	39	10	27	28	M30x1,5	45	45	3 0 ÷ 6 G1/4

Series T pressure microregulators

Ports G1/8 and G1/4



- » Extremely lightweight
- » Compact
- » In-line or console mounting

All models are equipped with a by-pass valve which is useful when a regulator should be inserted between the valve and cylinder (or capacity) without any negative influence on the exhaust.

Series T pressure regulators are available with G1/8 and G1/4 brass connections. A self-relieving piston has been incorporated into the design to allow decreasing adjustments. Non-relieving versions are also available.

GENERAL DATA

Construction	piston
Materials	technopolymer body and piston, stainless steel spring, brass inserts, NBR O-ring and poppet
Ports	G1/8 - G1/4
Weight	g 95
Pressure gauge ports	G1/8
Mounting	in-line or panel mounting (in any position)
Operating temperature	-5°C ÷ 50°C (with the dew point of the fluid lower than 2°C at the min. working temperature)
Inlet pressure	0 ÷ 12 bar
Outlet pressure	0.5 ÷ 10 bar (standard) 0.5 ÷ 2 bar 0.5 ÷ 4 bar 0.5 ÷ 7 bar
Nominal flow	see FLOW DIAGRAMS on the following pages
Secondary pressure relieving	with relieving (standard) without relieving (all regulators are provided with high relief flow VS function)
fluid	compressed air

CODING EXAMPLE

T	1	08	-	R	0	0	2
----------	----------	-----------	----------	----------	----------	----------	----------

T	SERIES						
1	SIZE						
08	PORTS: 08 = G1/8		04 = G1/4				
R	REGULATOR						
0	OPERATING PRESSURE: 0 = 0,5 ÷ 10 1 = 0 ÷ 4		2 = 0 ÷ 2 7 = 0 ÷ 7 (standard)				
0	DESIGN TYPE: 0 = self-relieving; 1 = non relieving						
2	MANOMETERS: ** = without pressure gauge (standard) 1 = with pressure gauge 0-2,5, with working pressure 0÷2 bar 2 = with pressure gauge 0-6, with working pressure 0÷4 bar				3 = with pressure gauge 0-10, with working pressure 0,5÷7 bar 4 = with pressure gauge 0-12, with working pressure 0,5÷10 bar		** the pressure gauges are supplied dismantling manometers mod. M043-P ..

FLOW DIAGRAMS

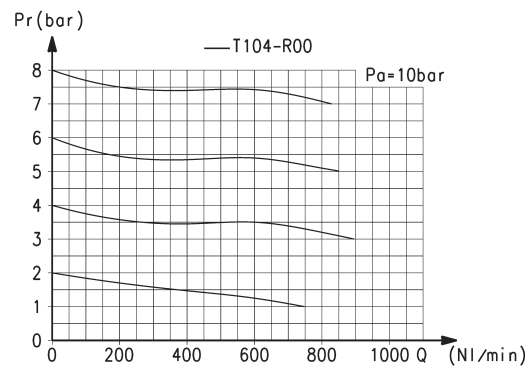
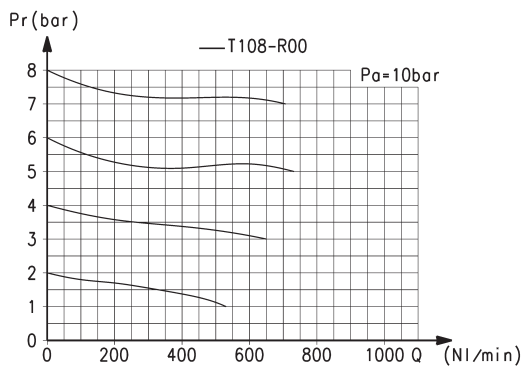

Flow diagram for model: T108-R00
Pa = Inlet pressure (bar)
Pr = Regulated pressure (bar)
Q = Flow (NI/min)

Flow diagram for model: T104-R00
Pa = Inlet pressure (bar)
Pr = Regulated pressure (bar)
Q = Flow (NI/min)

Series T pressure microregulator

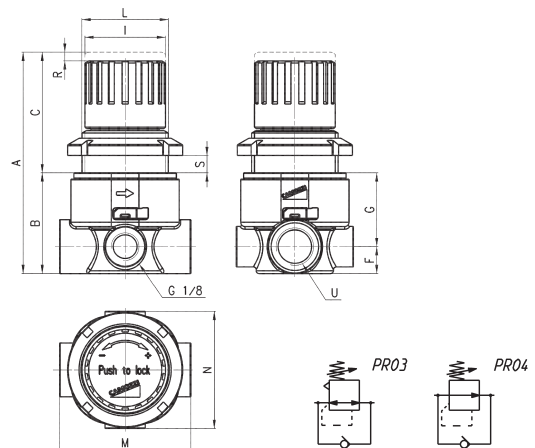

DIMENSIONS												
Mod.	A	B	C	F	G	I	L	M	N	R	S	U
T108-R00	77	35	42	9.5	25.5	28	M30X1.5	46	41	3	7	G1/8
T104-R00	77	35	42	9.5	25.5	28	M30X1.5	46	41	3	7	G1/4

PR03 = regulator with relieving and by-pass valve

PR04 = regulator without relieving and with by-pass valve

ACCESSORIES FOR SERIES M AND T MICROREGULATORS



Mounting bracket
Mod. C114-ST



Mounting bracket
Mod. C114-ST/1



Mounting bracket
Mod. C114-ST/2

ACCESSORIES FOR SERIES M AND T MICROREGULATORS



Systems of rapid connections designed to make mounting easier.

Mounting bracket Mod. C114-ST



The kit is supplied with:
1x zinc-plated steel bracket.

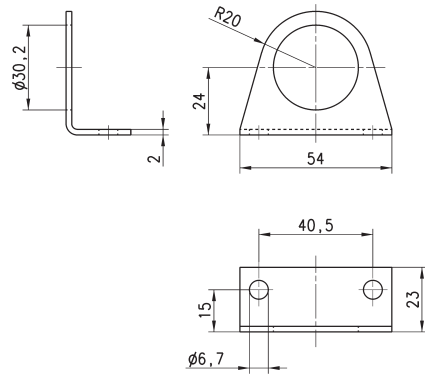

Mod.
C114-ST

Mounting bracket Mod. C114-ST/1



The kit is supplied with 1 zinc-plated steel bracket.

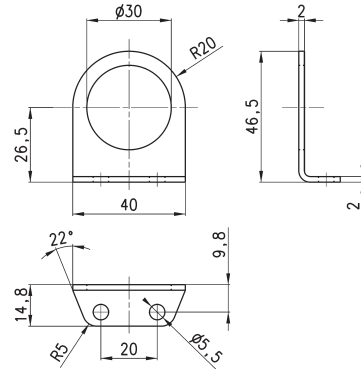

Mod.
C114-ST/1

Mounting bracket Mod. C114-ST/2



The kit is supplied with 1 zinc-plated steel bracket.

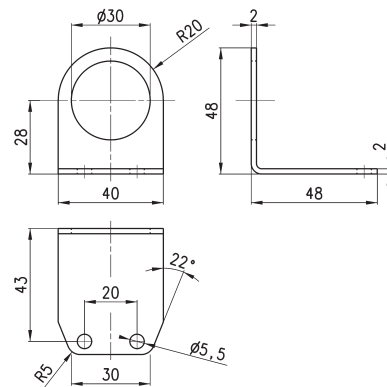

Mod.
C114-ST/2

Series PR precision regulators with manual override

Size 1 ports: G1/4
Size 2 ports: G1/4, G3/8



- » High precision adjustment
- » Multi-diaphragm construction to reach the highest stability
- » Adjustment lock
- » Compact dimensions
- » Removable adjustment knob

The Series PR precision pressure regulators are ideal for applications that require a precise and stable air pressure control. The operating principle using multiple diaphragms allows the Series PR to react to even the smallest pressure variations that may occur during use.

GENERAL DATA

Construction	compact, multi-diaphragm type
Materials	see the following page
Ports	Size 1: G1/4 Size 2: G1/4, G3/8
Mounting	vertical in-line, wall or panel mounting (in any position)
Working temperature	0°C ÷ 50°C
Inlet pressure	0.1 ÷ 12 bar
Outlet pressure	0.05 ÷ 2 bar 0.05 ÷ 4 bar 0.05 ÷ 7 bar 0.05 ÷ 10 bar
Overpressure exhaust	with relieving (standard)
Nominal flow	see FLOW DIAGRAMS on the following pages
Media	filtered and not lubricated compressed air according to DIN ISO 8573-1 Classes 1-3-2
Hysteresis	20mbar
Repeatability	±0.2% FS
Bleed air consumption	≤ 5 l/min

CODING EXAMPLE

PR	1	04	-	M	07
PR	SERIES				
1	SIZE: 1 = size 1 2 = size 2				
04	PORTS: 04 = G1/4 38 = G3/8 (size 2 only)				
M	TYPE OF ADJUSTMENT: M = manual				
07	OPERATING PRESSURE (1 bar = 14,5 psi): 02 = 0.05 ÷ 2 bar 04 = 0.05 ÷ 4 bar 07 = 0.05 ÷ 7 bar 00 = 0.05 ÷ 10 bar				

SERIES PR PRECISION REGULATORS

Series PR precision regulators - materials

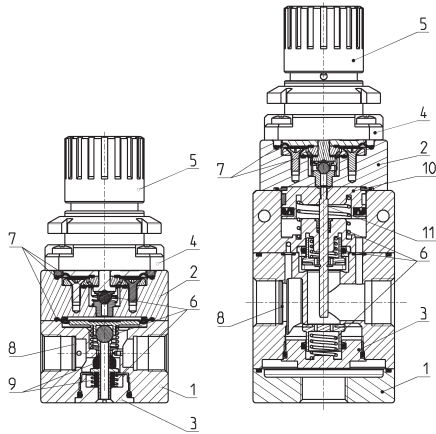

PARTS	MATERIALS
1 = Body	Anodized aluminium
2 = Intermediate body	Aluminium
3 = Valve holder plug	Brass
4 = Bell	Polyamide
5 = Regulator knob	Polyamide
6 = Springs	Stainless steel
7 = Diaphragms	NBR
8 = Filters	Stainless steel
9 = Seals	NBR
10 = Piston	Aluminium
11 = Rod	Stainless steel
O-ring	NBR

Series PR precision regulators - size 1



* to complete the code, add the OPERATING PRESSURE (see the CODING EXAMPLE)

PR02 = Regulator with relieving

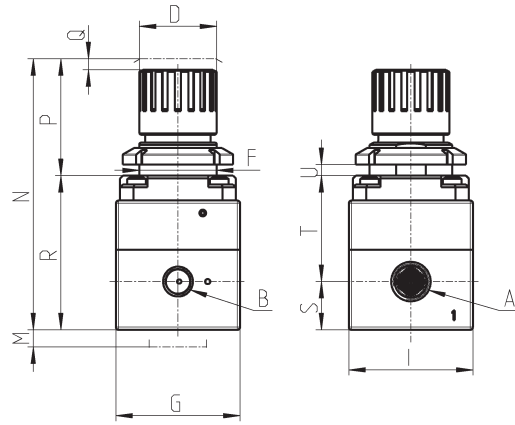
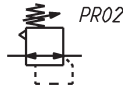

DIMENSIONS																
Mod.	A	B	D	F	G	I	M	N	P	Q	R	S	T	U	Weight (Kg)	
PR104-M*	G1/4	G1/8	28	30	45	45	25	96	40	2	56	17.5	38.5	0-6	0.35	

Series PR precision regulators - size 2



* to complete the code, add the OPERATING PRESSURE (see the CODING EXAMPLE)

PR02 = Regulator with relieving

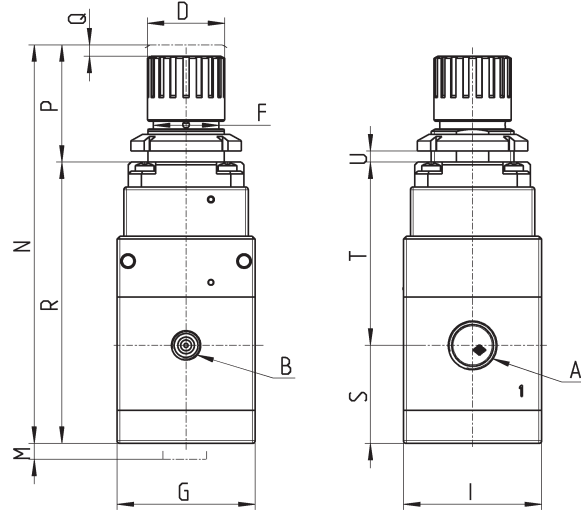

DIMENSIONS																
Mod.	A	B	D	F	G	I	M	N	P	Q	R	S	T	U	Weight (Kg)	
PR204-M*	G1/4	G1/8	28	30	50	50	25	140	40	2	101.8	35.5	66.3	0-6	0.645	
PR238-M*	G3/8	G1/8	28	30	50	50	25	140	40	2	101.8	35.5	66.3	0-6	0.645	

FLOW DIAGRAMS Mod. PR104-M00

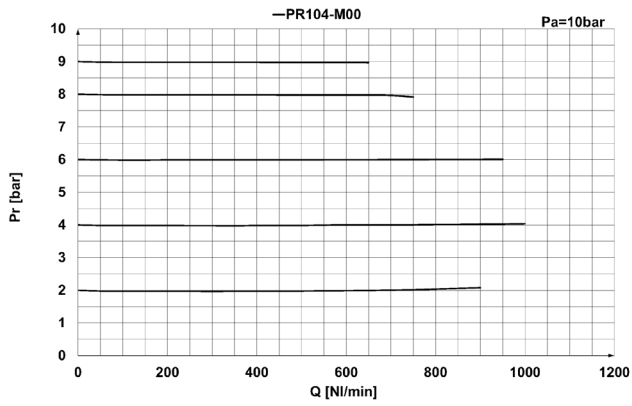

Pr = Regulated pressure (bar)
 Q = Flow (NL/min)
 Pa = Inlet pressure (bar)

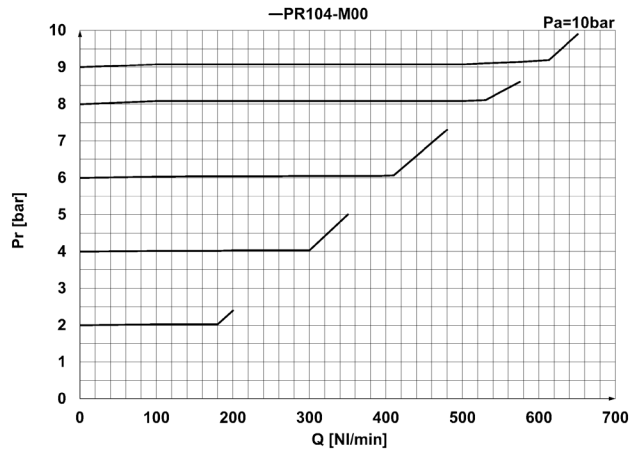

EXHAUST FLOW
 Pr = Regulated pressure (bar)
 Q = Flow (NL/min)
 Pa = Inlet pressure (bar)

FLOW DIAGRAMS Mod. PR104-M07

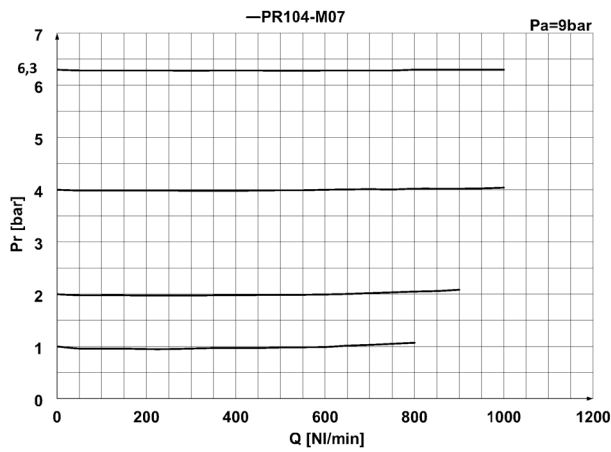

Pr = Regulated pressure (bar)
 Q = Flow (NL/min)
 Pa = Inlet pressure (bar)

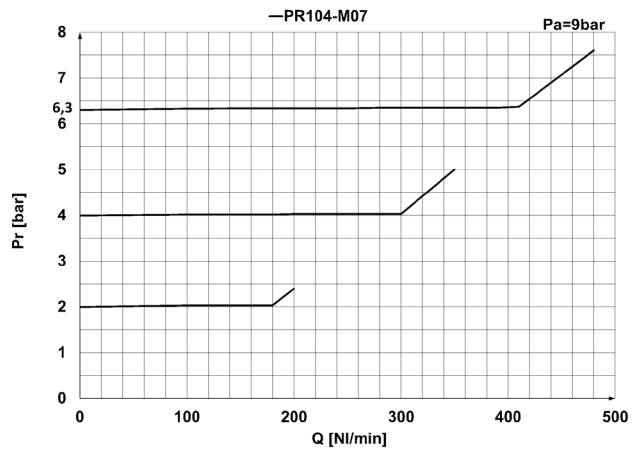

EXHAUST FLOW
 Pr = Regulated pressure (bar)
 Q = Flow (NL/min)
 Pa = Inlet pressure (bar)

FLOW DIAGRAMS Mod. PR104-M04

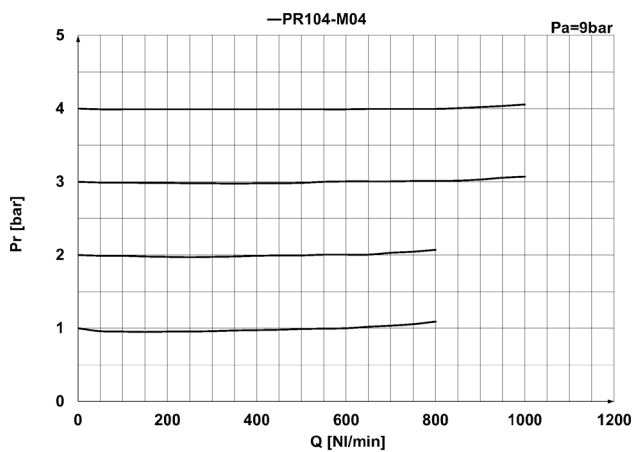

Pr = Regulated pressure (bar)
 Q = Flow (NL/min)
 Pa = Inlet pressure (bar)

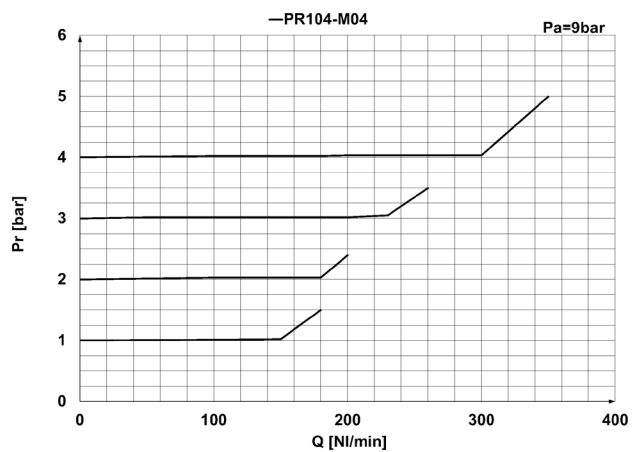

EXHAUST FLOW
 Pr = Regulated pressure (bar)
 Q = Flow (NL/min)
 Pa = Inlet pressure (bar)

FLOW DIAGRAMS Mod. PR104-M02

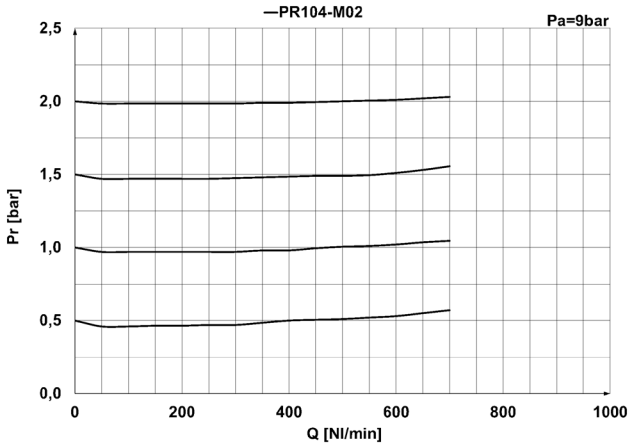

Pr = Regulated pressure (bar)
Q = Flow (NL/min)
Pa = Inlet pressure (bar)

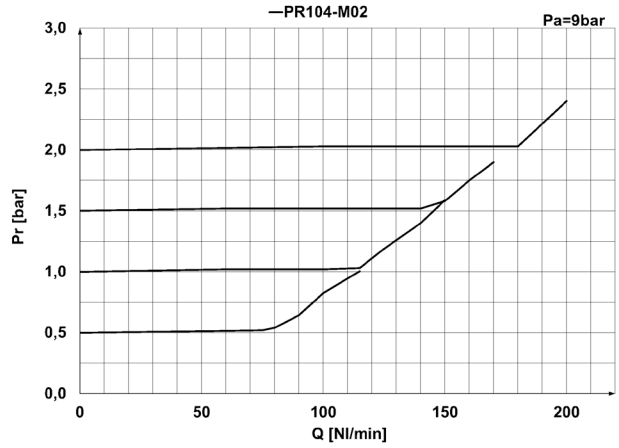

EXHAUST FLOW
Pr = Regulated pressure (bar)
Q = Flow (NL/min)
Pa = Inlet pressure (bar)

FLOW DIAGRAMS Mod. PR204-M00

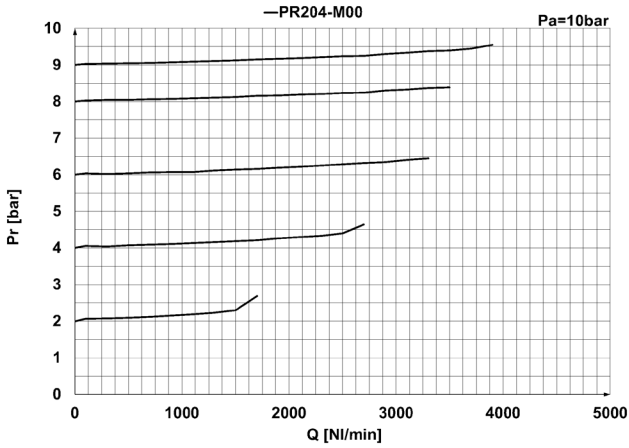

Pr = Regulated pressure (bar)
Q = Flow (NL/min)
Pa = Inlet pressure (bar)

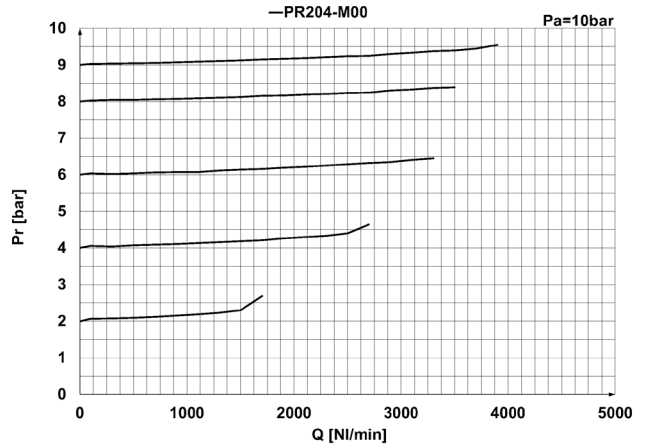

EXHAUST FLOW
Pr = Regulated pressure (bar)
Q = Flow (NL/min)
Pa = Inlet pressure (bar)

FLOW DIAGRAMS Mod. PR204-M07

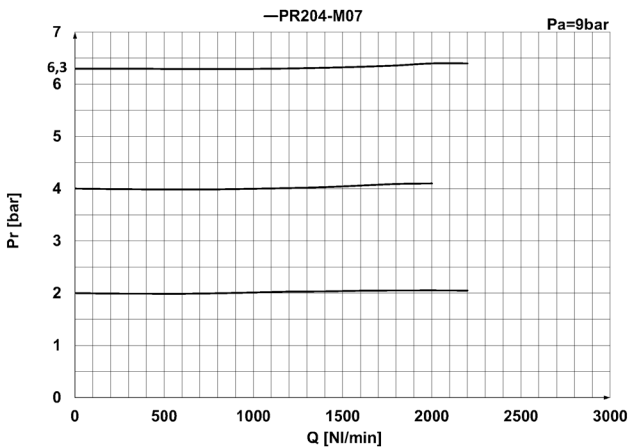

Pr = Regulated pressure (bar)
Q = Flow (NL/min)
Pa = Inlet pressure (bar)

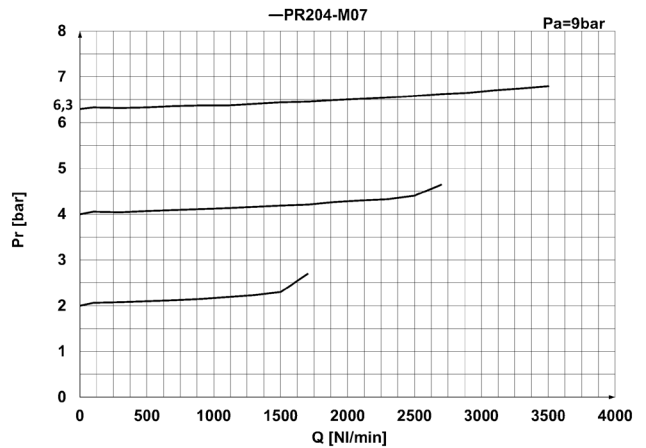

EXHAUST FLOW
Pr = Regulated pressure (bar)
Q = Flow (NL/min)
Pa = Inlet pressure (bar)

FLOW DIAGRAMS Mod. PR204-M04

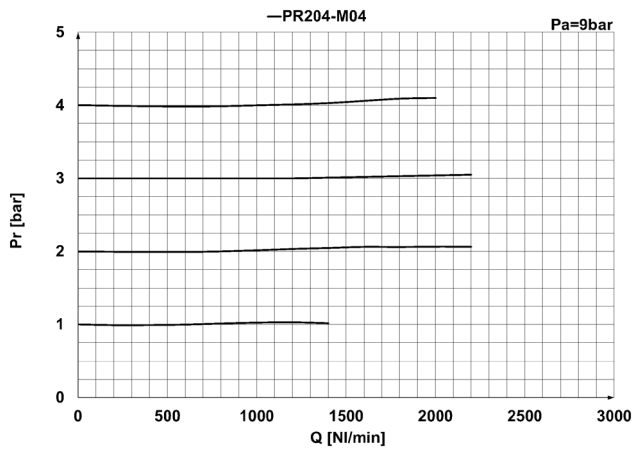

Pr = Regulated pressure (bar)
 Q = Flow (NL/min)
 Pa = Inlet pressure (bar)

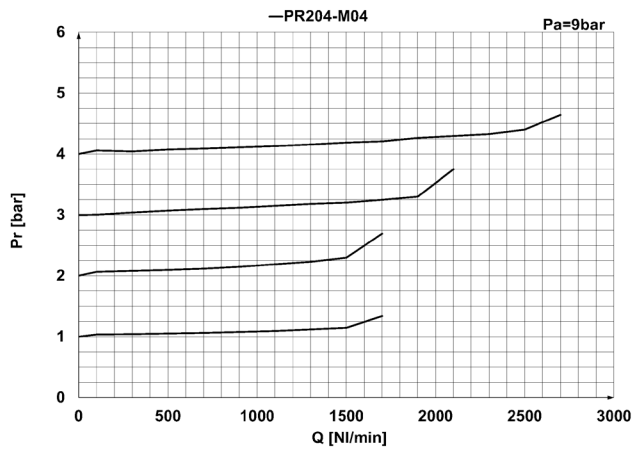

EXHAUST FLOW
 Pr = Regulated pressure (bar)
 Q = Flow (NL/min)
 Pa = Inlet pressure (bar)

FLOW DIAGRAMS Mod. PR204-M02

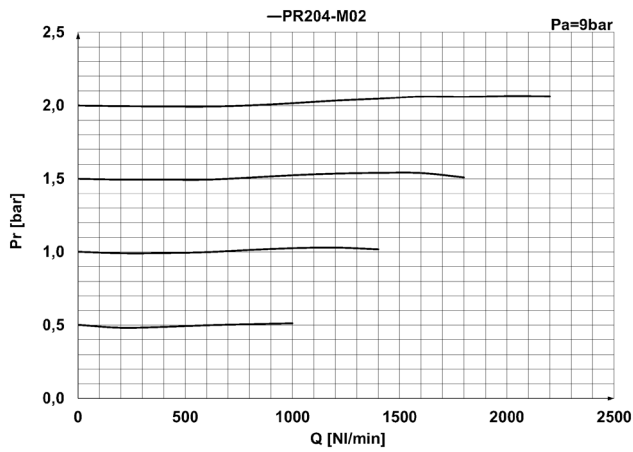

Pr = Regulated pressure (bar)
 Q = Flow (NL/min)
 Pa = Inlet pressure (bar)

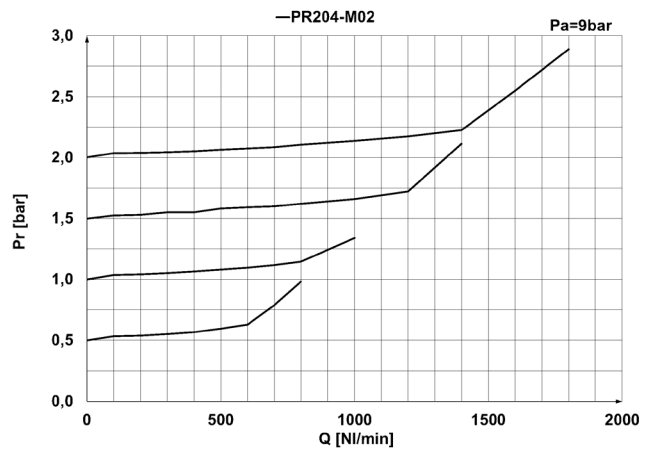

EXHAUST FLOW
 Pr = Regulated pressure (bar)
 Q = Flow (NL/min)
 Pa = Inlet pressure (bar)

FLOW DIAGRAMS Mod. PR238-M00

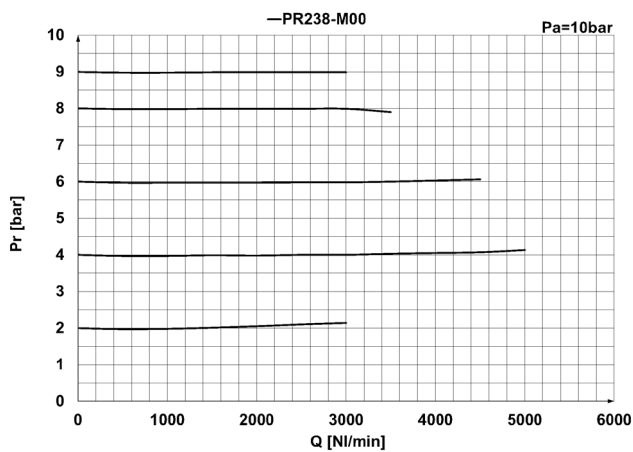

Pr = Regulated pressure (bar)
 Q = Flow (NL/min)
 Pa = Inlet pressure (bar)

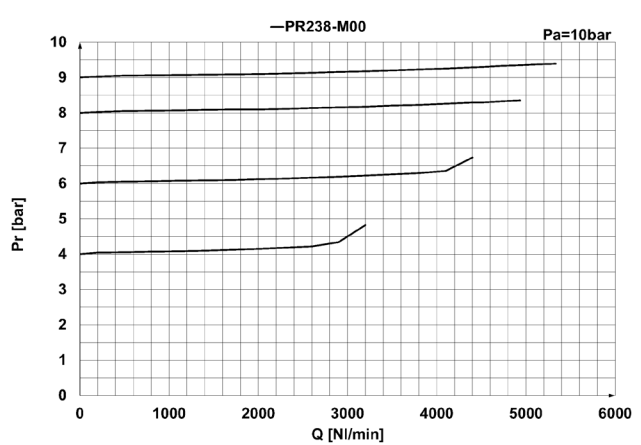

EXHAUST FLOW
 Pr = Regulated pressure (bar)
 Q = Flow (NL/min)
 Pa = Inlet pressure (bar)

FLOW DIAGRAMS Mod. PR238-M07

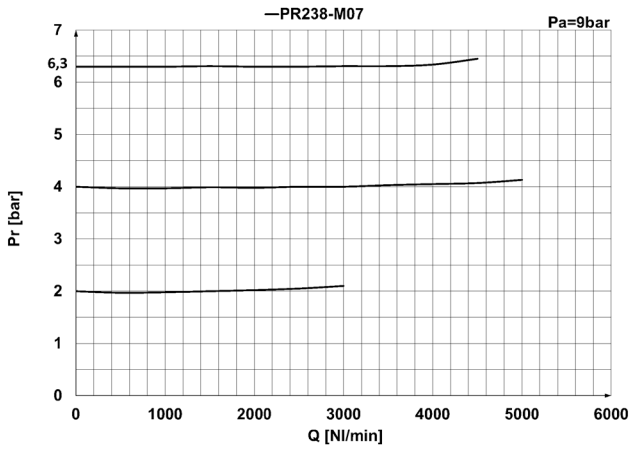

Pr = Regulated pressure (bar)
Q = Flow (NL/min)
Pa = Inlet pressure (bar)

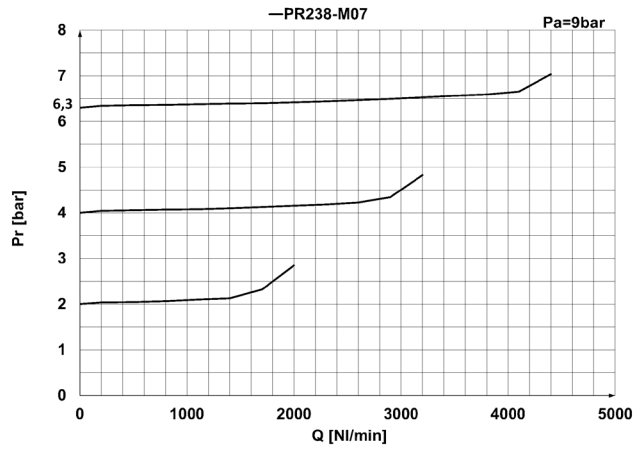

EXHAUST FLOW
Pr = Regulated pressure (bar)
Q = Flow (NL/min)
Pa = Inlet pressure (bar)

FLOW DIAGRAMS Mod. PR238-M04

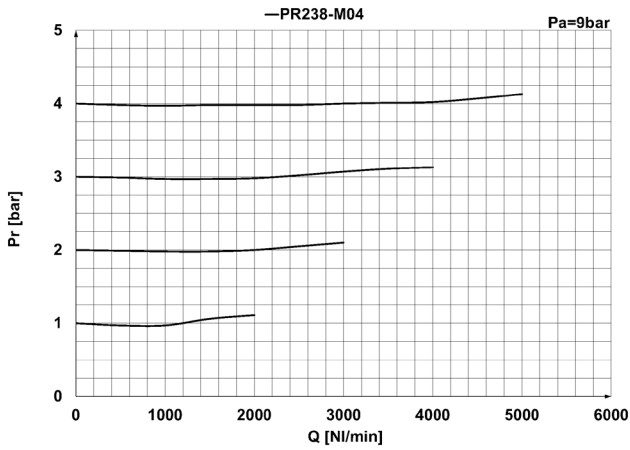

Pr = Regulated pressure (bar)
Q = Flow (NL/min)
Pa = Inlet pressure (bar)

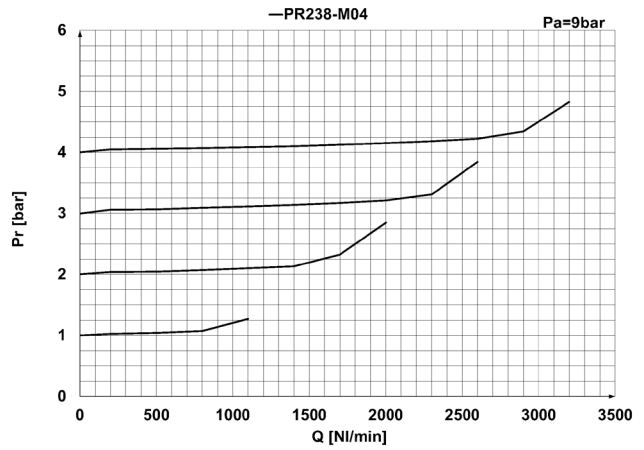

EXHAUST FLOW
Pr = Regulated pressure (bar)
Q = Flow (NL/min)
Pa = Inlet pressure (bar)

FLOW DIAGRAMS Mod. PR238-M02

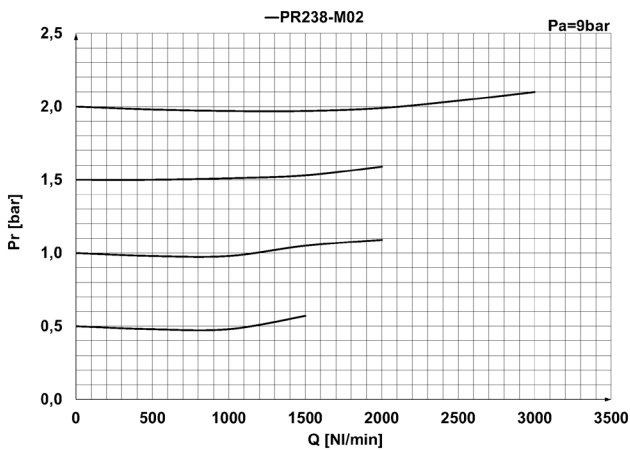

Pr = Regulated pressure (bar)
Q = Flow (NL/min)
Pa = Inlet pressure (bar)

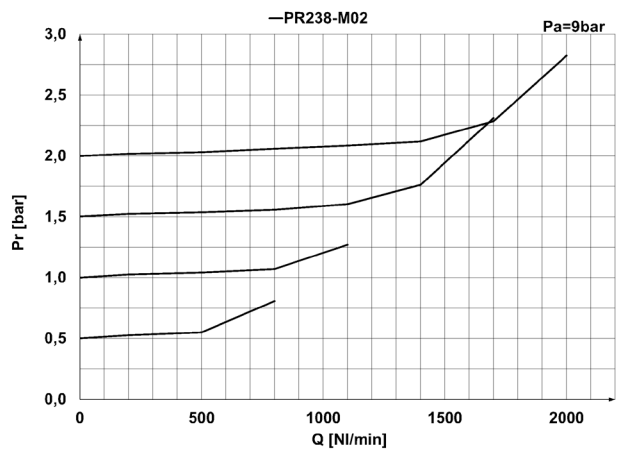

EXHAUST FLOW
Pr = Regulated pressure (bar)
Q = Flow (NL/min)
Pa = Inlet pressure (bar)

Pressure switches, Transducers, Pressure indicators

Series PM: adjustable-diaphragm pressure switches, with setting visual scale, with exchange contacts

Series TRP: electro-pneumatic transducers

Series 2950: pressure indicators, ports M5



A regulating screw, which can be adjusted using a small screwdriver, allows the switch to be set to the required pressure. The calibrated diaphragm enables an electrical signal to be generated or inhibited depending on the pressure set.

Series PM diaphragm pressure switches are available with NC (normally closed) contacts and with NO (normally open) contacts.

Series PM681 pressure switches with setting visual scale comply with EN60730 standards and are suitable for signaling pressure through a normally closed Reed contact.

GENERAL DATA

Construction	with adjustable diaphragm
Ports	R1/8, G1/4 (Serie PM) tube 4/2 (Series TRP) M5 (Series 2950)
Mounting	using thread in body
Max. nr. of pulses per 1'	200
Pressure	1 ÷ 10 bar max.
Operating temperature	-5°C ÷ +60°C
Max. power	100 VA
Voltage	220 V
Isolation voltage	1500 V
Max current	0.5 A
Pressure switches protection class	IP40 (Mod. PM681-1, PM681-3) IP54 (Mod. PM11-NC, PM11-NA) IP65 (Mod. PM11-SC)

Series PM adjustable-diaphragm pressure switches



Supplied with a rubber cap providing protection class IP54.

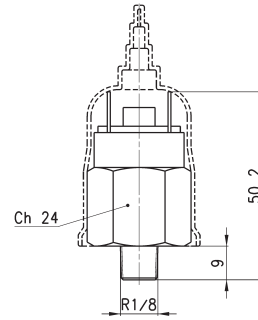

Mod.	Function	Max Voltage	Max Power	Service Type	Insulation voltage	Symbol
PM11-NC	NC = normally closed	48 V AC DC	24 VA	Heavy	500 V	PMNC
PM11-NA	NA = normally open	48 V AC DC	24 VA	Heavy	500 V	PMNO
PM11-NC-OX1	NC = normally closed	48 V AC DC	24 VA	Heavy	500 V	PMNC
PM11-NCEX	NC = normally closed	48 V AC DC	24 VA	Heavy	500 V	PMNC
PM11-NA-OX1	NA = normally open	48 V AC DC	24 VA	Heavy	500 V	PMNO
PM11-NAEX	NA = normally open	48 V AC DC	24 VA	Heavy	500 V	PMNO

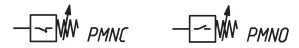

PMNC = normally closed
PMNO = normally open

Series PM681-... - pressure switches with setting visual scale



In compliance with EN60730 standard
Protection class IP40
Electric connection: PVC cable 2 x 0.22 mm
Electric contact: Reed SPST NO
Body in anodized aluminium and threaded fitting in brass
Hysteresis: 0.8 bar max

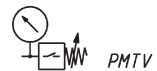
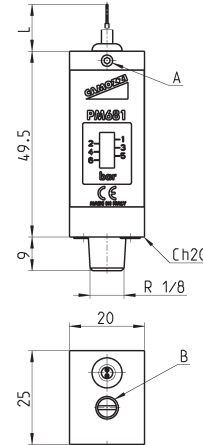

A = SETTING GRAIN LOCKING

B = ADJUSTMENT SCREW

Mod.	L	Max switch voltage	Max switch current	Max switch capacity	Max fluid temperature	Max pressure	Setting range	Weight
PM681-1	1 m	48 V	0.5 A	10 W	60°C	20 bar	1 ÷ 6 bar	95 g
PM681-3	3 m	48 V	0.5 A	10 W	60°C	20 bar	1 ÷ 6 bar	95 g

Pressure switch with exchange contacts Mod. PM11-SC



Protection class IP65
(with connector Mod. 124-830)

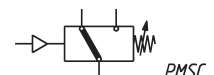
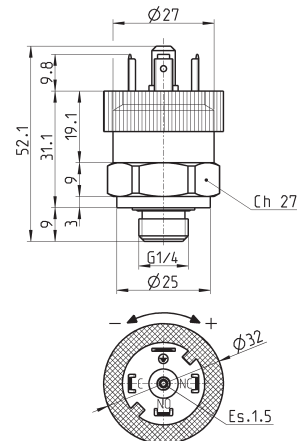

(*) SC = exchange contacts

DIMENSIONS							
Mod.	Function	Max Voltage	Operating Temperature	Actuation time	Setting range	Max Hysteresis	
PM11-SC	SC (*)	250V AC - 30V DC	-25°C +85°C	> 0,1 ms	2 ÷ 10 bar	0.8 bar	
PM11-SCEX	SC (*)	250V AC - 30V DC	-25°C +85°C	> 0,1 ms	2 ÷ 10 bar	0.8 bar	
PM11-SCUL	SC (*)	250V AC - 30V DC	-25°C +85°C	> 0,1 ms	2 ÷ 10 bar	0.8 bar	

Electro-pneumatic transducer Series TRP



Series TRP electro-pneumatic transducer is particularly suitable to convert a pneumatic signal into an electrical signal. The contacts are NC (normally closed) or NO (normally open), thus making it possible to generate or eliminate current when the pneumatic signal is present. Minimum operating pressure 2,5 bar.

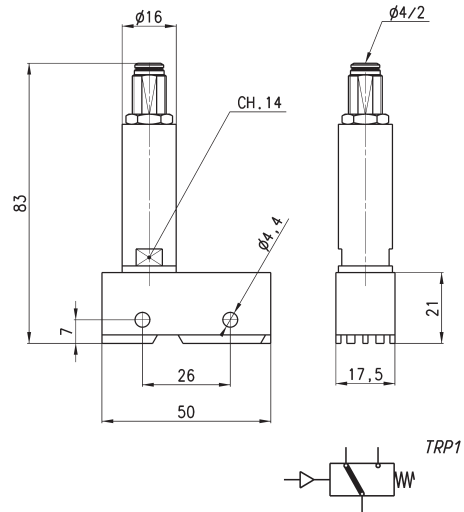

Mod.	TRP-8
------	-------

Pressure indicators Series 2950



The pressure indicator Mod. 2950-M5 is passive element (no spring, red colour). It is useful for detecting pressure manually without having to remove the connections.

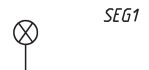
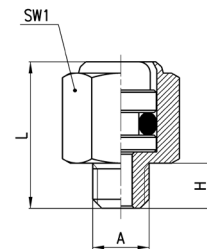

DIMENSIONS				
Mod.	A	H	L	SW1
2950 M5	M5	4	13.5	8

3-pole connector Mod. 124-830 for pressure switch Mod. PM11-SC

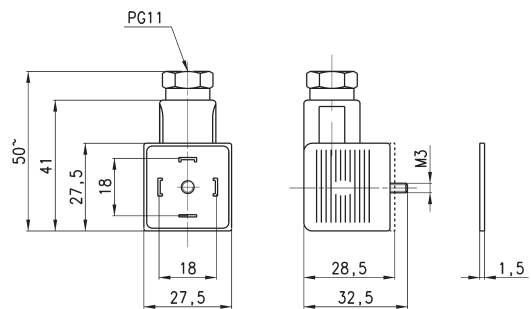

Mod.	description	colour	working voltage	cable gland	tightening torque
124-830	three-pole connector without electronics	black	-	PG9/PG11	0.5 Nm
124-830EX	three-pole ATEX connector without electronics	black	-	PG9/PG11	0.5 Nm

New

Series SWMN and SWMS compact electronic pressure switches / vacuum switches

Ports: G1/8, M5 thread or Ø 4, 6 mm plug-in tube
Measuring range: 0 ÷ -1 bar, 0 ÷ 1 bar with analog output,
0 ÷ -1 bar, 0 ÷ 6 bar with digital PNP output



SERIES SWMN/SWMS PRESSURE/VACUUM SWITCHES

The Series SWMN and SWMS vacuum/pressure switches can be installed directly at the measuring point or pressure/vacuum determination point in handling systems, thanks to its highly compact dimensions.

Its reduced weight (only 50 grams with a 2 meter cable) and robust construction allow its installation on applications with high accelerations.

The four types of connection enable a high flexibility and an easy installation inside machines or pneumatic cabinets.

- » Minimum dimensions
- » Reduced weight
- » Available with analog or digital output
- » High measuring precision

GENERAL DATA

Operating pressure range	-1 ÷ 0 bar; 0 ÷ 10 bar; -1 ÷ 10 bar
Medium	filtered air and inert gases
Supply voltage	12 ÷ 24 V DC
Maximum load	80 mA (SWMN-AP/AV/PN/PP) 40 mA (SWMS-NO/NC)
Voltage drop	0.8 V (SWMN-AP/AV/PN/PP) 5 V (SWMS-NO/NC)
Short circuit protection	models SWMN-AP/AV/PN/PP
Response time	about 1 msec
Repeatability	±1% F.S.
Hysteresis	3% F.S. (SWMN-AP/AV/PN/PP) 4% F.S. (SWMS-NO/NC)
Protection class	IP40
Operating temperature	0 ÷ 50°C
Connection cable	oil resistant, 2 or 3-wire cable (according to the model), outer sheath Ø 2.6 mm

CODING EXAMPLE

SWMN	-	AP	-	T	-	2
SWMN	SERIES SWMN SWMS					
AP	OUTPUT SIGNAL (SWMN) AV = analog output signal - vacuum AP = analog output signal - pressure PN = PNP output - vacuum PP = PNP output - pressure			OUTPUT SIGNAL (SWMS) NO = normally open NC = normally closed		
T	TYPE OF CONNECTION T = Ø 6 tube U = Ø 4 tube (only for SWMN) G = G1/8 thread M = M5 thread					
2	ELECTRIC CONNECTION 2 = cable of 2 meters M = M8 3 pin connector					

TECHNICAL DATA

Mod.	SWMN-PN	SWMN-PP	SWMN-AV	SWMN-AP	SWMS-NO	SWMS-NC
Medium	air, non-corrosive and non-flammable gases	air, non-corrosive and non-flammable gases	air, non-corrosive and non-flammable gases	air, non-corrosive and non-flammable gases	air, non-corrosive and non-flammable gases	air, non-corrosive and non-flammable gases
Operating pressure range	-1 ÷ 0 bar	0 ÷ 6 bar	-1 ÷ 0 bar	0 ÷ 10 bar	-1 ÷ 6 bar	-1 ÷ 6 bar
Precision	±1% operating range	±1% operating range	±1% operating range	±1% operating range	±1% operating range	±1% operating range
Max overpressure	6 bar	15 bar	2 bar	15 bar	15 bar	15 bar
Output signal	PNP	PNP	1 ÷ 5 V ≤ ±1% F.S. Linearity ≤ ±0.5% F.S.	1 ÷ 5 V ≤ ±1% F.S. Linearity ≤ ±0.5% F.S.	NO	NC
Hysteresis	3% F.S.	3% F.S.	-	-	≤4% F.S.	≤4% F.S.
Maximum output current	80 mA	80 mA	-	-	5 ÷ 40 mA	5 ÷ 40 mA
Voltage	10.8 ÷ 30 V DC	10.8 ÷ 30 V DC	12 ÷ 24 V DC	12 ÷ 24 V DC	12 ÷ 24 V DC	12 ÷ 24 V DC
Voltage drop	≤0.8 V	≤0.8 V	≤0.8 V	≤0.8 V	≤5 V	≤5 V
Protection class	IP40	IP40	IP40	IP40	IP40	IP40
Short circuit protection	yes	yes	yes	yes	-	-
Temperature effect (temperature range between 0 and 50°C)	±3% F.S.	±3% F.S.	±2% F.S.	±2% F.S.	±3% F.S.	±3% F.S.
Response time	1 ms	1 ms	-	-	1 ms	1 ms
Environmental temperature	0 ÷ 60°C	0 ÷ 60°C	0 ÷ 50°C	0 ÷ 50°C	0 ÷ 60°C	0 ÷ 60°C
Repeatability	≤±1% F.S.	≤±1% F.S.	-	-	≤±1% F.S.	≤±1% F.S.
Indication	LED	LED	-	-	LED	LED
Electric connection	cable or M8 3 pin female connector	cable or M8 3 pin female connector	cable or M8 3 pin female connector	cable or M8 3 pin female connector	cable or M8 3 pin female connector	cable or M8 3 pin female connector
Cable (oil resistant)	2 wires 0.18 mm ² , Ø 2.6 mm	2 wires 0.18 mm ² , Ø 2.6 mm	2 wires 0.18 mm ² , Ø 2.6 mm	2 wires 0.18 mm ² , Ø 2.6 mm	2 wires 0.18 mm ² , Ø 2.6 mm	2 wires 0.18 mm ² , Ø 2.6 mm
Weight (with 3-meter cable)	50 g	50 g	50 g	50 g	50 g	50 g

CONNECTION CIRCUIT

SWMN-PN / SWMN-PP

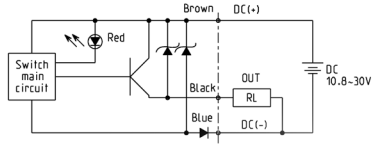

SWMN-AV / SWMN-AP

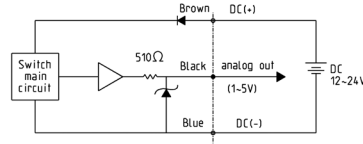

SWMS-NO / SWMS-NC

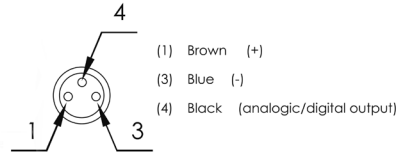
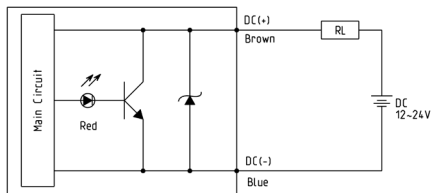

PRESSURE ADJUSTMENT

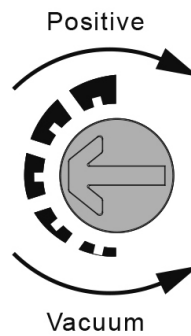
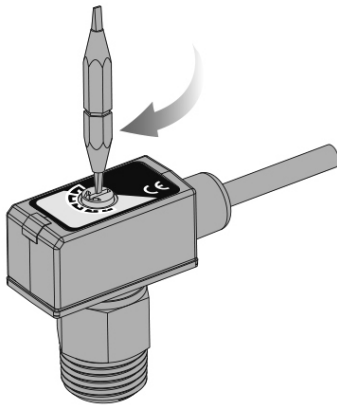

For models SWMS-NO and SWMS-NC

Rotate clockwise to increase the opening pressure of the contact for NC versions and the closing for NO versions.

For models SWMN-PN and SWMN-PP

Rotate clockwise to increase the opening pressure of the contact for NC versions and the closing for NO versions.

Vacuum/pressure switches Mod. SWMN-AV/AP/PN/PP

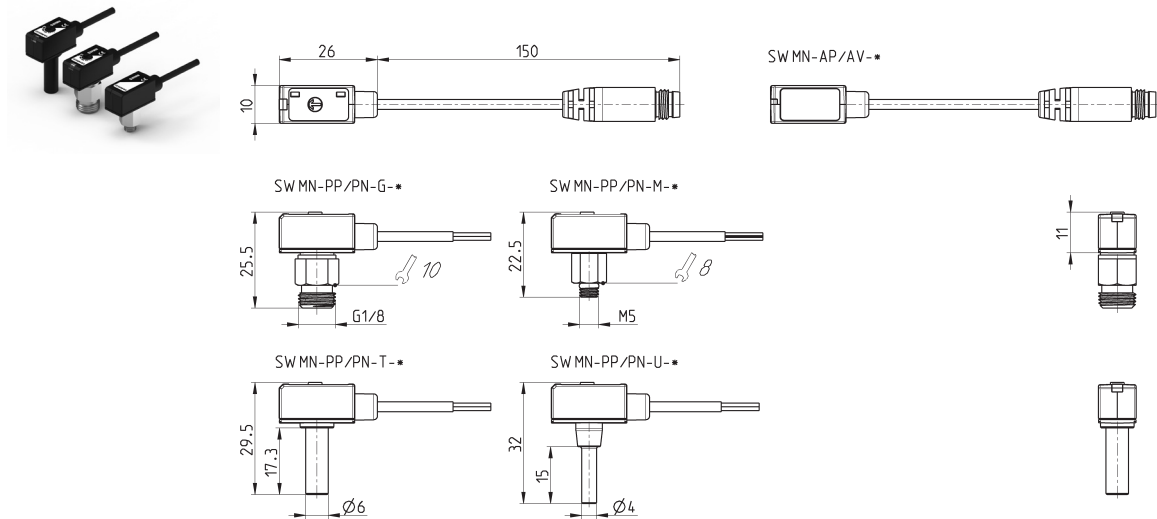

Mod.	Output signal	Type of connection	Electric connection
SWMN-AV-T-2	analog output signal - vacuum	Ø 6 tube	cable of 2 meters
SWMN-AV-M-2	analog output signal - vacuum	M5 thread	cable of 2 meters
SWMN-AV-U-2	analog output signal - vacuum	Ø 4 tube	cable of 2 meters
SWMN-AV-G-2	analog output signal - vacuum	G1/8 thread	cable of 2 meters
SWMN-AV-T-M	analog output signal - vacuum	Ø 6 tube	M8 3 pin connector
SWMN-AV-M-M	analog output signal - vacuum	M5 thread	M8 3 pin connector
SWMN-AV-U-M	analog output signal - vacuum	Ø 4 tube	M8 3 pin connector
SWMN-AV-G-M	analog output signal - vacuum	G1/8 thread	M8 3 pin connector
SWMN-AP-T-2	analog output signal - pressure	Ø 6 tube	cable of 2 meters
SWMN-AP-M-2	analog output signal - pressure	M5 thread	cable of 2 meters
SWMN-AP-U-2	analog output signal - pressure	Ø 4 tube	cable of 2 meters
SWMN-AP-G-2	analog output signal - pressure	G1/8 thread	cable of 2 meters
SWMN-AP-T-M	analog output signal - pressure	Ø 6 tube	M8 3 pin connector
SWMN-AP-M-M	analog output signal - pressure	M5 thread	M8 3 pin connector
SWMN-AP-U-M	analog output signal - pressure	Ø 4 tube	M8 3 pin connector
SWMN-AP-G-M	analog output signal - pressure	G1/8 thread	M8 3 pin connector
SWMN-PN-T-2	PNP output - vacuum	Ø 6 tube	cable of 2 meters
SWMN-PN-M-2	PNP output - vacuum	M5 thread	cable of 2 meters
SWMN-PN-U-2	PNP output - vacuum	Ø 4 tube	cable of 2 meters
SWMN-PN-G-2	PNP output - vacuum	G1/8 thread	cable of 2 meters
SWMN-PN-T-M	PNP output - vacuum	Ø 6 tube	M8 3 pin connector
SWMN-PN-M-M	PNP output - vacuum	M5 thread	M8 3 pin connector
SWMN-PN-U-M	PNP output - vacuum	Ø 4 tube	M8 3 pin connector
SWMN-PN-G-M	PNP output - vacuum	G1/8 thread	M8 3 pin connector
SWMN-PP-T-2	PNP output - pressure	Ø 6 tube	cable of 2 meters
SWMN-PP-M-2	PNP output - pressure	M5 thread	cable of 2 meters
SWMN-PP-U-2	PNP output - pressure	Ø 4 tube	cable of 2 meters
SWMN-PP-G-2	PNP output - pressure	G1/8 thread	cable of 2 meters
SWMN-PP-T-M	PNP output - pressure	Ø 6 tube	M8 3 pin connector
SWMN-PP-M-M	PNP output - pressure	M5 thread	M8 3 pin connector
SWMN-PP-U-M	PNP output - pressure	Ø 4 tube	M8 3 pin connector
SWMN-PP-G-M	PNP output - pressure	G1/8 thread	M8 3 pin connector

Vacuum/pressure switches Mod. SWMS-NO/NC

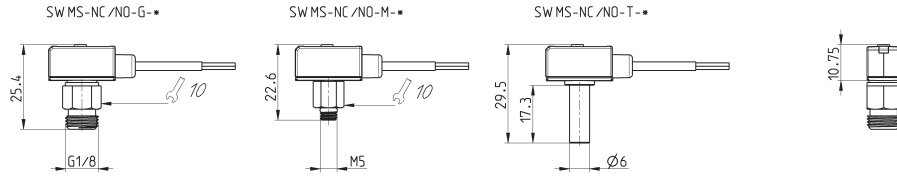
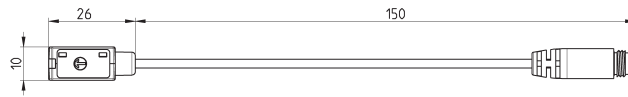

Mod.	Output signal	Type of connection	Electrical connection	Operating pressure range	Range of adjustment
SWMS-NO-T-2	NO	Ø 6 tube	cable of 2 meters	-1 ÷ 15 bar	-1 ÷ 6 bar
SWMS-NO-M-2	NO	M5 thread	cable of 2 meters	-1 ÷ 15 bar	-1 ÷ 6 bar
SWMS-NO-G-2	NO	G1/8 thread	cable of 2 meters	-1 ÷ 15 bar	-1 ÷ 6 bar
SWMS-NO-T-M	NO	Ø 6 tube	M8 3 pin connector	-1 ÷ 15 bar	-1 ÷ 6 bar
SWMS-NO-M-M	NO	M5 thread	M8 3 pin connector	-1 ÷ 15 bar	-1 ÷ 6 bar
SWMS-NO-G-M	NO	G1/8 thread	M8 3 pin connector	-1 ÷ 15 bar	-1 ÷ 6 bar
SWMS-NC-T-2	NC	Ø 6 tube	cable of 2 meters	-1 ÷ 15 bar	-1 ÷ 6 bar
SWMS-NC-M-2	NC	M5 thread	cable of 2 meters	-1 ÷ 15 bar	-1 ÷ 6 bar
SWMS-NC-G-2	NC	G1/8 thread	cable of 2 meters	-1 ÷ 15 bar	-1 ÷ 6 bar
SWMS-NC-T-M	NC	Ø 6 tube	M8 3 pin connector	-1 ÷ 15 bar	-1 ÷ 6 bar
SWMS-NC-M-M	NC	M5 thread	M8 3 pin connector	-1 ÷ 15 bar	-1 ÷ 6 bar
SWMS-NC-G-M	NC	G1/8 thread	M8 3 pin connector	-1 ÷ 15 bar	-1 ÷ 6 bar

SERIES SWMN/SWMS PRESSURE/VACUUM SWITCHES

Series SWDN electronic vacuum/pressure switches

With digital display
High precision, easy to use



- » Compact and lightweight
- » Digital indicator: precision electronic insertion with two separated switch outputs
- » Switching point and hysteresis can be programmed with a membrane keypad.

APPLICATIONS:

- electronic vacuum/pressure switch for safety monitoring, optimization of cycle times or energy saving devices;
- it can be installed directly on the gripping point of a handling system;
- setting of the limit vacuum value and continuous vacuum control;
- perfectly suitable for customer needs.

ELECTRIC CONNECTION:

the device is available with hardwired cable of 2 meters or can be supplied with M8 connector. Accessories and extensions have to be ordered separately. Codes can be found at the end of this section.

GENERAL DATA

Type of pressure/vacuum switch	electronic with polycarbonate housing
Port	with external thread G1/8 and internal thread M5
Display	3 digit display with membrane keypad for the values set up
LED	integrated LED indicators for switching state
Electric connection	with M8 4-pole connector or pre-wired cable of 2 meters

CODING EXAMPLE

SWDN	-	V01	-	P3	-	2
-------------	----------	------------	----------	-----------	----------	----------

SWDN	SERIES
V01	SET PRESSURE RANGE: V01 = from -1 bar to 1 bar P10 = from 0 bar to 10 bar
P3	TYPE OF ELECTRIC CONNECTION: P3 = 2 PNP outputs + 1 analog output 1 - 5 V DC (this version is available with 5-pole cable only) P4 = 2 PNP outputs
2	ELECTRIC CONNECTION: 2 = cable of 2 meters M = M8 4 pin connector

SERIES SWDN ELECTRONIC VACUUM/PRESSURE SWITCHES

Vacuum/Pressure switch Series SWDN



- 1 = brown (+)
- 2 = white (OUT 2)
- 3 = blue (-)
- 4 = black (OUT 1)
- Analogic output = orange

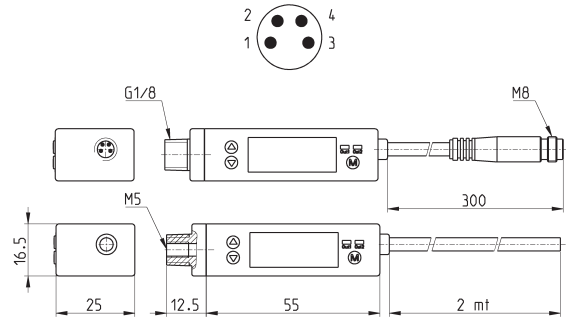

Mod.
SWDN-V01-P3-2
SWDN-V01-P4-2
SWDN-V01-P4-M
SWDN-P10-P3-2
SWDN-P10-P4-2
SWDN-P10-P4-M

TECHNICAL DATA

CHARACTERISTICS		
	SWDN-V01-...	SWDN-P10-...
Rated pressure range (set-value)	-1 ÷ 1 bar	0 ÷ 10 bar
Setting pressure range (it can be displayed on the screen)	-1 ÷ 1 bar	-1 ÷ 10 bar
Withstand (Maximum) pressure	3 bar	15 bar
Fluid	Air, non-corrosive gases, incombustible gases	
Set pressure resolution:	0,1	-
kPa	-	0,001
MPa	0,001	0,01
Kgf/cm ²	0,001	0,01
bar	0,01	0,1
Psi	0,1	-
InHg	1	-
mmHg	0,1	-
mmH ₂ O	-	-
Power supply voltage	12-24 VDC ± 10%, ripple (P-P) 10% or less	
Current consumption	≤ 55mA	
PNP switch output	2 outputs with open collector max. load current of 100mA max. power supply voltage of 24VDC residual voltage ≤ 1V (with load current of 80mA)	
Repeatability (switch output)	≤ ± 0,2% F.S. ± 1 digit	
Analog output (where foreseen)	1 - 5V ± 5% F.S.	1 - 5V ± 2,5% F.S. (within the linear range: ≤ ± 1% F.S.)
Hysteresis: Hysteresis mode	Adjustable	
Window comparator mode	Fixed (3 digits)	
Response time	≤ 2,5ms (chattering-proof function: 24ms, 192ms and 768ms)	
Output short circuit protection	YES	
7 segment LED display	3 ½ digit (sampling rate of 5 times/sec)	
Indicator accuracy	≤ ± 2% F.S. ± 1 digit (ambient temperature: 25 ± 3°C)	
Indicator	green LED (OUT1), red LED (OUT2)	
Environment: Protection class	IP40	
Temperature	Operation: 0 ÷ 50°C Storage: -20 ÷ 60°C (without condensation or freezing)	
Relative humidity	Operation/Storage: 35 ÷ 85% (without condensation)	
Withstand (Max.) voltage	1000 VAC in 1 min (between case and lead wire)	
Insulation resistance	50MΩ min. (at 500VDC between case and lead wire)	
Vibration	Total amplitude 1.5 mm 10Hz-55Hz-10Hz scan for 1 minute 2 hours each direction of X, Y and Z	
Shock	980 m/s ² (100G) 3 times each direction of X, Y and Z	
Changes due to temperature	≤ ± 2% F.S. of detected pressure (25°C) within the operating temperature range	
Port size	G1/8 - M5	
Lead wire	Oil-resistance cable (0,15 mm ²)	
Weight	About 67 g for the version with 2-meter lead wire About 35 g for the version with male connector	

Circular M8 4-pole connectors, Female

Protection class: IP65
Materials: PU non shielded cable

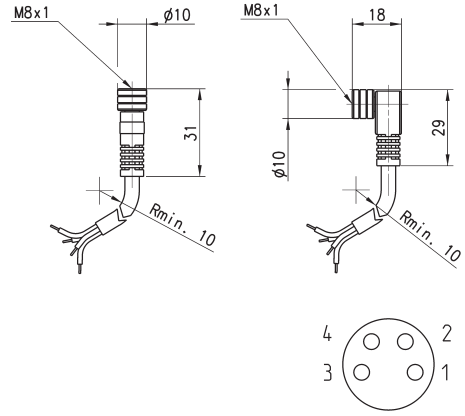

Mod.	Type of connector	Cable length (m)
CS-DF04EG-E200	straight	2
CS-DF04EG-E500	straight	5
CS-DR04EG-E200	90°	2
CS-DR04EG-E500	90°	5

Series SWCN electronic vacuum/pressure switches

New models

With digital display
High precision, easy to use



- » Compact and lightweight
- » Digital indicator: precise electronic insertion with two separated switch outputs
- » Switching point and hysteresis can be programmed with a membrane keypad
- » Upper and lower limit values can be programmed through two PNP switch outputs
- » Analog output 4-20 mA
- » IP65 protection

APPLICATIONS:

- electronic vacuum/pressure switch for safety monitoring, optimization of cycle times or energy saving devices;
- it can be installed directly on the gripping point of a handling system;
- setting of the limit vacuum value and continuous vacuum control;
- perfectly suitable for customer needs.

ELECTRIC CONNECTION:

the device is available with hardwired cable of 2 meters or can be supplied with M8 connector. Accessories and extensions have to be ordered separately. Codes can be found at the end of this section.

GENERAL DATA

Type of pressure/vacuum switch	electronic with polycarbonate housing
Port	with external thread G1/8 and internal thread M5
Display	3 digit display with membrane keypad for the values set up
LED	integrated LED indicators for switching state
Electric connection	with M8 4-pole connector or pre-wired cable of 2 meters

New models

CODING EXAMPLE

SWCN	-	V01	-	P3	-	2
-------------	----------	------------	----------	-----------	----------	----------

SWCN	SERIES
V01	SET PRESSURE RANGE: V01 = from -1 bar to 1 bar P10 = from 0 bar to 10 bar
P3	TYPE OF ELECTRIC CONNECTION: P3 = 2 PNP outputs + 1 analog output 1 - 5 V DC (this version is available with 5-pole cable only) P4 = 2 PNP outputs P6 = 2 PNP outputs + 1 analog output 4-20 mA (this version is available with 5-pole cable only)
2	ELECTRIC CONNECTION: 2 = cable of 2 meters M = M8 4 pin connector

SERIES SWCN ELECTRONIC VACUUM/PRESSURE SWITCHES

Series SWCN Vacuum/Pressure switch with 4-20 mA output

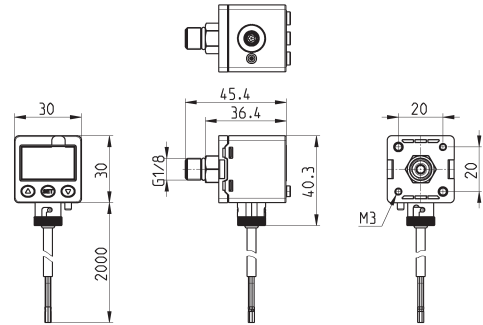

Mod.
SWCN-V01-P6-2
SWCN-P10-P6-2

Series SWCN Vacuum/Pressure switch



1 = brown (+)
2 = white (OUT 2)
3 = blue (-)
4 = black (OUT 1)
Analog output = orange

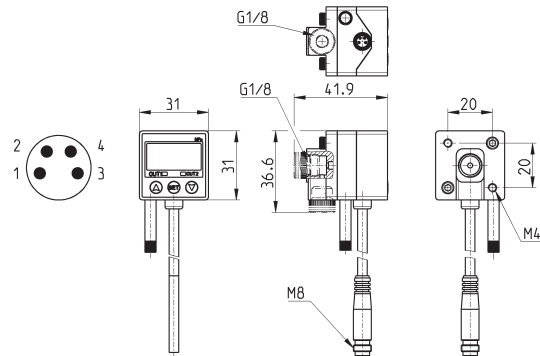

Mod.
SWCN-V01-P3-2
SWCN-V01-P4-2
SWCN-V01-P4-M
SWCN-P10-P3-2
SWCN-P10-P4-2
SWCN-P10-P4-M

TECHNICAL DATA Version P3 and P4

CHARACTERISTICS		
		SWCN-V01-... SWCN-P10-...
Rated pressure range (set-value)		-1 ÷ 1 bar 0 ÷ 10 bar
Setting pressure range (it can be displayed on the screen)		-1 ÷ 1 bar -1 ÷ 10 bar
Withstand (Maximum) pressure		3 bar 15 bar
Fluid		Air, non-corrosive gases, incombustible gases
Set pressure resolution	kPa	0,1 -
	MPa	- 0,001
	Kgf/cm ²	0,001 0,01
	bar	0,001 0,01
	Psi	0,01 0,1
	InHg	0,1 -
	mmHg	1 -
	mmH2O	0,1 -
Power supply voltage		12-24 VDC ± 10%, ripple (P-P) 10% or less
Current consumption		≤ 55mA
PNP switch output		2 outputs with open collector max. load current of 80mA max. power supply voltage of 24VDC residual voltage ≤ 1V (with load current of 80mA)
Repeatability (switch output)		≤ ± 0,2% F.S. ± 1 digit
Analog output (where foreseen)		1 - 5V ± 5% F.S. 1 - 5V ± 2,5% F.S. (within the linearity range: ≤ ± 1% F.S.)
Hysteresis	Hysteresis mode	Adjustable
	Window comparator mode	Fixed (3 digits)
Response time		≤ 2,5ms (chattering-proof function: 24ms, 192ms and 768ms)
Output short circuit protection		YES
7 segment LED display		3 ½ digit (sampling rate of 5 times/sec)
Indicator accuracy		≤ ± 2% F.S. ± 1 digit (ambient temperature: 25 ± 3°C)
Indicator		green LED (OUT1), red LED (OUT2)
Environment	Protection class	IP65
	Temperature	Operation: 0 + 50°C Storage: -20 + 60°C (without condensation or freezing)
	Relative humidity	Operation/Storage: 35 + 85% (without condensation)
	Withstand (Max.) voltage	1000 VAC in 1 min ((between case and lead wire)
	Insulation resistance	50MΩ min. (at 500VDC between case and lead wire)
	Vibration	Total amplitude 1.5 mm 10Hz-55Hz-10Hz scan for 1 minute 2 hours each direction of X, Y and Z
	Shock	980 m/s ² (100G) 3 times each direction of X, Y and Z
	Changes due to temperature	≤ ± 2% F.S. of detected pressure (25°C) within the operating temperature range
	Port size	G1/8 - M5
	Lead wire	Oil-resistance cable(0,15 mm ²)
Weight	About 105 g for the version with 2-meter lead wire About 71 g for the version with male connector	

TECHNICAL DATA Version P6

CHARACTERISTICS			
Fluid	Filtered air, Non-corrosive / Non-flammable gas		
Set pressure resolution	kPa	0,1	-
	MPa	-	0,001
	Kgf/cm ²	0,001	0,01
	bar	0,001	0,01
	Psi	0,01	0,1
	InHg	0,1	-
Power supply voltage	12 ~ 24 V DC ± 10%, ripple (P-P) ≤ 10% (UL class 2)		
Current consumption	≤ 40 mA (with no load)		
Switch output	2 PNP : open collector 2 outputs Max. Load Current : 125 mA Max. Supply Voltage : 24 V DC Residual Voltage : ≤ 1.5 V		
Repeatability	± 0.2 % F.S. ± 1 digit		
Hysteresis	One Point Set Mode Hysteresis mode Window comparator mode	Adjustable	
Response time	≤ 2.5 ms (Chattering-proof function : 25 ms, 100 ms, 250 ms, 500 ms, 1000 ms and 1500 ms selectable)		
Output short circuit protection	YES		
Display	3 ½ digital, 7 segment LCD display (Red / Green / Orange) (Sampling rate : 5 times / sec.)		
Indicator accuracy	± 2 % F.S. ± 1 digit (Ambient temperature : 25 ± 3 °C)		
Switch on Indicator	Orange Indicator 1 : OUT1 & Orange Indicator 2 : OUT2		
Analog Output (Voltage Output)	Output Voltage : 1 ~ 5 V ± 2.5 % F.S. (within rated pressure range) Linearity : ± 1 % F.S. Output Impedance : about 1 kΩ		
Analog Output (Current Output)	Output Current : 4 ~ 20 mA ± 2.5 % F.S. (within rated pressure range) Linearity : ± 1 % F.S. Max. Load Impedance : 250 Ω at power supply of 12 V 600 Ω at power supply of 24 V Min. Load Impedance : 50 Ω		
Environment	Enclosure	IP65	
	Ambient Temp. Range	Operation : 0 ~ 50 °C, Storage : -10 ~ 60 °C (No condensation or freezing)	
	Ambient Humidity Range	Operation / Storage : 35 ~ 85 % RH (No condensation)	
	Withstand Voltage	1000 V AC in 1-min (between case and lead wire)	
	Insulation resistance	≥ 50 MΩ (at 500 V DC, between case and lead wire)	
	Vibration	Total amplitude 1.5 mm or 10 G, 10 Hz ~ 55 Hz ~ 10 Hz scan for 1 minute, 2 hours each direction of X, Y and Z	
	Shock	100 m/s ² (10 G), 3 times each in direction of X, Y and Z	
Temperature Characteristic	≤ ± 2% F.S. of detected pressure (25°C) within the operating temperature range		
Port size	F1 : R1/8", M5 ; F2 : NPT1/8", #10-32 UNF ; F3 : G1/8" (BSPP), M5 F1C : Rc1/8" ; F2C : NPT1/8" ; F3C : G1/8" (BSPP)		
Lead wire	Ø4 Oil-resistance cable (PVC) - 26 AWG (0.15 mm ²) - 5 cores		
Weight (with 2 Meter Lead Wire)	Approx. 86 g (Port F1 ~ F3) ; Approx. 114 g (Port F1C ~ F3C)		

Mounting bracket Mod. SWCN-B



- Supplied with:
- 4 fixing screws M4x5 ISO 724 (fine pitch)
 - 1 fixing bracket for surface mounting (A)
 - 1 fixing bracket for wall mounting (B)

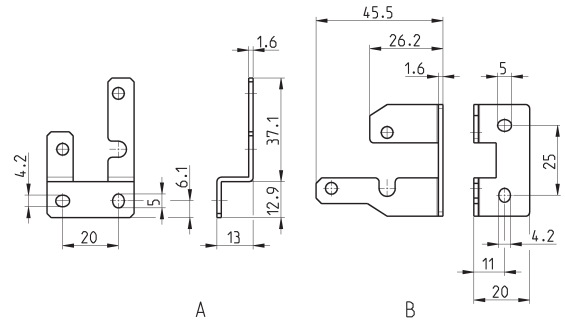

Mod.
SWCN-B

Panel mounting set Mod. SWCN-F

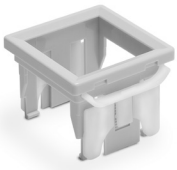

- Supplied with:
- 1 pressure switch holder (A)
 - 2 panel mounting brackets (B)

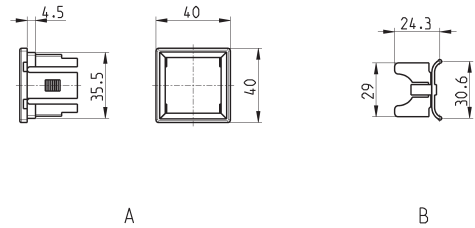

Mod.
SWCN-F

Panel mounting set + transparent cover Mod. SWCN-FP



- Supplied with:
- 1 pressure switch holder (A)
 - 2 panel mounting brackets (B)
 - 1 transparent cover (C)

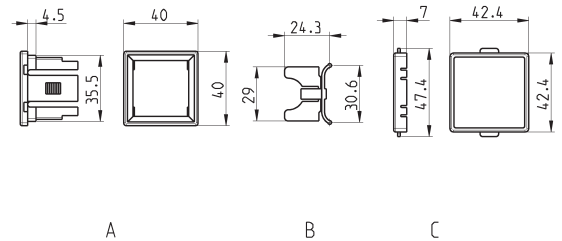

Mod.
SWCN-FP

Circular M8 4-pole connectors, Female



With PU sheathing, non shielded cable.
Protection class: IP65

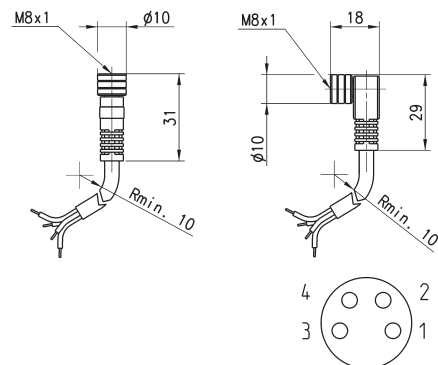

Mod.	Type of connector	Cable length (m)
CS-DF04EG-E200	straight	2
CS-DF04EG-E500	straight	5
CS-DR04EG-E200	right angle (90 degrees)	2
CS-DR04EG-E500	right angle (90 degrees)	5

Example of mounting with bracket Mod. SWCN-B and standard accessories

A: ADDITIONAL POWER SUPPLY

In case of use, please unscrew plug A from one side and mount it on the other one.

B: Use of the AIR FILTER TUBE to reach the IP 65 protection class.

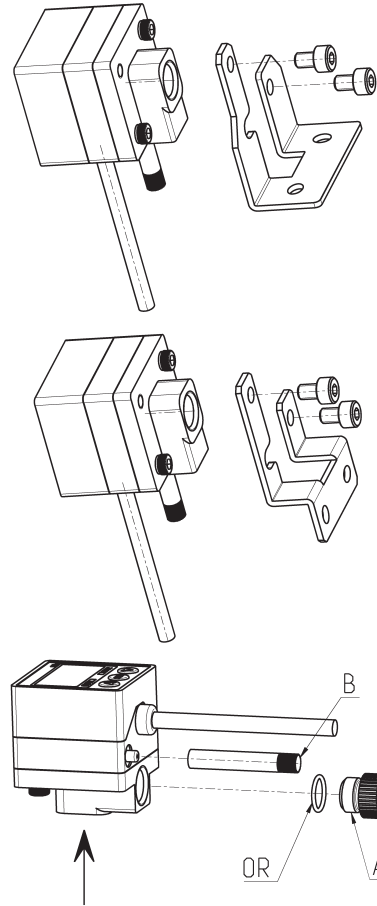

Example of mounting with panel mounting set Mod. SWCN-F

A = PANEL MOUNTING SET MOD. SWCN-F

B = PRESSURE SWITCH MOD. SWCN-...

C = PANEL

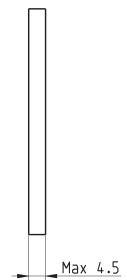
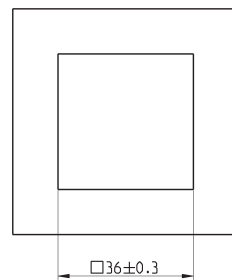
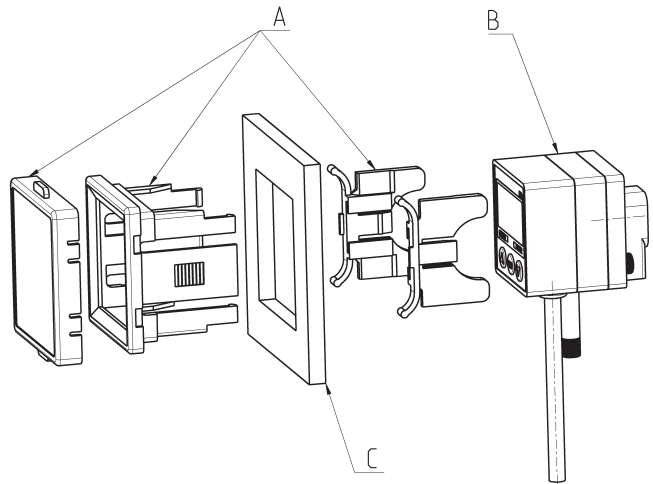

Pressure gauges

New models



- » Radial connection
- » Rear connection
- » Panel mounting

To select the most suitable pressure gauge, the measurement range should be chosen considering the type of application according to the following criteria:

1. Constant pressure or pressure with slow fluctuations should be within 75% of the maximum scale value.
2. Pulsing pressure or rapid fluctuations should be within 65% of the maximum scale value.
3. Pressure peaks should never exceed the maximum scale value.

Miniature pressure gauge

New model

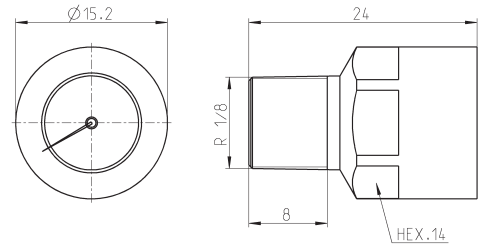

Mod.	Range
M015-P08	0 ÷ 8 bar

Pressure gauges for panel mounting

Precision class CL1,6

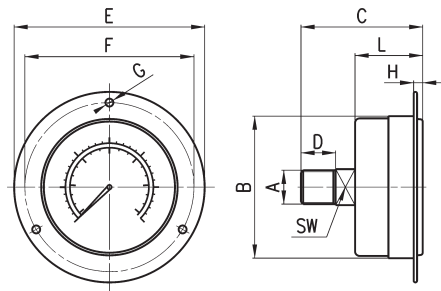

DIMENSIONS											
Mod.	A	B	C	D	E	F	G	H	L	SW	Range
M043-F04	R1/8	∅ 40.5	43	10	61	51	∅ 3.5	4	27	12	0-4 bar
M043-F06	R1/8	∅ 40.5	43	10	61	51	∅ 3.5	4	27	12	0-6 bar
M043-F10	R1/8	∅ 40.5	43	10	61	51	∅ 3.5	4	27	12	0-10 bar
M043-F12	R1/8	∅ 40.5	43	10	61	51	∅ 3.5	4	27	12	0-12 bar
M063-F12	R1/4	∅ 63	54	12	85	75	∅ 3.5	4.5	30.5	14	0-12 bar

Pressure gauges with radial connection

Precision class CL1,6

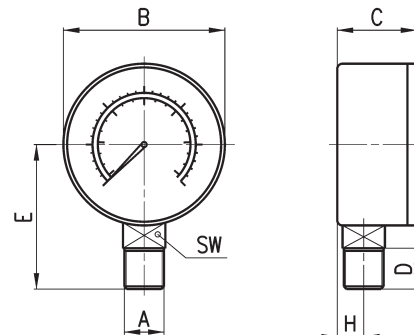

DIMENSIONS									
Mod.	A	B	C	D	E	H	SW	Range	
M043-R06	R1/8	∅ 38.8	24.2	10	35.2	9	12	0-6 bar	
M043-R12	R1/8	∅ 38.8	24.2	10	35.2	9	12	0-12 bar	
M053-R12	R1/8	∅ 48.8	27.5	10	43	10	14	0-12 bar	
M063-R12	R1/4	∅ 63	28.8	12	50	10	14	0-12 bar	

Pressure gauges with rear connection

Precision class CL1,6

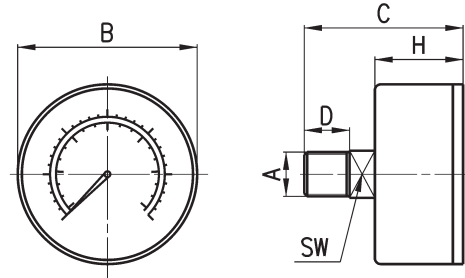

DIMENSIONS							
Mod.	A	B	C	D	H	SW	Range
M043-P02,5	R1/8	∅ 38.8	41	10	25	14	0 ÷ 2.5 bar
M043-P04	R1/8	∅ 38.8	41	10	25	14	0 ÷ 4 bar
M043-P06	R1/8	∅ 38.8	41	10	25	14	0 ÷ 6 bar
M043-P10	R1/8	∅ 38.8	41	10	25	14	0 ÷ 10 bar
M043-P12	R1/8	∅ 38.8	41	10	25	14	0 ÷ 12 bar
M053-P04	R1/8	∅ 50	41.5	10	25	14	0 ÷ 4 bar
M053-P06	R1/8	∅ 50	41.5	10	25	14	0 ÷ 6 bar
M053-P10	R1/8	∅ 50	41.5	10	25	14	0 ÷ 10 bar
M053-P12	R1/8	∅ 50	41.5	10	25	14	0 ÷ 12 bar
M063-P04	R1/4	∅ 63	40.5	12	25	14	0 ÷ 4 bar
M063-P06	R1/4	∅ 63	40.5	12	25	14	0 ÷ 6 bar
M063-P12	R1/4	∅ 63	40.5	12	25	14	0 ÷ 12 bar

Built-in pressure gauge

Precision class CL4,0

Supplied with:
1x pressure gauge
1x seal
2x screws



Fig. 1 = pressure gauge
Fig. 2 = seat

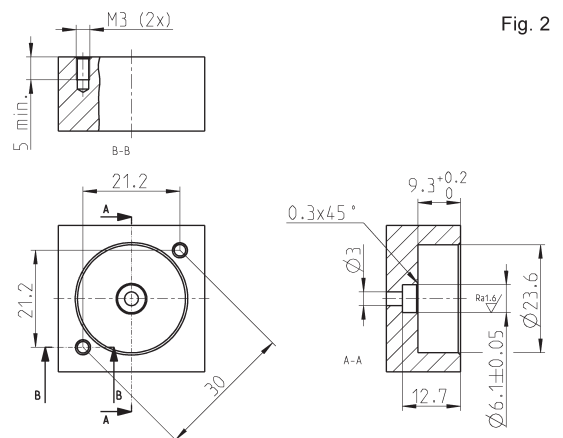
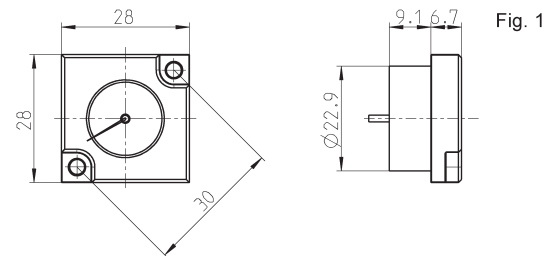

Mod.	Range
MX3-R31/W-P	0 ÷ 6 bar
MX3-R32/W-P	0 ÷ 10 bar
MX3-R30/W-P	0 ÷ 12 bar

Series PG digital pressure gauges

Possibility of a direct mounting with rear or panel connection

SERIES PG DIGITAL PRESSURE GAUGES

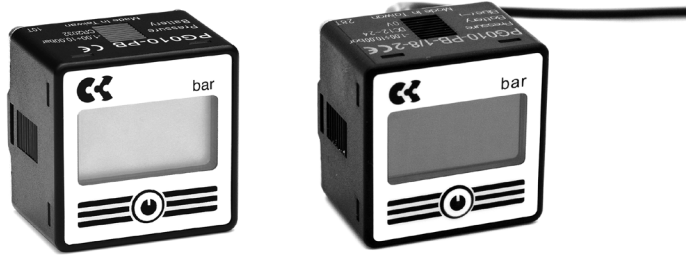

- » Pressure unit on display
- » Battery-powered / with cable
- » Easy and fast read out with digital display
- » 4 user programmable pressure units available
- » Power saving mode
- » Back light
- » Dust-proof and splash-proof (IP65 protection class)

The new Series PG digital pressure gauges meet the need of an even more precise pressure adjustment, above all in proportional control. Thanks to the IP65 protection class these pressure gauges are particularly suitable for applications where the highest environmental protection is required.

TECHNICAL DATA

CHARACTERISTICS		
	Vacuum PG...-VB...	Pressure PG...-PB...
Pressure units	psi, bar, mmHg, kPa programmable by the user	psi, bar, kgf/cm ² , MPa programmable by the user
Rated pressure range	0 ÷ -1 bar	0 ÷ 10 bar
Display pressure range	0.1 ÷ -1 bar	-0.1 ÷ 10 bar
Withstand pressure	3 bar	15 bar
Repeatability	≤ ± 1% F.S. ± 1 digit	≤ ± 0,2% F.S. ± 1 digit
Resolution: kPa	1	-
MPa	-	0.001
kgf/cm ²	0.01	0.01
bar	0.01	0.01
psi	0.1	0.1
Indicator accuracy	≤ ± 2% F.S. ± 1 digit (ambient temperature: 25 ± 3°C)	
Medium	Filtered air, incombustible and non-corrosive gases	
Back light	Yes	
Sample rate	2 Hz (2 times/second)	
LCD display	3 ½ digit, 7 segment	
Environment: Protection class	IP65 (an air tube must be installed to maintain this grade)	
Temperature	Operation: 0 ÷ 50°C Storage: -10 ÷ 60°C (no condensation or freezing)	
Relative humidity	Operation/storage: 35 ÷ 85% RH (no condensation)	
Vibrations	Total amplitude 1.5mm or 10G 10Hz-55Hz-10Hz scan for 1 minute 2 hours for each direction of X, Y and Z	
Shock	100 m/s ² (10G) 3 times for each direction of X, Y and Z	
Changes due to temperature	≤ ± 2% F.S. of detected pressure (25°C) within the operating temperature range	
Pneumatic connections ports	G1/4 - M5 or G1/8 - M5	
FOR BATTERY-POWERED PRESSURE GAUGES ONLY		
Battery: Type	CR 2032 lithium	
Life	1 year (5 times/day)	
Low-power indicator	Yes	
Replacement	Yes	
Turn-on interval	Display turns off after 60 seconds	
FOR PRESSURE GAUGES WITH POWER SUPPLY CABLE ONLY		
Supply voltage	from 12 to 28 V DC ± 10% Ripple	
Power consumption	10 mA	
Maximum voltage	1000V AC in 1-min (between the casing and the cables)	
Isolation resistance	50 Mohm min (at 500 V DC, between the casing and the cables)	
Electrical connection: for pressure gauges PG...-2	Unshielded 2-pole cable, length 2 m	
for pressure gauges PG...-M	Connection with M8 4-pole connector	

CODING EXAMPLE

PG	010	-	P	B	-	1/8	-	2
PG	SERIES							
010	BOTTOM SCALE: 010 = 10 bar 001 = -1 bar							
P	PRESSURE RANGE: P = pressure V = vacuum							
B	LIGHTING: B = back light							
1/8	PNEUMATIC CONNECTIONS: 1/8 = G 1/8 BSPP; M5 1/4 = G 1/4 BSPP; M5 (for battery-powered version only)							
2	ELECTRICAL CONNECTION (for version with cable only): 2 = with unshielded 2-pole cable of 2 m M = with cable of 150 mm and M8 4-pole connector							

SERIES PG DIGITAL PRESSURE GAUGES

Series PG digital pressure gauges - battery-powered

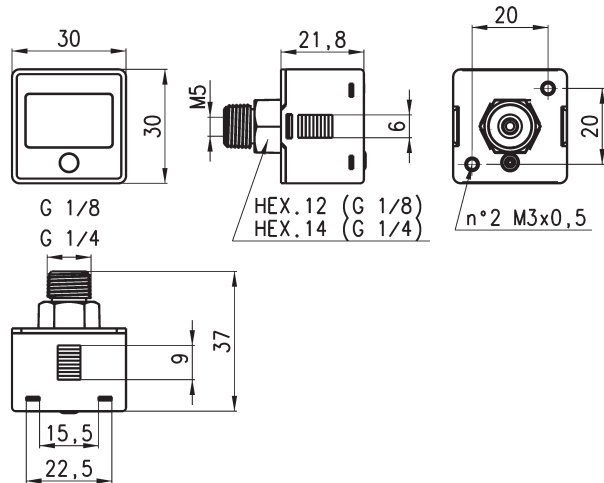

Mod.
PG010-PB-1/8
PG001-VB-1/8
PG010-PB-1/4
PG001-VB-1/4

Series PG digital pressure gauges - with cable

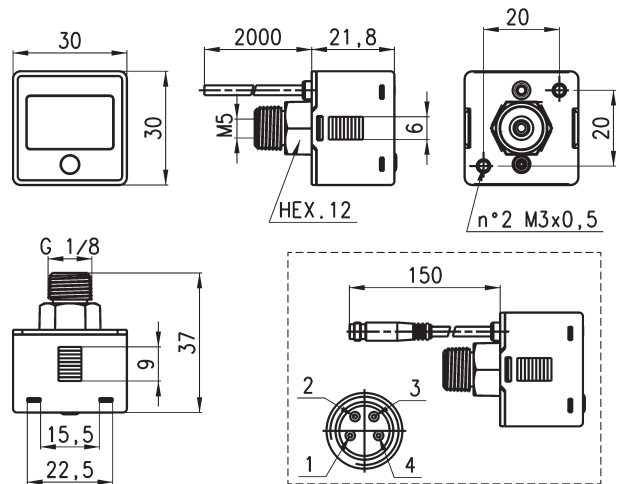

Mod.

PG010-PB-1/8-2

PG001-VB-1/8-2

PG010-PB-1/8-M

PG001-VB-1/8-M

Mounting brackets Mod. PG-B



Supplied with:
 1x bracket type A
 1x bracket type B
 2x screws M3x6

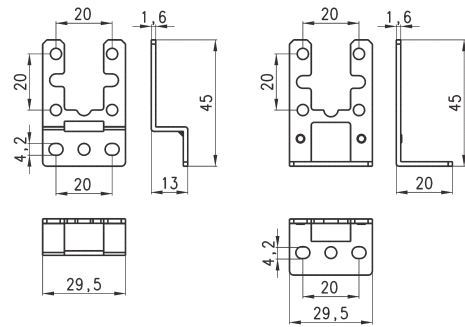

Mod.

PG-B

Panel mounting adapter Mod. PG-F

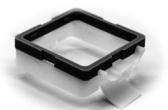

Supplied with:
 1x adapter type A
 1x adapter type B

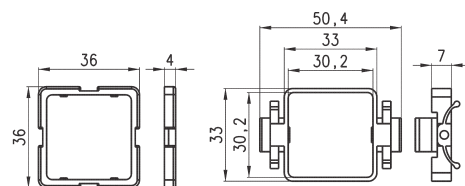

Mod.

PG-F

Condensate drains Filtering elements

Semi-automatic manual drain; Automatic drain;
Depressurisation drain; Depressurisation drain, protected
Ports: 1/8 (without drain)

FUNCTIONING CONDENSATE DRAINS AND FILTERING ELEMENTS



The filters are used to remove impurities in the compressed air, which must then be removed from the pneumatic circuit. The filters can be equipped with different types of drainings of condensate, both automatic and manual. The correct combination and the functioning is reported in the table and in the descriptions on the following pages.

Different requirements of the air quality determine the use of different types of filtering elements, which retain the impurities during their working, thus clogging and reducing the amount of air in the passage. For this reason it is suggested to replace them once a year at least.

COMBINATION OF FILTERS / BOWL WITH DRAIN / FILTERING ELEMENT

* for Series MD the "bowl with drain" is supplied complete with the filtering element

Mod. filter	bowl with semi-automatic manual drain	bowl with automatic drain	bowl with depressurization drain	bowl with depressurization drain, protected	bowl without drain (1/8 port)	closed bowl	filtering element 25 μ	filtering element 5 μ	filtering element 1 μ	filtering element 0.01 μ	activated carbon
N10...-F	N1-F71				N1-F71-1/8		C104-F20/3	C104-F21/3			
N10...-D	N1-F71				N1-F71-1/8		C104-F20/3	C104-F21/3			
N10...-FB	N1-F71				N1-F71-1/8					MX1-F10	
N20...-F	N2-F71		N2-F71/2	N2-F71/1	N2-F71-1/8		C104-F20/3	C104-F21/3			
N20...-D	N2-F71		N2-F71/2	N2-F71/1	N2-F71-1/8		C104-F20/3	C104-F21/3			
N20...-FB	N2-F71		N2-F71/2	N2-F71/1	N2-F71-1/8					MX1-F10	
N20...-FCA						N2-L71					MX1-F11
MC104-F	MC1-F71		MC1-F71/2	MC1-F71/1	MC1-F71-1/8		C104-F20/3	C104-F21/3			
MC104-D	MC1-F71		MC1-F71/2	MC1-F71/1	MC1-F71-1/8		C104-F20/3	C104-F21/3			
MC104-FB	MC1-F71		MC1-F71/2	MC1-F71/1	MC1-F71-1/8					MX1-F10	
MC104-FCA						MC1-L71					MX1-F11
MC202-F	MC2-F71	MC2-F71/3		MC2-F71/1	MC2-F71-1/8		C238-F11/3	C238-F12/3			
MC202-D	MC2-F71	MC2-F71/3		MC2-F71/1	MC2-F71-1/8		C238-F11/3	C238-F12/3			
MC202-FB	MC2-F71	MC2-F71/3		MC2-F71/1	MC2-F71-1/8					MX2-F10	
MC202-FCA						MC2-L71					MX2-F11
MC238-F	MC2-F71	MC2-F71/3		MC2-F71/1	MC2-F71-1/8		C238-F11/3	C238-F12/3			
MC238-D	MC2-F71	MC2-F71/3		MC2-F71/1	MC2-F71-1/8		C238-F11/3	C238-F12/3			
MC238-FB	MC2-F71	MC2-F71/3		MC2-F71/1	MC2-F71-1/8					MX2-F10	
MC238-FCA						MC2-L71					MX2-F11
MX2...-F	MX2-F2-P	MX2-F2/1-P		MX2-F2/3-P	MX2-F2/2-P		C238-F11/3	C238-F12/3			
MX2...FR	MX2-F2-P	MX2-F2/1-P		MX2-F2/3-P	MX2-F2/2-P		C238-F11/3	C238-F12/3			
MX2...-FC	MX2-F2-P	MX2-F2/1-P		MX2-F2/3-P	MX2-F2/2-P				MX2-F9	MX2-F10	
MX2...-FCA						MX2-L2-P					MX2-F11
MX3...-F	MX3-F2-P	MX3-F2/1-P		MX3-F2/3-P	MX3-F2/2-P		MX3-F7	MX3-F8			
MX3...-FR	MX3-F2-P	MX3-F2/1-P		MX3-F2/3-P	MX3-F2/2-P		MX3-F7	MX3-F8			
MX3...-FC	MX3-F2-P	MX3-F2/1-P		MX3-F2/3-P	MX3-F2/2-P				MX3-F9	MX3-F10	
MX3...-FCA						MX3-L2-P					MX3-F11
MD1-F0..*	MD1-FSP01			MD1-FSP03	MD1-FSP02		C104-F20/3				
MD1-F1..*	MD1-FSP04			MD1-FSP06	MD1-FSP05			C104-F21/3			
MD1-FR0..*	MD1-FSP01			MD1-FSP03	MD1-FSP02		C104-F20/3				
MD1-FR1..*	MD1-FSP04			MD1-FSP06	MD1-FSP05			C104-F21/3			
MD1-FC0..*	MD1-FCSP01			MD1-FCSP03	MD1-FCSP02					MD1-F10	
MD1-FC1..*	MD1-FCSP04			MD1-FCSP06	MD1-FCSP05				MD1-F9		
MD1-FCA..*						MD1-FCASP01					MD1-F11

Semi-automatic manual drain (Type 0 and 1)

Functioning: with the operator mechanism turned clockwise, each time the pressure falls below 0.3 bar, the draining of condensate will be released; when resetting the pressure, the drain will close again. The release can also be carried out manually; when the bowl is pressurised, the operator mechanism is pushed upwards.

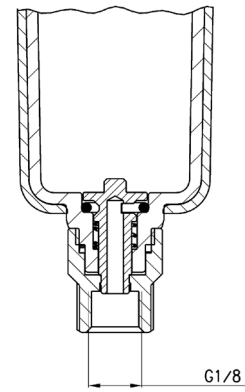

To avoid the discharge of condensate, the drain. the operator mechanism should be turned clockwise to completely close

Automatic drain (Type 3)

Functioning: the presence of liquid inside the bowl raises the float, thus opening the exhaust valve.

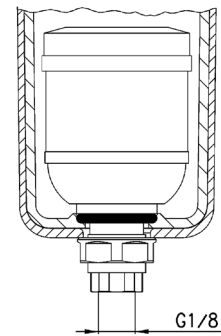

Depressurisation drain (Type 4)

Functioning: each time air is required from the inlet, a slight difference of pressure is created between the upper part and lower part of the drain that rises, thus opening the exhaust valve.

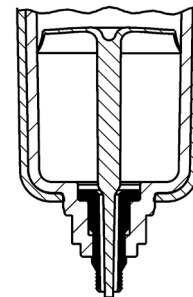

Depressurisation drain, protected (Type 5)

Solution similar to the Type 4 but requiring a $\Delta P = 1$ bar.
 Functioning: this version has a filtering element which prevents any impurities from clogging the exhaust hole.

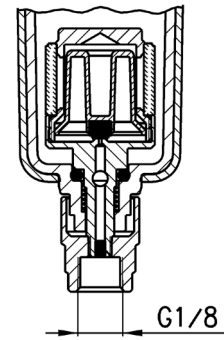

Bowl without drain (Type 8)

The solution with port G1/8 is used to assemble the items to the bowl which is realized with a through hole of $\varnothing 3$ mm and a threaded port G1/8.

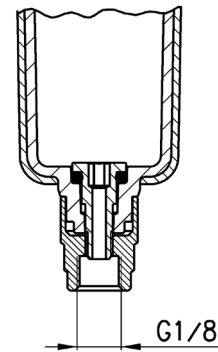

Closed bowl

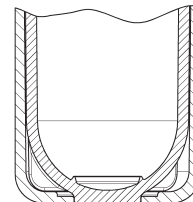

Contacts

Camozzi Automation S.p.A.

Società Unipersonale
Via Eritrea, 20/I
25126 Brescia
Italy
Tel. +39 030 37921
info@camozzi.com



Automation

